

# TELEVISION

News

HUGO GERNSBACK Editor

### FEATURES:

- TELEVISION—TODAY AND TOMORROW  
BY DAVID SARNOFF
- THE SANABRIA GIANT  
TELEVISION SCREEN
- SYNCHRONIZING WITH A  
HOME-MADE MOTOR
- AN EXPERIMENTAL KERR CELL
- BUILDING A SYNCHRONOUS  
MOTOR
- ENZO'S NEW TELEVISION  
RECEIVER



October

50¢

Jenkins Televises With New Lighting System

# Baird TELEVISION KITS

# Build your own Baird at home!

—get world-wide shortwave reception!  
—see clear, distortionless Television Pictures!

*Never before a set so practical—simple to operate  
—easy to assemble—at anywhere near these prices!*

Build your own Receivers from these Baird-built kits—quickly and at lowest cost! Enjoy the thrills of tuning in shortwave stations from all over the world! See and enjoy pictures and programs from your favorite Television stations! Amaze your friends with this newest, most thrilling form of radio entertainment! Baird-built kits are complete. You can quickly assemble them—complete your Television Receiver in an hour—your Shortwave Set in a few hours. Charts and wiring diagrams furnished with each kit.

### Features of No. 25 BAIRD UNIVERSAL SHORTWAVE KIT

Ear phone jack; phonograph pick-up; all aluminum chassis; coils and screen grid tubes individually shielded; carefully shielded variable condensers; two shielded stages of screen grid radio frequency; shielded screen grid detector; uses famous OCTOCOILS; highest quality resistance coupled amplification; 245 power tube; wave length range 15 to 520 meters; single dial control; operates dynamic or magnetic speaker. Quality equal to any high class broadcast receiver!

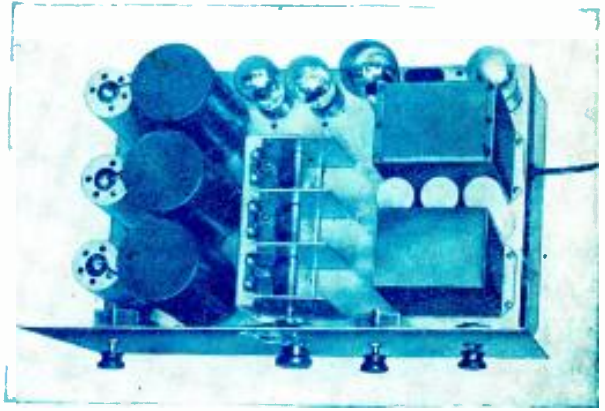

*We have no connection with any company using a similar name.*

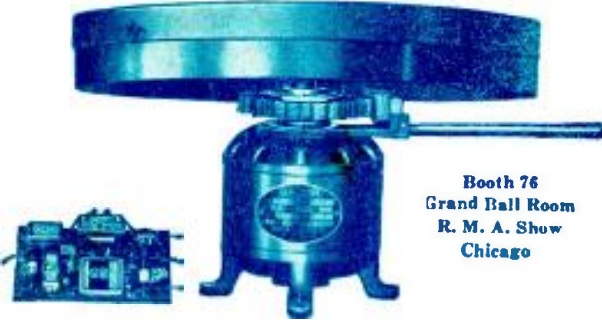

Booth 76  
Grand Ball Room  
R. M. A. Show  
Chicago

### No. 26 BAIRD TELEVISION KIT

Amazingly simple in construction. Can be put together in an hour. You can make it work and actually SEE TELEVISION PICTURES in a few moments! It is the only Television Kit offered which has Horizontal scanning equipment (the only satisfactory, distortionless method of Television reception) and automatic synchronization of pictures—no fussing, no struggling to keep your picture in frame. Baird-built kits are complete in every detail—there is nothing more to buy—nothing to detract from your immediate enjoyment of Television as soon as you have assembled your set. Write for booklet and information—today.

**Baird Sets May Also Be Purchased Fully Wired.**

## SHORTWAVE & TELEVISION CORPORATION

70 Brookline Avenue Dept T-1 Boston, Mass., U.S.A.

*Owners and Operators of Stations W1XAV and W1XAU at Boston*

**Send for this booklet today !!**



SHORTWAVE & TELEVISION CORPORATION  
70 Brookline Avenue, Boston, Mass.

Dept. T-1

A deposit of \$5.00 with each unit ordered—balance C. O. D.

- Enclosed find 25c for booklet, "Romance and Reality of Television," including diagrams for 1, 2 and 3-tube shortwave tuners, also list of shortwave stations of the world. Please send me the following at special advertiser's prices listed below:
  - No. 25 Complete Short Wave Kit, wave length range 15 to 550 meters, including 2 sets of OCTOCOILS, blueprint and construction manual (less tubes and cabinet) \$56.25
  - No. 26 Television Kit complete with Lens, Television Lamp, Synchronizing Amplifier, Synchronizing Motor and Cabinet. Check 45-18-60 line..... 60.00
  - No. 35 Short Wave Receiver, complete in metal cabinet, including 2 sets of OCTOCOILS (less tubes)..... 82.75
  - No. 36 Television Receiver, completely assembled in cabinet. Ready to operate in conjunction with a No. 25 or No. 35 Short Wave Receiver..... 75.00
  - OCTOCOILS, set of four coils, wave length range 15 to 200 meters..... 3.75
- Diagram of 3-tube Tuner sent free on request with stamped self-addressed envelope.

Name ..... Address.....  
City..... State.....

TELEVISION NEWS—Bi-monthly. Entered as second class matter February 16, 1931, at the post office at Mount Morris, Illinois, under the act of March 3, 1879. Trademarks and copyrights by permission of H. Gernsback, 98 Park Place, N. Y. C. Text and illustrations of this magazine are copyrighted and must not be reproduced without permission.



# YOU'RE WANTED *for a* Big Pay Radio Job

## I'll Train You at Home in Your Spare Time for RADIO · TELEVISION · TALKING MOVIES

J. E. Smith, President, National Radio Institute, the man who has directed the Home-Study training of more men for the Radio Industry than any other man in America.



### Set Servicing

Spare-time set servicing is paying N. R. I. men \$200 to \$1,000 a year. Full-time men are making as much as \$65, \$75 and \$100 a week.

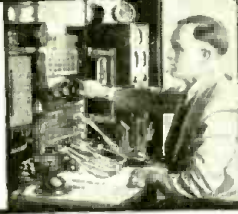

### Broadcasting Stations

Need trained men continually for jobs paying \$1,200 to \$5,000 a year.



### Ship Operating

Radio operators on ships see the world free and get good pay plus expenses.

### Aircraft Radio

Aviation is needing more and more trained Radio men. Operators employed through Civil Service Commission earn \$1,620 to \$2,800 a year.



### Talking Movies

An invention made possible by Radio. Offers many fine jobs to well-trained Radio men, paying \$75 to \$200 a week.



### Television

The coming field of many great opportunities is covered by my course.



**I**F YOU are earning a penny less than \$50 a week, send for my book of information on the opportunities in Radio. It is free. Clip the coupon NOW. Why be satisfied with \$25, \$30 or \$40 a week for longer than the short time it takes to get ready for Radio?

### Radio's Growth Opening Hundreds of \$50, \$75, \$100 a Week Jobs Every Year

In about ten years Radio has grown from a \$2,000,000 to a \$1,000,000,000 industry. Over 800,000 jobs have been created. Hundreds more are being opened every year by its continued growth. Men and young men with the right training—the kind of training I give you—are stepping into Radio at two and three times their former salaries. J. A. Vaughn, 4075 S. Grand Boulevard, St. Louis, Mo., writes: "Before I entered Radio I was making \$35 a week. Last week I earned \$110 selling and servicing sets. I owe my success to N. R. I."

### You Have Many Jobs To Choose From

Broadcasting stations use engineers, operators, station managers and pay \$1,200 to \$5,000 a year. Manufacturers continually need testers, inspectors, foremen, engineers, service men, buyers, for jobs paying up to \$7,500 a year. Shipping companies use hundreds of Radio operators, give them world-wide travel with board and lodging free and a salary of \$80 to \$150 a month. Dealers and jobbers employ service men, salesmen, buyers, managers, and pay \$30 to \$100 a week. There are many other opportunities too.

### So Many Opportunities Many N. R. I. Men Make \$200 to \$1000 While Learning

The day you enroll with me I'll show you how to do 28 jobs, common in most every neighborhood, for spare-time money. Throughout your course I send you information on servicing popular makes of sets; I give you the plans and ideas that are making \$200 to \$1,000 for hundreds of N. R. I. students in their spare time while studying. My course is famous as the one that pays for itself. G. W. Page, 2210 Eighth Ave., S., Nashville, Tenn., writes: "I picked up \$935 in my spare time while taking your course."

### I give you 8 Outfits of Radio Parts for Practical Home Experiments

You can build over 100 circuits with these outfits. You build and experiment with the circuits used in Crosley, Atwater Kent, Eveready, Majestic, Zenith, and other popular sets. You learn how these sets work, why they work, how to make them work. This makes learning at home easy, fascinating, practical.

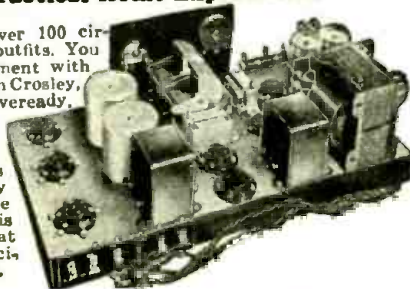

Special training in Talking Movies, Television and home Television experiments, Radio's use in Aviation, Servicing and Merchandising Sets, Broadcasting, Commercial and Ship Operating are included. I am so sure that I can train you satisfactorily that I will agree in writing to refund every penny of your tuition if you are not satisfied with my Lessons and Instruction Service upon completing.

### Talking Movies, Television and Aircraft Radio are Also Included

Special training in Talking Movies, Television and home Television experiments, Radio's use in Aviation, Servicing and Merchandising Sets, Broadcasting, Commercial and Ship Operating are included. I am so sure that I can train you satisfactorily that I will agree in writing to refund every penny of your tuition if you are not satisfied with my Lessons and Instruction Service upon completing.

### 64-page Book of Information Free

Get your copy today. It tells you where Radio's good jobs are, what they pay, tells you about my course, what others who have taken it are doing and making. Find out what Radio offers you, without the slightest obligation. ACT NOW!

J. E. SMITH, President  
National Radio Institute  
Dept. 1JC4  
Washington, D. C.



**THIS COUPON IS GOOD for**  
**One FREE COPY OF** *mail it now*  
**MY BOOK**

J. E. SMITH, President  
National Radio Institute, Dept. 1JC4  
Washington, D. C.

Dear Mr. Smith: Send me your free 64-page book, "Rich Rewards in Radio." I understand this does not obligate me and that no salesman will call.

Name.....

Address.....

City..... State.....

Please mention TELEVISION NEWS when writing to advertisers

HUGO GERNSBACK, Editor

H. WINFIELD SECOR, Managing Editor

# CONTENTS

SEPT. - OCT., 1931, ISSUE

*In This Issue—Prominent Television Authorities*

**Sarnoff — Replugle — Dr. Ives — Cisin — Fitch — Nason — Du Mont**

**FEATURES:**

Editorial .....	245
How Jenkins Televises With New Lighting Scheme, by D. E. Replugle.....	246
In the Television Eye.....	249
Television—Today and Tomorrow, by David Sarnoff, President of the Radio Corp. of America.....	250
What Television Inventors Are Doing.....	252
Columbia Is Telecasting!.....	253
How I Produce 6½ Foot Images, by Ulysses A. Sanabria, As Told to H. Winfield Secor.....	254
Some Interesting Optical Features in Two-Way Television, by Dr. Herbert E. Ives, of the Bell Telephone Labs. ....	257
How We Staged the World's First Television Plays, by William J. Toneski.....	260
The "Find-All" Television Receiver, by H. G. Cisin, M.E. ....	264
How We Received W3XK Images in Kansas. by C. Bradner Brown.....	268
New Helical Mirror for Television Scanning.....	270
Synchronous Images With a Home-Built Motor, by Clyde J. Fitch.....	272
The New Baird Television and S-W Receiver, by Joseph Calcaterra .....	276
Thrill of a Televised Derby.....	281
A Short Course in Television, Lesson 4—Elementary Television Optics, by C. H. W. Nason... ..	282
The Practical Operation of a Complete Television System, by Allen B. Du Mont.....	284
How to Make a Synchronous Motor, by R. Stair and S. R. Winters.....	294
How Shall I Synchronize Better? by Rudolf Schadow (Berlin) .....	298

**TELEVISION RECEIVERS:**

The "See-All" Television Kit.....	256
The "Find-All" Television Receiver.....	264
Detection in Television Receivers.....	267
An "Impedance-Coupled" Television Receiver....	268
How to Build a Synchronizing Motors (Phonic Wheels) .....	272
Belt Scanners—How They Work.....	275
The New Baird Television and S-W Receiver.....	276
A Crater Tube Scanner for Large Images.....	287
How to Build a Synchronous Motor for Driving Scanning Disc .....	294
How Shall I Synchronize Better?.....	298
A Receiver for Television Experimenters On Short Waves .....	301
The Barthélemy System.....	302

**TRANSMITTERS:**

The newest Jenkins Pickup Camera and Illumination Device .....	246
Columbia Broadcasting System's New Television Transmitter Starts Telecasting.....	253
Sanabria Television Pick-up and Amplifier.....	254
Latest Developments in the Bell Laboratory Television Pickup. ....	257

**MISCELLANEOUS:**

Belt-Scanners .....	275
All About the Kerr Cell.....	280
Novel Photo Recorder for Television.....	290
Digest of Television Patents.....	291
Seeing Is Believing.....	293
An Early Television and Picture Transmission Proposal .....	297
Television Question Box.....	304
The Importance of Resistors in Television, by H. G. Cisin, M.E.....	306
Television Time-Table .....	318

**OUR COVER** — Illustrates the Very Newest Method Used in the Jenkins Studio for Illuminating the Artists, Also Direct Pickup Camera. See Page..... 246

TELEVISION NEWS—Bi-monthly. Entered as second class matter Feb. 16, 1931, at the post office at Mount Morris, Illinois, under the act of March 3, 1879. Trademarks and copyrights by permission of H. Gernsback, 98 Park Place, N. Y. C. Text and illustrations of this magazine are copyright and must not be reproduced without permission. TELEVISION NEWS is published on the 15th of every other month. Six numbers per year. Subscription price is \$3.00 a year in the United States and possessions. Canada and foreign countries, \$3.50

a year. Single copies 50c. Address all contributions for publication to Editor, TELEVISION NEWS, 96-98 Park Place, New York, N. Y. Publishers are not responsible for lost manuscripts. Contributions cannot be returned unless authors remit full postage. TELEVISION NEWS is for sale at all principal newsstands in the United States and Canada. European agents: Brentano's, London and Paris. Printed in U. S. A. Make all subscription checks payable to Popular Book Corporation.

COPYRIGHT, 1931, BY H. GERNSBACK

Published by **POPULAR BOOK CORPORATION**

H. GERNSBACK, President - H. W. SECOR, Vice-President

Publication Office, 404 N. Wesley Avenue, Mount Morris, Ill.  
Editorial and General Offices, 96-98 Park Place, New York, N. Y.

HUGO GERNSBACK, EDITOR  
H. WINFIELD SECOR, MANAGING EDITOR

## TELEVISION STEPS OUT

By HUGO GERNSBACK

**A**T THE present time there appears to be a tremendous activity in television in every radio laboratory, all over the country.

There is not a radio set manufacturer today who has not his technical staff either investigating television or is not pioneering into uncharted waters himself. This is not an over-statement of the conditions, because it is the first time to my knowledge that the interest has been so intense as it is now.

New developments in television are coming along almost every day; and the only comparison I can make is with that boom the radio industry experienced in its broadcasting infancy during 1920-1921.

There has been a furious activity in new television company incorporations lately, and anyone picking up a newspaper will find this statement confirmed. It may well be that television will be one of the factors that will help lift the country out of the present depression.

The Department of Commerce, through the Radio Commission, has been overwhelmed with television applications during the past few months, and new applications are pouring in almost daily.

The month of July saw the opening of the Columbia Network's television station in New York and, though the sound went out over the entire network, on the opening night, the sight impulses at this time of writing are disseminated only by a single station in New York. Sound is broadcast on 49.02 meters from W2XE.

It may be said with little fear of contradiction that, if one of the important radio broadcast chains is now actually broadcasting television daily, the day is not far off when every home will have a television receiver. Of course, as I have said before, this day has not yet arrived, and possibly it will not for another year. As yet, television belongs rightfully to the experimenter and the dabbler; but, once we have several hundred thousands of this class interested, the public, as usual, will not be lagging far behind.

Important developments are now in the offing; chiefly our long-predicted cathode tube, of which I have been speaking for these last fifteen years. This is now about ready to emerge from the laboratory, and it is quite certain that, before the end of this year, commercial cathode tube television receivers will be on the market.

The disc and motor will, of course, prevail for some time to come; because it seems likely that the cathode tube will not be perfected very soon and will, probably, be as expensive or more expensive than the disc and motor combination today. Evidently the manufacturers of television equipment are convinced of this; because an increasing number of them are now putting out discs and motors, and the next few months will probably see an avalanche of these. The discs are becoming smaller, as are the motors; and we will very shortly have many low-priced kits for experimenters and fans to experiment with to their heart's content.

In the meanwhile, new developments are coming hard and fast, with the broadcast transmitters; and it will not be long before all broadcast chains will disseminate both *sound and sight*.

The development which seems most logical, at this time, is that the smaller stations participating in the network will broadcast television on extremely short waves—of the type known as *quasi-optical* waves. The advantage here is that

there can be several thousand television transmitters all over the country, without mutual interference, because the transmission only reaches a few miles and does not pass beyond the horizon.

It has also been found that a television antenna at a high elevation is much more efficient and gives better images than a low antenna. For that reason, the National Broadcasting Corporation has already rented space in the Empire State Building; where it will have an antenna some 1,200 feet above the ground, for broadcasting television exclusively. With a bit of power behind such broadcasts, it will be possible to get most excellent images within a radius of some twenty to thirty miles; all depending upon the height of the transmitting antenna.

Of course, we will have with us still the ancient television problem—that we require two radio sets; one to receive sound and the other to receive sight. But the day is not far off perhaps, when all broadcasting will be done on the so-called micro-waves which I mentioned before. It seems likely that with these waves a simultaneous broadcast of both sight and sound on the same "carrier frequency" will be achieved at some not too future date.

I have for many years maintained that, ultimately, broadcasting will be done on short waves, and I still am of that opinion. With television, it seems at the present time impossible to broadcast except on short waves. It follows logically that, if the listener must buy two sets, one for the short waves and one for the higher waves, our technicians will sooner or later see the light and relegate the entire broadcast art into the short-wave spectrum; where we have more elbow-room and where we will do away with practically all interference, heterodyne whistles, and the like.

Of course, such developments are still in the future, and it is well that changes of this class should be gradual; because, if they were not, the entire radio industry might well be thrown into confusion. In this respect however, the radio industry is not different from the automobile industry which started out with open cars and solid rubber tires. Later on, by gradual changes, the closed car was introduced, with the small pneumatic tires; and still later, the balloon tire came along. That meant, of course, the scrapping of *all* the old cars; but the point is that the change was done gradually, without disturbance to the industry.

It will be so with radio and, if our technicians are becoming convinced that broadcasting of the future, mainly on account of television, can be done only on quasi-optical waves, then our broadcasters and our set manufacturers will follow suit and there will be a gradual change and exodus down to the short waves.

This change will solve a host of problems which seem, in view of the television element today, so baffling and almost insurmountable to the technician. To mention only one great advantage, there is the practically total elimination of static. At the present time atmospheric disturbances affect many programs and, even on the present short waves, television images are badly blurred by static. With the quasi-optical waves (of say 3 to 4 inches length), static is practically unknown and, if we couple this advantage to the almost total elimination of station interference, it would seem that no effort will be too great for the industry, to switch from the higher to these extra-low waves.

TELEVISION NEWS IS PUBLISHED ON THE 15th OF EVERY OTHER MONTH

THE NEXT ISSUE COMES OUT OCTOBER 15TH

# JENKINS

By D. E. REPLOGLE\*

*Specially Written for TELEVISION NEWS*

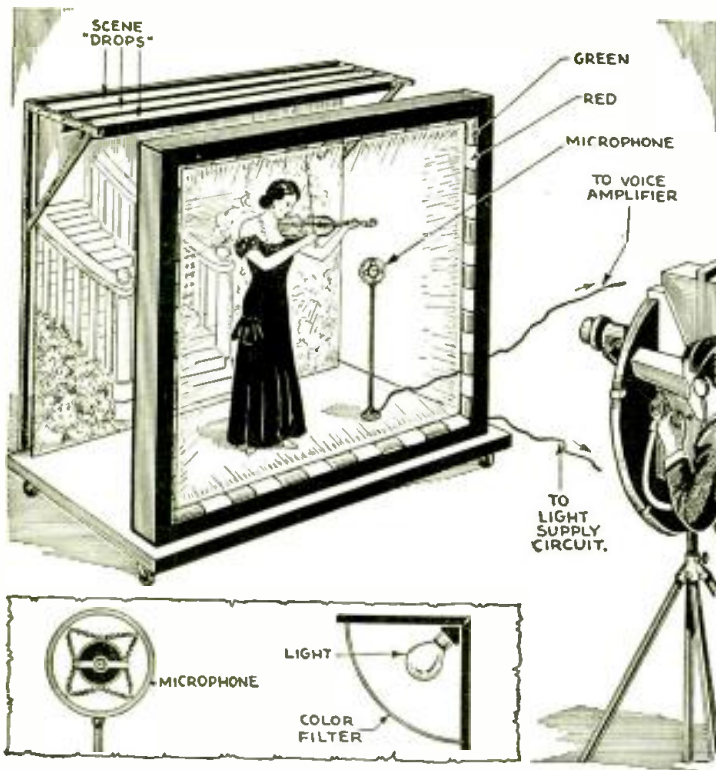

The newest Jenkins "stage lighting" scheme for use in the television studio, the artists being illuminated by lights placed behind red and green color filters arranged around the frame as shown.

How best to illuminate the person who stands or sits before the television pickup, has been one of the toughest problems which television engineers had to solve. Mr. Replogle gives us some interesting fresh angles which show how the Jenkins experts have solved the problem, without having to use the old-style highly concentrated banks of lights, which are very annoying to the artist. The value of colored lights is also explained.

THE flying-spot type of pickup, which is used by all present television broadcast stations, has one major disadvantage along with several minor disadvantages. The major one is lack of flexibility, which handicaps the showman in making television presentations, along with the necessity that the studio should be darkened, or at least illuminated with special colored lights.

The studio of the future will undoubtedly present a different picture from the present fixed-apparatus type. In this future studio, one will find several pieces of apparatus which, in appearance and operation, will closely resemble the conventional camera, found in today's motion-picture studios. The scenes to be televised will be staged on special stages or sets, before each of which will be a cameraman with his camera. Off from the studio will be a make-up room, with the make-up attendants, a costumer's room and a property room. Curtains at the rear of the sets will be used for scenery; and back in the control room will be a highly-paid specialist, who will "mix" the scenes coming from the various sets, and put on the air, in proper continuity, the story as the author meant it to be.

All the continuity ideas of the picture will rest on his shoulders. On his skill will depend the sight and the sound emphasis which must be placed on each part of the plot. Here the pictures coming from two or more sets will be "mixed" and sent out to

the radio transmitter at the proper time. This specialist will correspond to the present "film editor," who cuts out the unwanted parts of the scenes that have been "shot," and pieces together the completed picture.

When such studios are available, together with proper receiving equipment for the home end (which is well on the road to production), we can truly say, "Television is here with genuine entertainment value."

### Direct Pickup Camera, the Latest Step Ahead

The most recent step forward towards the aforementioned ideal is in the development of the direct pickup

tending this method of television pickup. These difficulties have been mainly in the small amount of light available on the photoelectric cell; necessitating very high amplification, with attendant noises and troubles. Development of the more sensitive caesium photoelectric cell, as well as more intelligent use of the screen-grid high-gain amplifying tubes (which, with better manufacturing, have reduced the microphonic and electronic noises) have enabled the engineers of the Jenkins-DeForest Laboratories to overcome the basic difficulties. They have achieved the undoubted advantage of the direct pick-up camera system in the television studio.

### Present Experimental Studio of the Jenkins Laboratories

While in New York, at Station W2XCR, the conventional flying-spot system is still in use, yet in Passaic, in the Jenkins-DeForest Laboratories, a model studio using this direct pick-up camera is in use. A glimpse into this studio shows, at one end, a stage around the outer edge of which are mounted groups of lamps spaced at intervals along top, bottom and both sides. These lamps are of fairly high candle-power, and their purpose is to illuminate with an even amount of light every portion of the stage. On the stage are a piano, music racks and other properties necessary for the immediate scene to be televised. Over alternate lamps are placed special optical filters. The filter on one lamp permits the red and infra-red rays to flood the stage; while the next lamp is filtered so that the blue part of the light floods the stage. The reason

Mr. Replogle, author of the present article, is widely known to the radio and television fraternity. He has just been honored with the title of chief engineer of the De Forest Radio Company.

camera, shown in the accompanying illustrations, which is capable of being used outdoors, when mounted on trucks; and used as well in studios and theatres to pick up any scene that can be brilliantly illuminated.

The idea of this camera is not new. However, it has heretofore been considered impractical by television engineers, because of the difficulties at-

\* Vice-President, Jenkins Television Corporation.

# TELEVISES *with* New Lighting System

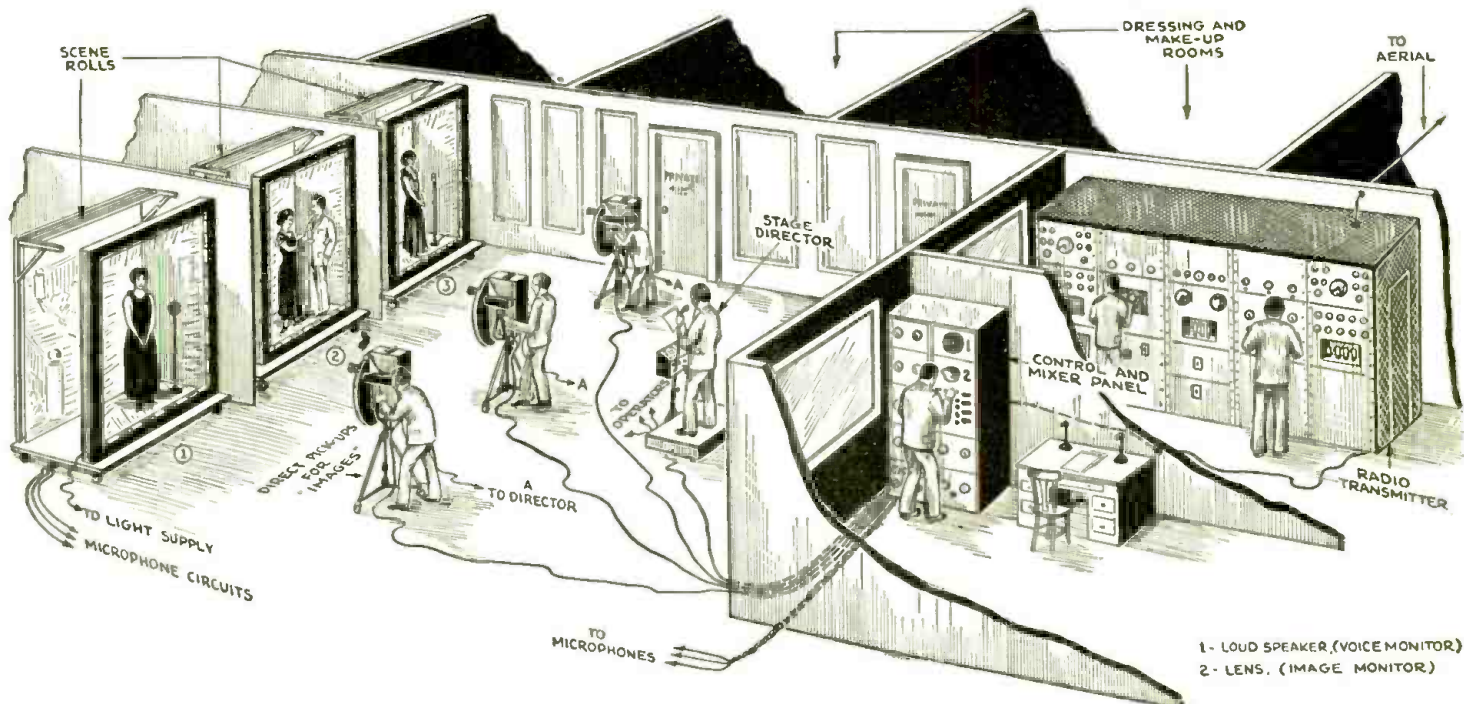

Here we see how television dramas and other entertainments will be staged, with three or more "direct pickup" cameras, this arrangement enabling the supervisor at the mixer panel to fade the images in or out as desired.

for this light-filtration is as follows: If all the lights were permitted to flood the stage with the total candle-power, the brilliance presented to the eyes of the artists would be very annoying to say the least.

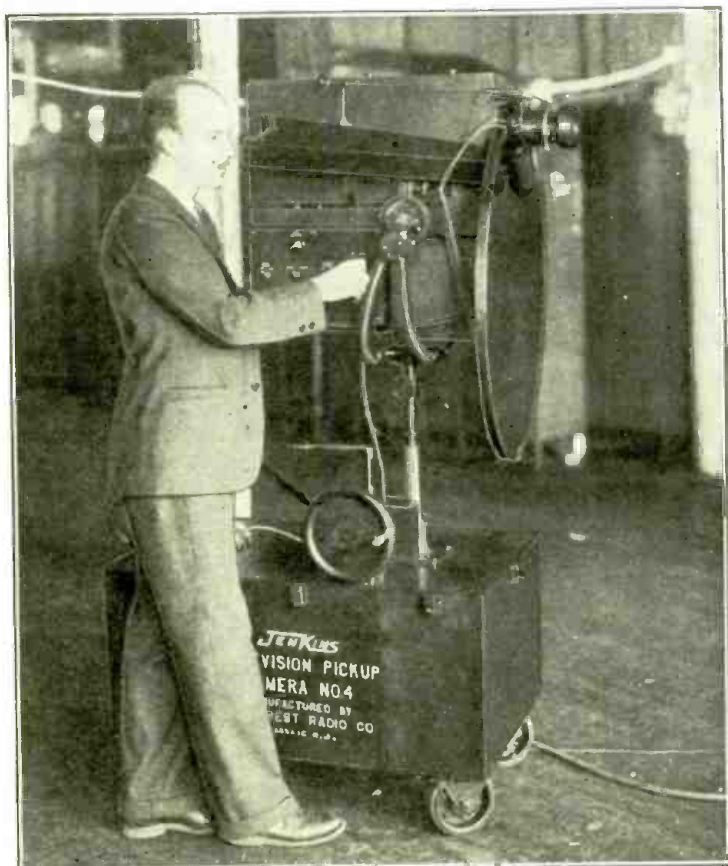

Latest model Jenkins "direct pickup" camera with mobile truck. The operator checks the image by looking into the scanner hood shown.

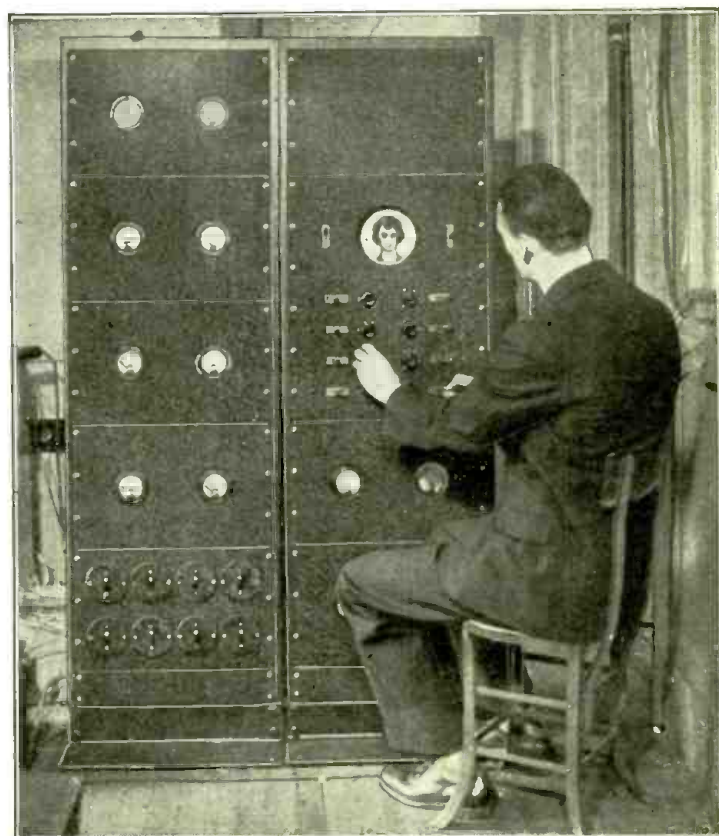

New style mixer and control panels, with image monitor, for television transmitting stations, designed by the Jenkins engineers.

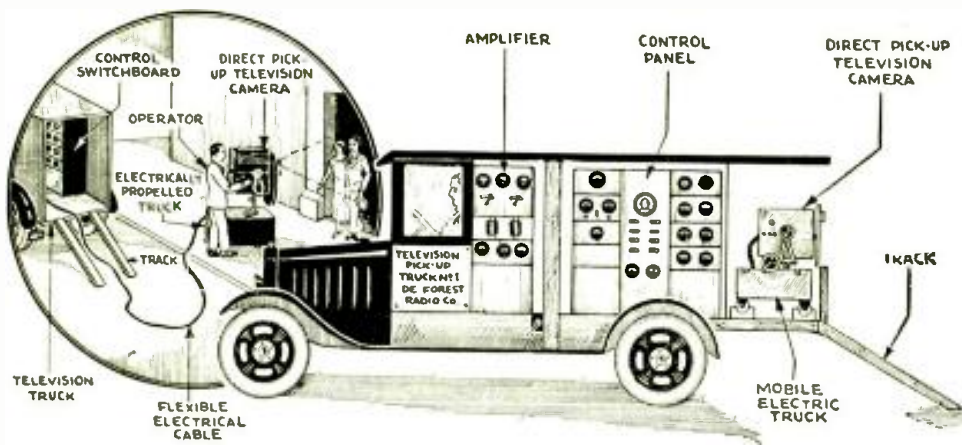

CROSS SECTION OF TELEVISION PICK-UP TRUCK

Latest portable "television pickup" equipment. The "direct pickup" television camera can be rolled down the tracks and used wherever desired. A front view of the pickup camera is seen at right.

the story by moving his camera back, refocusing as he goes; and thereby give the looker-in a wider field than previously. By swinging his camera he is able to focus on any one of several objects on the stage, as they become successively of prime importance in the sequence of the story.

**Prize Fights, Etc., Have Been Televised!**

From the foregoing brief description, the flexibility of this new camera device is obvious. With it we have been able to televise plays involving a plot of three or more people; we have been able to put on prize fights on a restricted stage, with a fidelity that would enable the looker-in to follow each blow of the contestants; we have been able to televise pianists, showing the technique of the fingers, and, of course, artists singing or speaking, reproducing the facial expressions with recognizable detail. Ballet dancers and clog dancers have been televised with excellent results. Therefore, it will be noted that, if two or more sets, with a camera before each set, were available, with the proper "mixing" or continuity selection from each of these sets, a satisfactory presentation of even intricate plots would be possible.

In the studio at Passaic, immediately behind the camera, is an open window through which, on sunny days, the camera is turned outdoors. Cars on the streets a block away, as well as signs on buildings a block or more away, are readily observed in the camera's monitor. An airplane a half-mile away can be distinguished as it crosses the field of the camera. In fact, the operators of the camera state that they can pick up better pictures on a sunny day out-of-doors, than can be secured on a specially-lighted stage.

**Bothersome Light Filtered Out**

The total amount of illumination versus the light spectrum is shown in the accompanying curve. It is noted here that, by far, the greatest brilliancy is in the yellow part of the light spectrum. Fortunately or unfortunately, the latest highly-sensitive type of photoelectric cell made with caesium has a curve as shown; the greatest response of the cell is in the blue and red portions of the spectrum, with very little response in the yellow. It is obvious, then, that all the brilliancy which is so bothersome to the eyes of the artist actually does very little good as far as actuating the photoelectric cell in the camera goes. Hence, it is feasible, with negligible loss of light, to filter out entirely the center portion of the light spectrum emitted by the lights around the edge of the stage. In this way the comfort of the artist is assured, and ample light can be secured to actuate the latest types of television pickup device.

In front of the floodlighted stage is placed a direct pickup camera, an illustration of which is shown on the cover of this magazine. The attending operator is aided by very accessible controls to focus his television camera on any portion of the stage for the desired action.

**Scenes Can Be Accurately Focused**

If a close-up is desired, he brings his camera close to the stage, refocuses the image on the photoelectric cell, and keeps the image in the center of the television field. He ascertains the focus and center of his image by means of a television monitor; and not by an optical finder—the common practise with movie cameras. In this way, he is absolutely certain just what portion of the scene is put on the air, the proportion the image occupies in the field, and how well it is focused.

Should the scenario call for a full-length stage effect, the cameraman is able, without changes of lenses as is necessary in the flying-spot, to follow



Photo above shows a lighter weight direct pickup for studio use, the photo-cell being placed behind the scanning disc and lens.



Chart (right) shows how bothersome light is filtered out in new studio lighting scheme. Full line shows distribution of incandescent flood-light over light spectrum; dotted line shows sensitivity distribution of television camera photo-cells.

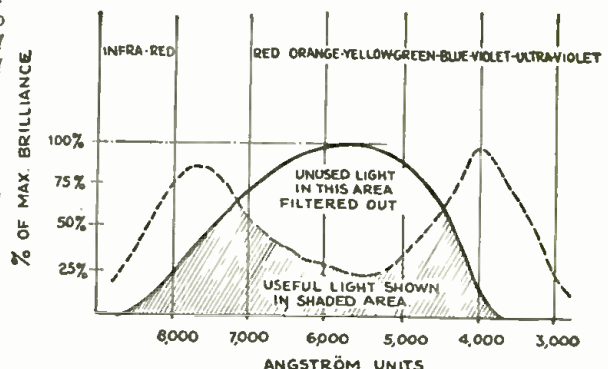

**Outdoor Pickups Now Possible**

The success in operating this camera outdoors has been such that the Jenkins-DeForest engineers are now developing a truck on which will be placed a camera, with a long flexible cable on a reel; so that the truck may be driven to a baseball game, to the arrival of some notable, or to any other outdoor event to be televised.



## In the TELEVISION EYE

AFTER all is said and done, price is still one of the determining factors in the popularity of any radio set put on the market. In the picture at the right, we see the latest model "voice and television" combination receiver, which will be placed on the market shortly, by the Western Television Corp. This receiver gives an 8-inch picture on the screen and is moderately priced—within the reach of the average man's income. The set was on exhibit during the recent Radio Trade Show held at Chicago and met with enthusiastic approval. The model is called "The Spirit of 45"

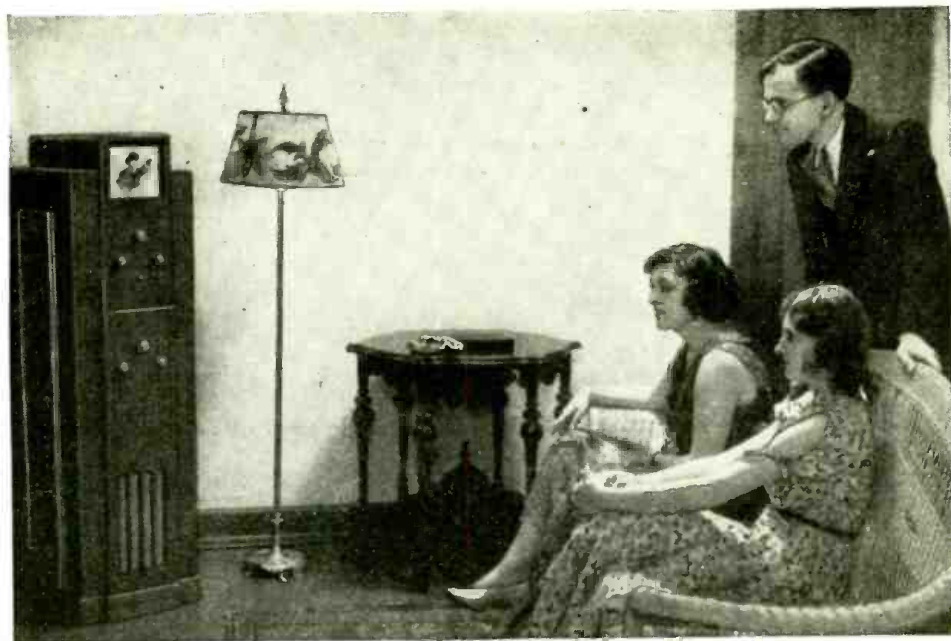

### "Krazy Kat" Does Her Stuff by Televisor



In the photo above we see the toy image of "Krazy Kat" placed on the turntable, doing her tricks before the "eyes" of the televisor.

NO doubt many people who have seen "Krazy Kat" do her tricks on the television screen, have thought it a mysterious trick, and wondered how it is all done. She dances, turns and bows gracefully on the television screen, as you sit there trying to puzzle out the means by which this entertaining trick is accomplished. To stop all the complexity and wrinkled brows, the editors have decided to let you in on the secret of how it's done. "Krazy Kat" or any other toy image

is placed on a turntable which is placed on top of a spring wound or other motor, operating on the same principle as an ordinary phonograph. As the turntable revolves, the toy image is observed at outposts where vision receivers are located. Simple, isn't it? Using this experiment, which was conducted by the National Broadcasting Company, atop the New Amsterdam Theatre, recently, as a starting point, it won't be long before marionette shows will entertain us.

### Germany Prefers blonde as "Miss Television"

THE blondes win out in Germany. Miss Evelyn Holt, a motion picture actress, was chosen as Germany's first "Television Girl." Miss Holt is regarded in Germany as a perfect Teutonic type of beauty, having beautiful, symmetrical and very clearly defined features. No girl without these natural attributes can aspire to the title.



Copyright by "The American Weekly"

A charming pose of Miss Evelyn Holt, Germany's first "Television Girl".

# T E L E V I S I O N — T o d a y

**I**N the city of Hollywood—where a great industry has been builded upon the fascinating art of illusion—where men and women play no small part in shaping the thoughts, the ideals, the architecture and the fashions of the civilized world—where the electrical marriage of sound and sight has produced a mighty force to carry America's goodwill message to the people of all nations—it seems appropriate to discuss the most recent development in the field of electrical entertainment—*Television*.

Where is television? When will it be ready for the home? What form will it assume? How about the necessary television transmitting stations? What are its likely effects upon the established radio and motion-picture industries?

These are pertinent questions, frequently asked. The answers are of peculiar significance to Hollywood; yet thinking men and women of all the world likewise are evincing keen interest.

Let us, then, preface any discussion of this subject with the general statement that television, or the process of transmitting images by radio, still is in the laboratory stage. True, rapid progress is being made. The sweep of events during 1930 and the first months of 1931 has been very substantial indeed. Television has been brought definitely nearer commercial development by the research and technical progress of the Radio Corporation of America during this period.

## Where Is Television?

One year ago, television was a subject of engineering conversation and a topic for technical dispute. It now has progressed beyond that point. Today, transmission of sight by radio is a matter of accomplishment, not of speculation.

It must be understood, however, that the present sporadic activities in this direction cannot be classed as a practical service. They are purely experimental; but as such they deserve encouragement and merit public interest.

The present status of television might be likened to the condition of radio in the immediate pre-broadcasting era, when amateurs were beginning to hear faint sounds through the air. Voices and music were passing through space in those early days of radio; comparably, there are actually some images passing through the air today. They are being received by established experimental stations, and by amateur operators in various sec-

tions of the United States. In this connection, it should be observed that the early success of radio broadcasting was stimulated in no small measure by the amateur "wireless" operators of that day. Similarly, the amateur operator in television is now playing his part in the development of this new service.

## The Form and Progress of Television

The next stage—and I should anticipate its realization by the end of next year—should find television comparable to the earphone stage of radio. At this point, the public may well be invited to share in its further unfolding.

By that time, television should attain the same degree of development as did radio sound broadcasting in the early period of the crystal set. This does not mean that the actual physi-

---

**Everyone should read what Mr. Sarnoff has to say about Television and its future. Mr. Sarnoff is, undoubtedly, the biggest man in commercial Television and Radio today, and we are sure our readers will find most interesting, the ideas he has expressed in this article.**

---

cal structure of the first television receiver will be similar in any way to the crystal receiver. The similarity will lie in the class and condition of the service; the visions which first come through the air to the public will be of the same embryonic quality as the first faint sounds which sent mother hurrying to the earphone of the boy's crystal set in the attic.

When television reaches this stage, rapid strides may be expected, comparable perhaps with the growth and development of broadcasting of sound. The progress to follow should make possible the projection of moving images on a screen on the wall. Reception of sight by radio then will be comparable to the loud-speaker stage of sound reception.

The Radio Corporation of America is conducting its present experimental developments in television through a large research staff in the RCA—Victor plant at Camden, New Jersey. When television emerges from this experimental stage it will be handled as a service by the National Broadcasting Company.

## Television Transmitting Stations

Before television reaches the practical stage of service, it is necessary

that several experimental stations for the transmission of sight by radio be established.

The Radio Corporation of America contemplates building several such stations by the end of next year. One will be on the top of the new fifty-story RCA Building at 570 Lexington Avenue, New York City; another will be on a still higher building in New York City. These sites have been chosen because height is an important technical factor in the successful transmission of sight by radio. These two stations probably will be located in such a manner as to serve New York City and its vicinity.

A third station will be located on the Pacific Coast.

Additional experimental stations may be located in other sections of the country.

Through the operation of these experimental stations, we expect to obtain exact information and practical field experience, which are required before definite plans can be developed for a television service of nationwide scope.

## Television Will Help the Radio Industry

The effect of television upon the present established radio industry will be beneficial. There will be no interference between the broadcasting of sound and of sight. These services will supplement each other and complete the impression upon the human mind by reaching it through both the ear and the eye. Television broadcasting stations will operate on wavelengths different than those now used for the broadcasting of sound. An entirely different receiver will be necessary; radio sets now used for sound reception are not equipped to receive television.

In the practical sense of the term, television must develop to the stage where stations will be able to broadcast regularly visual objects in the studio, or scenes occurring at other places through remote control; where reception devices shall be developed that will make these objects and scenes clearly discernible in millions of homes; where such devices can be built upon a principle that will eliminate rotary scanning discs, delicate hand controls and other movable parts; and where research has made possible the utilization for sight transmission of wavelengths that will not interfere with the use of the already overcrowded channels in space.

The Radio Corporation of America is pursuing the foregoing development aggressively in its laboratories and

# and Tomorrow

*David Sarnoff*

President of the  
Radio Corporation of  
America



will not attempt to market television equipment commercially this year; it is concentrating its efforts upon the primary technical developments to be completed before undertaking the manufacture and sale of television sets on a commercial basis.

### Television in the Home Will Not Interfere with Motion Pictures in the Theater

The motion-picture industry need experience no alarm over the impending advent of television.

Transmission of sight by radio will benefit not only the radio industry; it will also prove a welcome stimulant, a pleasant tonic to all the entertainment arts.

There will be no conflict, between television in the home and motion pictures in the theater; each is a separate and distinct service. History confirms the fact that the creation of a new service for the public does not result in the elimination of an older service, provided each has something of its own to give. On the contrary, many examples might be cited to prove that the reverse is true. The telephone did not displace the telegraph. The radio did not displace the cable. The incandescent lamp did not displace the candle; more candles are being sold today than before the creation of the incandescent lamp. And television in the home will not displace the motion picture in the theater.

Man is a gregarious creature. Granting that we can develop 26,000,000 potential theaters in the homes of America, public theaters will continue to operate because people will go there in response to the instinct for group emotions, and to see artists in the flesh. These are human demands which television in the home cannot satisfy.

### Television Will Expand the Artists' Field

Now, let us consider the human equation as it may be affected by the new development of television, for the human factor is the most important one in the creation of motion pictures.

In reflecting upon the entertainment arts in general, and the motion-picture industry in particular, one is impressed by two essential elements which must be regarded as their life blood. The mechanical age with its

(Continued on page 313)

David Sarnoff, President of the Radio Corporation of America, who, in the accompanying article expresses his thoughts on the commercial application and development of Television. Mr. Sarnoff combines a happy combination of technical and business abilities, and what he has to say on Television proves most interesting. Undoubtedly, Television will receive a great impetus this coming fall and winter.

### High-Spots in Mr. Sarnoff's Article

¶ The present status of television might be likened to the condition of radio in the immediate pre-broadcasting era. The R. C. A. is conducting its present experiments in television at the R. C. A. Victor plant at Camden, N. J.

¶ When television emerges from its experimental stage, it will be handled as a service by the National Broadcasting Company.

¶ The R. C. A. contemplates building several experimental television transmitting stations by the end of next year.

¶ The effect of television upon the present established radio industry will be beneficial. There will be no interference between the broadcasting of sound and of sight. These services will supplement each other and complete the impression upon the human mind, by reaching it through both the ear and the eye.

¶ There will be no conflict between television in the home and motion pictures in the theatre; each is a separate and distinct service. The potential audience of television, in its ultimate development, may reasonably be expected to be limited only by the population of the earth itself.

¶ Television broadcast service of tomorrow will demand a constant succession of personalities, a vast array of talent, and a tremendous store of material, with a great variety of scene and background.

# What TELEVISION INVENTORS Are Doing



The dark-eyed beauty above is none other than Miss Violet Hodgson, chosen at Chicago as "Miss Television, 1931".

Left: Miss Violet Hodgson — "Miss Television, 1931" — at the Radio Manufacturers Association "Trade Show", held in Chicago. The two well-known geniuses, Messrs. Hollis S. Baird and U. A. Sanabria, conducted the experiments. Miss Hodgson, whose dark eyes and wavy locks make her an ideal subject for televising, is shown standing alongside of the lens, on which the reproduced image, transmitted from another room in the hotel, appears.

Right: Good idea for "built-in" television screen. This happens to be a midget "movie" screen which reproduces in miniature, the same feature shown on the main screen of a theatre. Rays of light deflected from a point near the lantern of the theatre's projector, throw an image on the small screen. A loudspeaker reproduces the sound accompaniment. — Sterling Gleason.



Los Angeles theatre has midget screen in foyer which reproduces miniature of main picture. Good style for built-in Radiovisor.

## "All-at-once" Television Transmission of Image

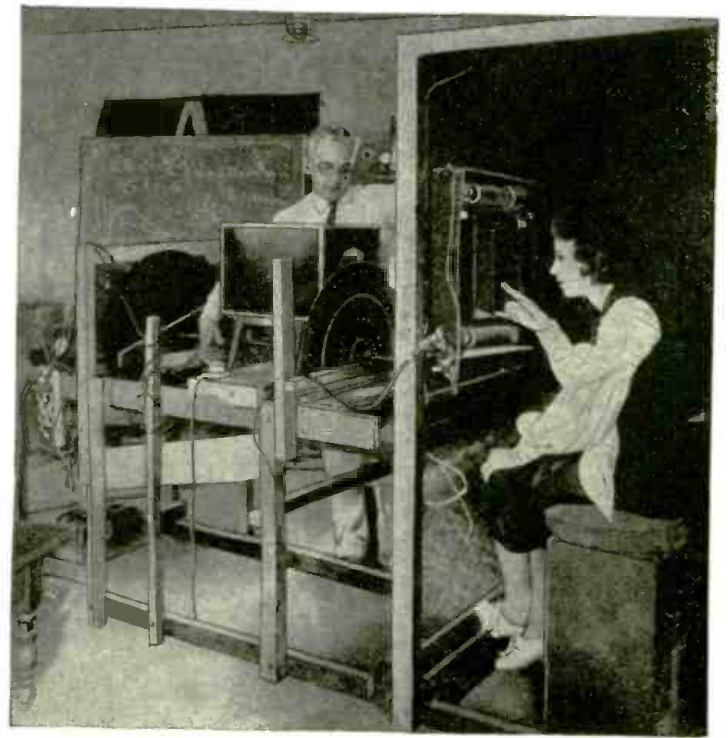
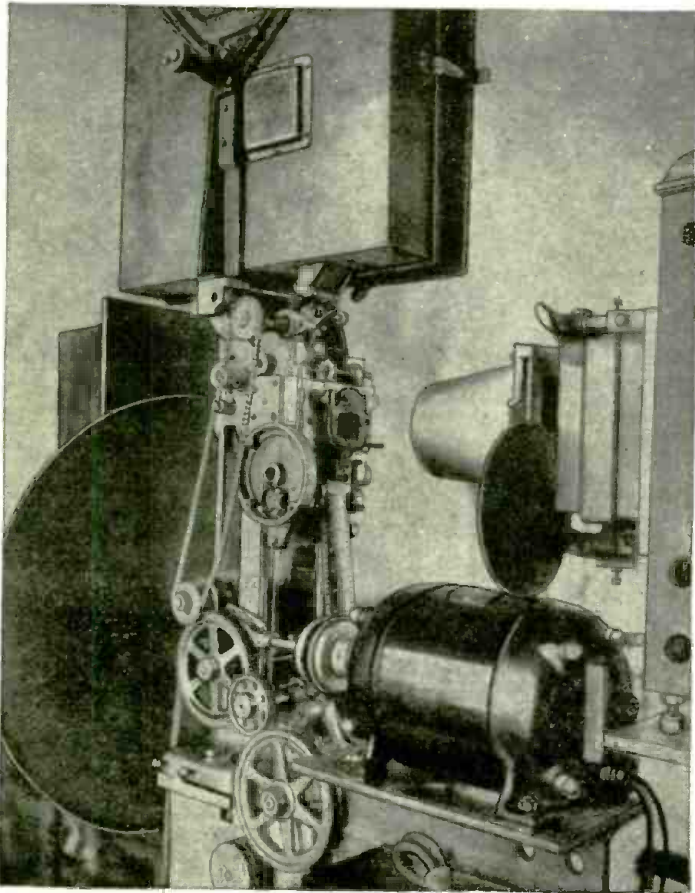

Left: Apparatus to transmit image and voice. Mr. Gilbert C. Lee, seen in photo at right, is supervising part of the experiments, conducted by the members of the Los Angeles Television Society. The old method of "dots" which in aggregate form, built up the image, is discarded in favor of this new method, which transmits the object televised in its entirety, reproducing it in the space of 15 seconds. Line drawings, etc., are televised and recorded on film or bromide paper.

# COLUMBIA IS TELECASTING!

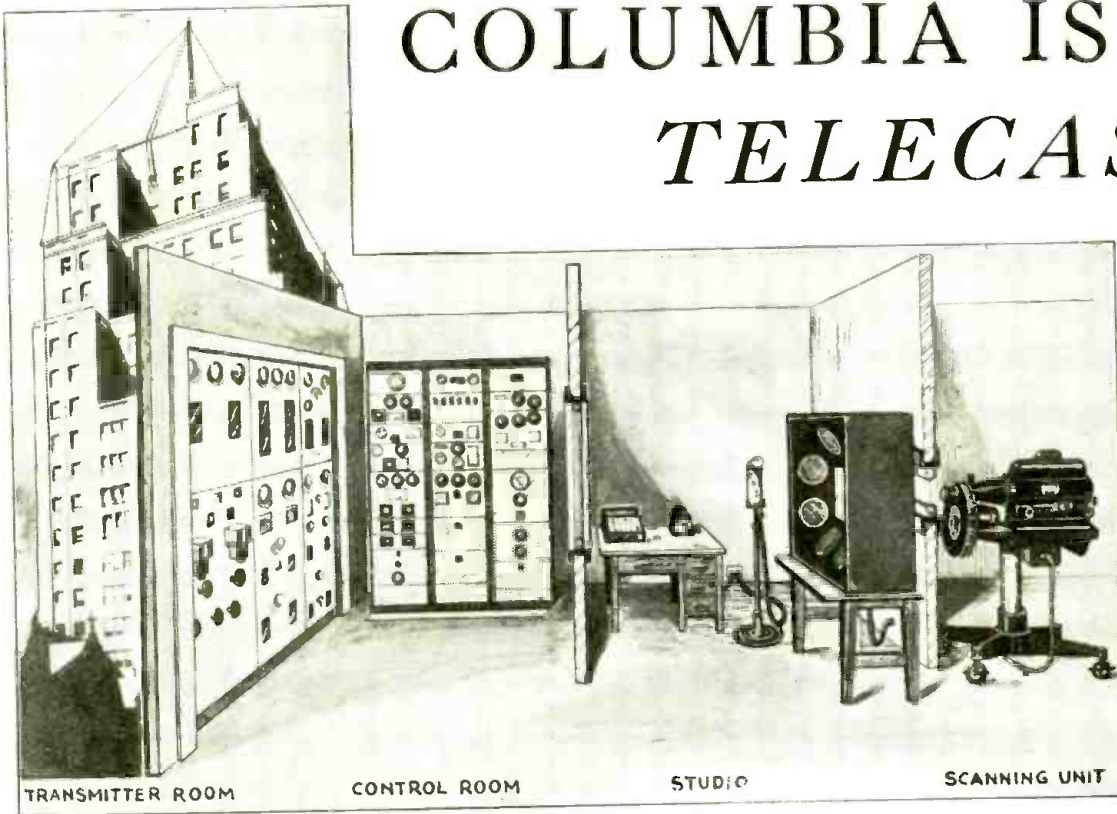

The Columbia Broadcasting System officially opened its experimental television station, W2XAB on July 21st, using 60 line scanning at 20 frames per second. A 60-hole disc revolving at 1200 r.p.m. is necessary to "pickup" the Columbia images. Frequency 2750-2850 k.c. Voice on 6120 k.c.

General view of Columbia Television Studio, showing radio transmitter and control rooms, studio where artists are scanned and the arc used for scanning.

**W**ITH civic, radio and stage celebrities participating, the Columbia Broadcasting System officially opened its experimental television station, W2XAB, Tuesday, July 21. The opening of the station follows several weeks of tests in which clear reception of W2XAB's signals were reported from cities as far away as Boston, Hartford, Baltimore, Camden, Schenectady and Philadelphia. Although sight transmission of the premiere program was limited geographically to a comparatively small section along the Eastern seaboard, the sound transmission was carried to most of the 85 outlets on the world's largest network.

Mayor James J. Walker of New York City lifted the curtain from the photo-electric cells, formally marking Columbia's expansion to *visual*, as well

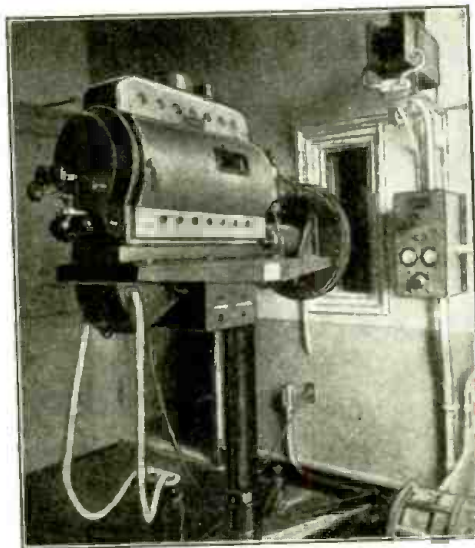

as *audible* entertainment. The Mayor had been asked to introduce to "lookers-in" (in addition to a nation of listeners-in) Miss Natalie Towers, Wellesley graduate, whose beauty televised so attractively that she became the first girl ever to be signed exclusively by a network for television appearances.

Edwin K. Cohan, technical director of Columbia, delivered a ten-minute

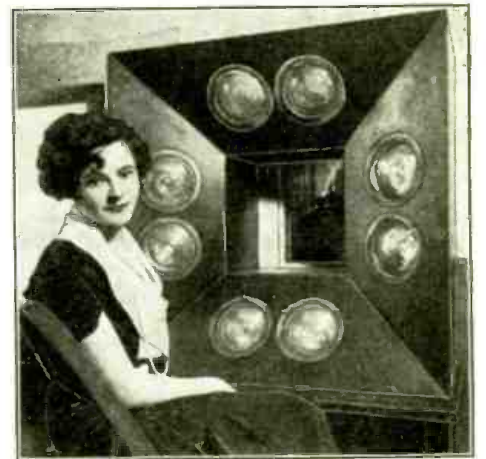

Miss Natalie Towers, who is "Miss Television" of the Columbia Broadcasting System.

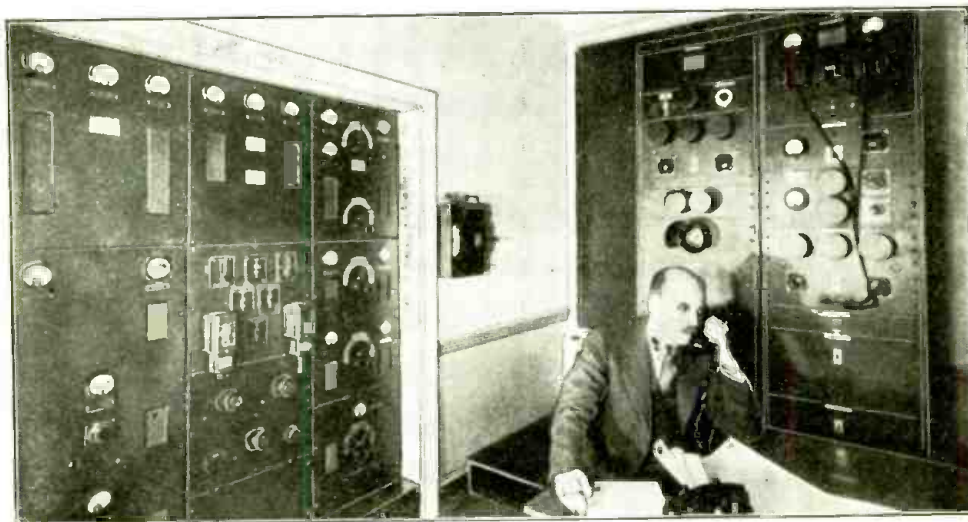

Radio transmitter panels at left; control panels with monitor at right.

address on "What to Expect of Television".

Transmitting apparatus and antennae systems are adjacent to the studio located on the 23rd floor of the Columbia Building, 485 Madison Avenue, New York. The equipment is of the most modern design, representing latest advances in the science of

(Continued on page 317)

# HOW I OBTAIN 6½ FOOT TELEVISION IMAGES

An Interview With ULYSSES A. SANABRIA

By H. Winfield Secor

Sanabria is one of the most brilliant geniuses in Television today. Although but 24 years of age, this young engineer has exhibited the largest television images thus far shown and a gigantic television image, 10 by 14 ft., has been promised in a demonstration at the New York "Radio Show" in September. The technical information here presented on the Sanabria System is brand new and authentic, as it comes from the inventor himself.

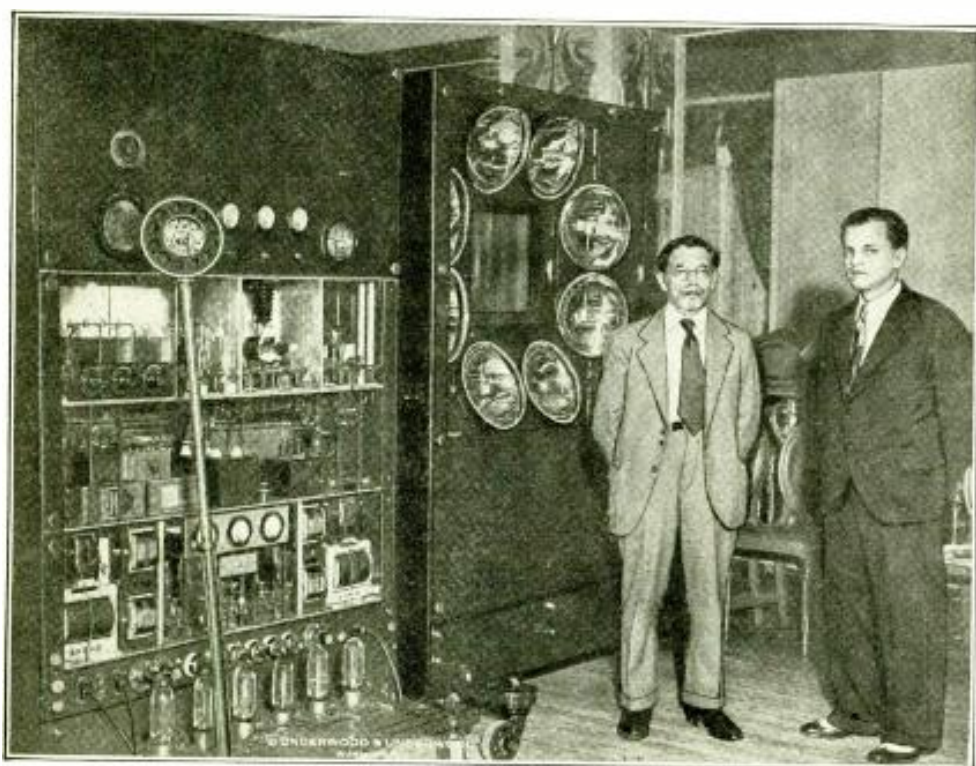

Photo above shows Mr. Sanabria at extreme right, with Dr. Louis Cohen, distinguished radio engineer of Washington, D. C., standing in front of the Sanabria television amplifier and photo-cell pickup.

**A**MONG the outstanding geniuses in the field of American television developments, we find the name of U. A. Sanabria, as a shining light. This 24-year old inventor has startled and agreeably surprised all those who have seen his exhibition of "giant" television images. Those who visited the recent Radio Trade Show at Chicago had an opportunity to see what Mr. Sanabria had to show in new television developments. He also demonstrated his apparatus recently in New York City to the members of the technical and daily press.

Large television images have been produced before; but the main feature of the Sanabria television system is the excellent quality of the images reproduced.

Having witnessed a demonstration of Sanabria's large (6½ feet square)

television images, and having heard the most flattering comments from Capt. Dinsdale, and many other experts who witnessed the demonstration, I arranged to interview Mr. Sanabria with a view to procuring for our readers further details on his system of television. The accompanying diagrams and photograph will help to make the questions and answers clearer.

### Photo-cell Pick-up and Source of Light

**Q.** How are the eight photo-cells which pick up the image at your television transmitter connected?

**A.** The eight caesium cells are connected in parallel to a common circuit, leading into a pre-amplifier of two stages, which is mounted close to the photo-cell group.

**Q.** Why is a pre-amplifier used close to the photo-cells themselves?

**A.** To reduce the capacity to ground of the input lead wires.

**Q.** What kind of reflectors are used with the photo-cells?

**A.** Hemispherical chromium-plated reflectors, having the photo-cells placed approximately at the center or focal point of the reflector.

**Q.** How many million times is the photo-cell current amplified, before it reaches the gas-arc tube at the receiver in your demonstration set?

**A.** 2,000,000 times, approximately.

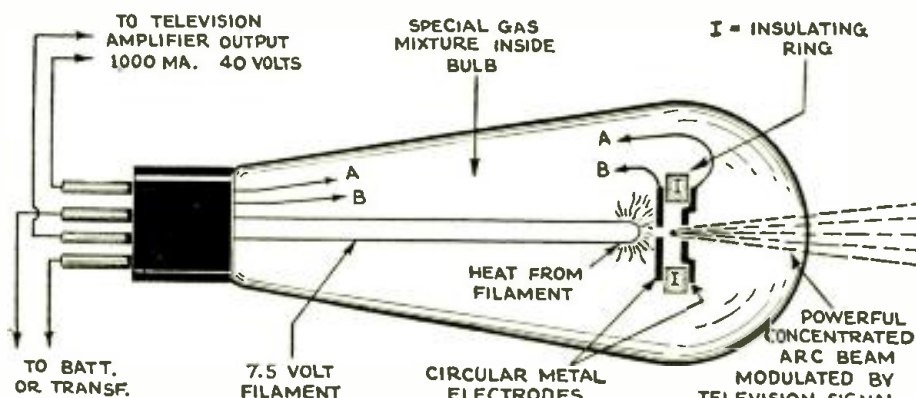

Schematic diagram of Taylor gas "Arc" tube, used by Sanabria in producing his gigantic television images. The television signal produces a highly concentrated "arc" discharge between the electrodes, as shown and the heater renders the discharge path more conductive.

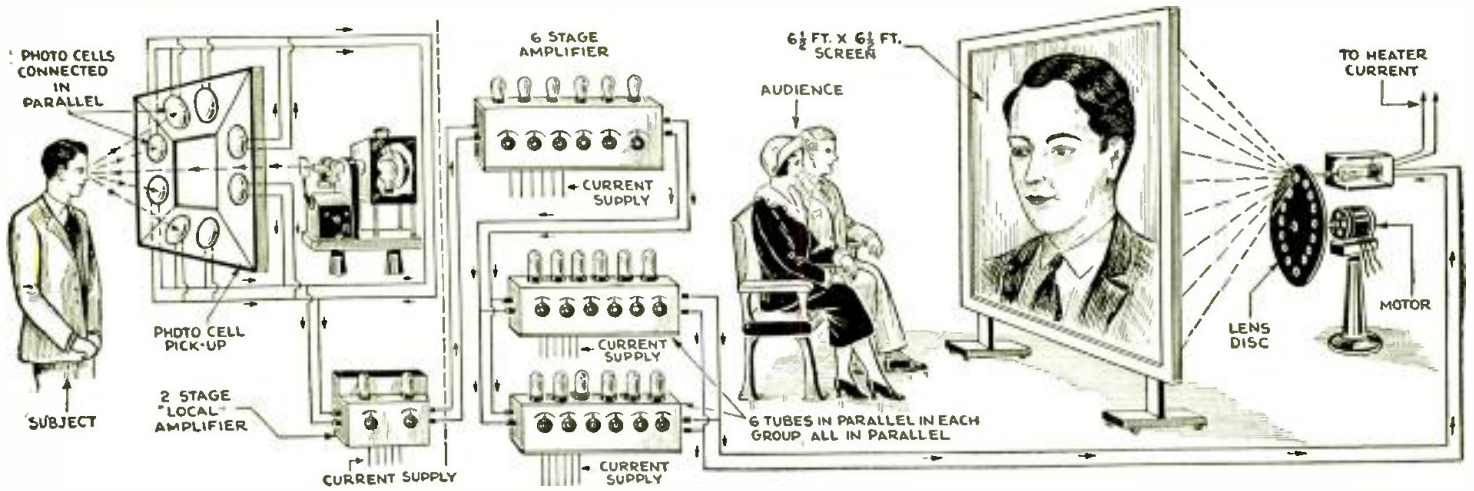

Diagram showing line-up of Sanabria "giant-image" television system, with various stages of amplification indicated. The twelve large amplifier tubes of the final stages are connected in parallel to supply the 1,000 M.A., for operating the gas "Arc" tube, used in the receiver.

Q. Do you use an arc or an incandescent lamp as the source of light at your transmitter?

A. I use a 900-watt projection lamp rated at 1,800 candle power, or about 1/2 watt per candle. The light from this lamp passes through condensing lenses, thence through a 45-hole revolving scanning disc (containing no lenses, but simply holes) and then through a projection lens onto a glass mirror, of the surface-silvered type, which reflects the scanning beam onto the object to be televised. The reflected light beams from the face of the subject, for example, fall on some of the ring of caesium photo-cells, which in turn cause to be developed corresponding electric currents which are then passed into the amplifier. Four different sets of lenses are mounted on a turret, so that any one of the four can be used at will. Each lens has a different focal length.

**Amplifier Is "Heart" of the Sanabria System**

Q. What do you consider the principal improvement in your television system which accounts for the hereto-

fore unattainable high quality of the large images you obtain?

A. The major part of my research of the television problem has been on the amplifier. This amplifier gives practically distortionless amplification of all frequencies from one-quarter of a cycle to 50,000 cycles and will pass frequencies much higher than 50 kc.; frequencies up to 100 kc. pass through it at times. After all, the amplifier is the real "heart" of the television system. If you have photo-cells which will pick up and respond to frequencies of say 50 kc., and then attempt to pass these frequencies through a poorly designed amplifier, many of the most important will be cut off; with the result that a poor image will be seen on the screen. You therefore see the importance of a well-constructed and exceedingly well-designed amplifier in television.

Q. Do you use resistance coupling in your amplifier?

A. I use a combination of resistance, impedance and capacity coupling in various combinations, which I have found to give the best results after

much careful research and lengthy tests.

Q. How many stages of amplification do you use between the photo-cells at the transmitter, and the Taylor gas-arc tube, which you employ to project the large images on the 6 1/2-foot square screen?

A. There are two stages of amplification in the pre-amplifier, immediately following the photo-cells; then come six stages of amplification, one tube to each stage; followed by a third amplifier group, containing 12 special Taylor amplifier tubes, of fairly large size (equivalent to the RCA 845 amplifier tubes). These twelve amplifier tubes in the final group are arranged in two sub-banks of six tubes each; all the tubes feeding in parallel into a common output circuit. This large bank of amplifiers is required to yield the 1,000 milliamperes necessary to excite the Taylor gas-arc tube used in my television screen system.

Q. What is the plate voltage supplied to the large Taylor amplifier

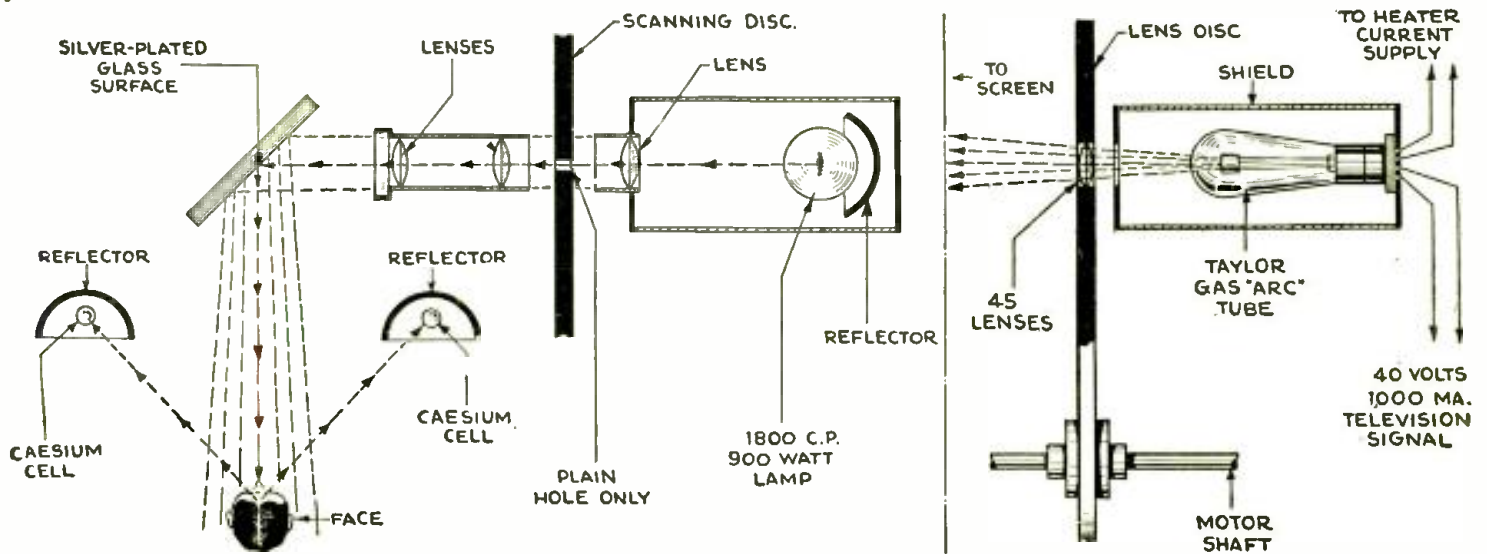

Above we see a plan view of the Sanabria photo-cell pickup; the flickering light beam coming from the scanning disc and lenses is projected onto the face from a mirror. Diagram at the right shows Taylor gas "Arc" tube and lens type scanning disc at receiver.

tubes in the final amplifier group?

A. 40 volts.

### How Sanabria Produces His Large Image

Q. We understand that you are using the new Taylor gas-arc tube, which corresponds in physical size approximately to a '50 type standard amplifier tube; tell us something about this new "arc" tube. How much more efficient is it than a Neon Crater tube, and also is it water-cooled or air-cooled?

A. The Taylor gas-arc tube operates on an entirely different principle than the Neon Crater tube, and it will stand much more current for a given size tube and a given luminosity, than would a Crater tube of the same size. Crater tubes, to handle any great amount of power, must have their electrodes water-cooled. But, with a Taylor tube the elements are air-cooled, even in the size we use for reproducing the image 6½-ft. square, which you saw. The tube you saw demonstrated actually had 1000 milliamperes passing through it at a potential of 40 volts; this "40 watts" of modulated energy being the television signal as it comes from the amplifier.

The arc tube has an electrically-heated cathode. By comparison with the Neon Crater tube, the Taylor gas-arc tube will yield as much as nine times the luminosity—both tubes being considered of similar size. In the Taylor tubes, suitable design of the electrodes results in a concentrated discharge of the television signal current in the form of an arc, yielding a brilliant spot of orange-colored white or roto-gravure-brown, light which is passed through the lenses on to the projecting screen.

### Concerning the Scanning Disc and Screen

Q. Do you use a lens disc, or simply a plain-hole disc at the receiver?

A. The scanning disc used at the receiver is one of the largest, if not the largest, lens disc ever built; it carries 45 specially made lenses each about 3 inches in diameter. This disc measures 45 inches in diameter and rotates (in the demonstration set) at 900 R. P. M., or 15 times per second. This disc is driven by a synchronous three-phase A.C. motor, operated from the A.C. laboratory supply circuit. No optical system aside from the lenses in the lens-disc is employed at the receiver.

Q. What kind of a screen do you project the large (6½-ft. square) image onto, and where is the audience situated with respect to the screen?

A. The revolving lens disc at the receiver is placed about six feet behind the glass screen, which is a sheet of thick glass, sandblasted on one side. As you saw in the recent demonstration, the various-sized images can be projected onto the screen, by moving either the screen, or the projecting mechanism, thus varying the distance between the lens disc and the screen. The audience is usually seated at least 40 feet from the front of the screen, when I am projecting a large image, about 6½ feet square. When I reduce the size of the image to 3 feet square, the spectators may move closer to the screen, or to a distance of about 20 feet from it.

Q. How do you transmit the voice in the demonstration set-up?

A. I employ the usual microphone, similar to those used in the radio broadcast studio, with an A.C.-operated voice amplifier, of two to three stages, feeding into a dynamic speaker, mounted below the projection screen at the receiver.

## The "See-All" Scanner Kit

ONE of the latest television scanner kits appearing on the market is the "See-All", a picture of which appears herewith. One of the features about this scanner kit is its nominal price coupled with excellent engineering and workmanship.

Special care has been given to the scanning disc which after all is, we might say, the real heart of any television receiver. The neon lamp will pulsate with the television signal currents, that we know beforehand, but if a poorly made scanning disc is revolved in front of the neon tube, poor results will naturally be obtained.

Actual demonstrations of the "See-All" kit proves the manufacturer's claim that it does produce an excellent brilliant image. One of the reasons for this extra fine image is that the holes in the disc are square, not round, thus providing a far greater illumination. The disc is sold separately at a very low price which is interesting news to all "telefans." Another feature of this disc, which has its holes punched in a special aluminum alloy, is that a double spiral of holes is provided, which greatly simplifies the framing of the image.

The "See-All" scanning disc is both dynamically and statically balanced; the scanning holes measure .0085 inch on a side. The "See-All" scanner kit comprises a particularly fine disc, 12 inches in diameter, and which also comprises the six-toothed laminated iron "phonic motor" wheel and copper disc for the Eddy current motor; to-

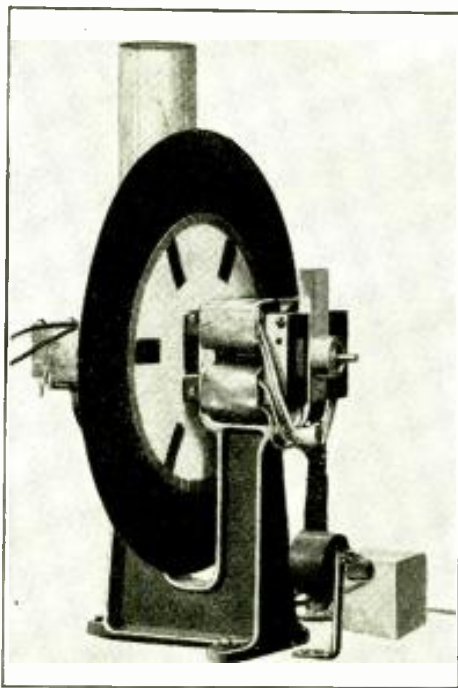

The "See-All" television scanner assembled from the kit. The disc has 60 square holes arranged in a double spiral to facilitate framing the image. The kit contains all iron cores and windings for both driving and phonic wheel motors, speed regulating rheostat, by-pass condenser, neon tube, socket, support and shield, stroboscope disc, instruction book and assembly blue-prints, together with scanning disc and phonic wheel.

gether with the laminated iron cores and windings for the Eddy current

and phonic wheel motors; main shaft of steel, with new style, self-adjusting bronze bearings, which are simple to mount and trouble-proof. A stroboscope disc, containing equally spaced black marks on it is furnished, and when viewed in the light from a 110-volt 60-cycle incandescent lamp, the black marks appear stationary when the disc is rotating at 1,200 r.p.m.

A speed regulation rheostat and by-pass condenser are provided in the kit. The kit also contains an aluminum housing for the neon lamp, as well as a socket and a socket support.

A shadow box and lens assembly, which is not absolutely essential, to view the image, is supplied at a slight additional cost. The motor support frame is a single heavy casting of special aluminum alloy and it affords an unusually rigid support for all of the windings and iron cores, for both the phonic and main driving motors.

The kit comes complete with instruction book and blue prints, showing just how to assemble the scanner and giving data on a short wave television receiver as well.

### Television License Given R. C. A.

Experimental television station, W3XAD of the R. C. A.-Victor Company of Camden, N. J., received a license on July 22nd, to cover a construction permit. The station will use 2,000 watts power and operate on frequencies of 43,000 to 46,000 kilocycles, 48,500 to 50,300 kilocycles and 60,000 to 80,000 kilocycles.



# Some Interesting Optical Features in TWO-WAY TELEVISION\*

Recent developments by the Bell Telephone Laboratory research staff, include improved scanning light and photo-cells to give more natural tone values to images; use of incandescent lamp instead of arc; improved lighting of booth and a new lens system for the receiving scanner.

By HERBERT E. IVES

Television Specialist; Member Technical Staff, Bell Telephone Laboratories

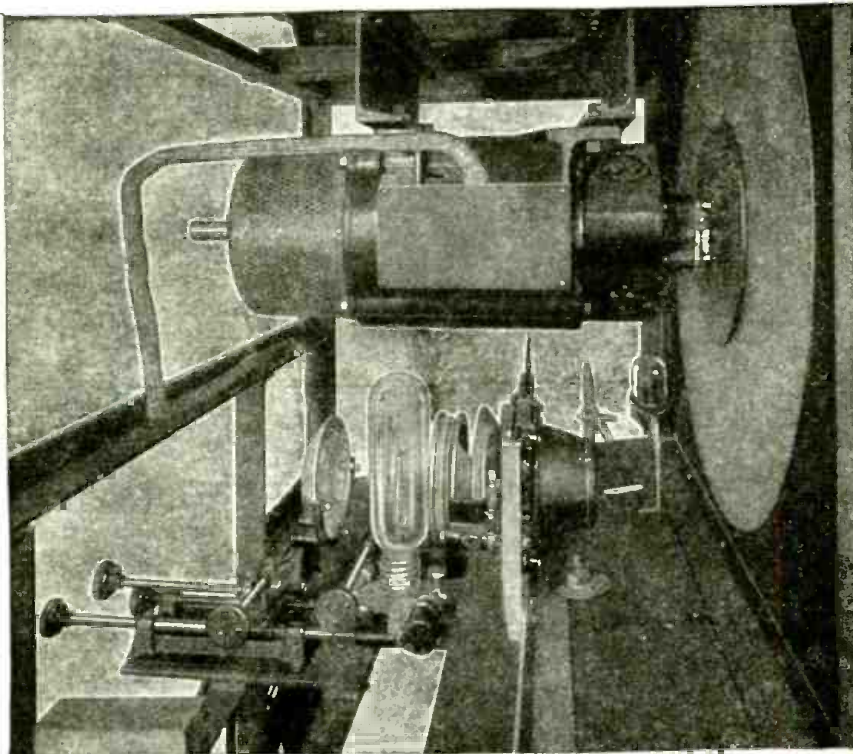

Fig. 1—Incandescent lamp of high C.P., used for scanning light at transmitter.

IT IS an inherent feature of the two-way television system that either user is continuously scanned as he views the image from the distant station. The beam scanning method,<sup>2</sup> by which a beam of light sweeps over the subject's face, enables the scanning operation to be performed with a minimum amount of light. Even so, because of the relatively low intensity of the television image, it is necessary to reduce the intensity of the scanning beam in every way possible. In the two-way apparatus as first operated, advantage was taken of the fact that the photoelectric cells employed, which were of potassium, were principally sensitive to blue light. The scanning beam derived from a high power arc lamp was accordingly passed through a deep blue filter, which reduced the photoelectric efficiency of the beam very little, but because of the relatively low visual value of blue light, effectively reduced the brightness of the

beam many times. The user of the apparatus saw, above the incoming image, merely a mild blue spot of light, which did not interfere with his vision.

A disadvantage of the use of blue light, which was anticipated, and found in practice to be quite real, was that dark, tanned, or ruddy complexions were rendered as altogether too dark, in comparison with whites such as the ordinary linen collar. The effect is precisely that encountered in the earlier photographic processes before color sensitive plates and color filters were available. While this defect was minimized by the use of a dark background, and to some extent by chopping off the highlights by electrical means, it was recognized as undesirable.

One recent improvement in the apparatus is a change in the nature of the scanning light, whereby, without sacrificing the general principle of us-

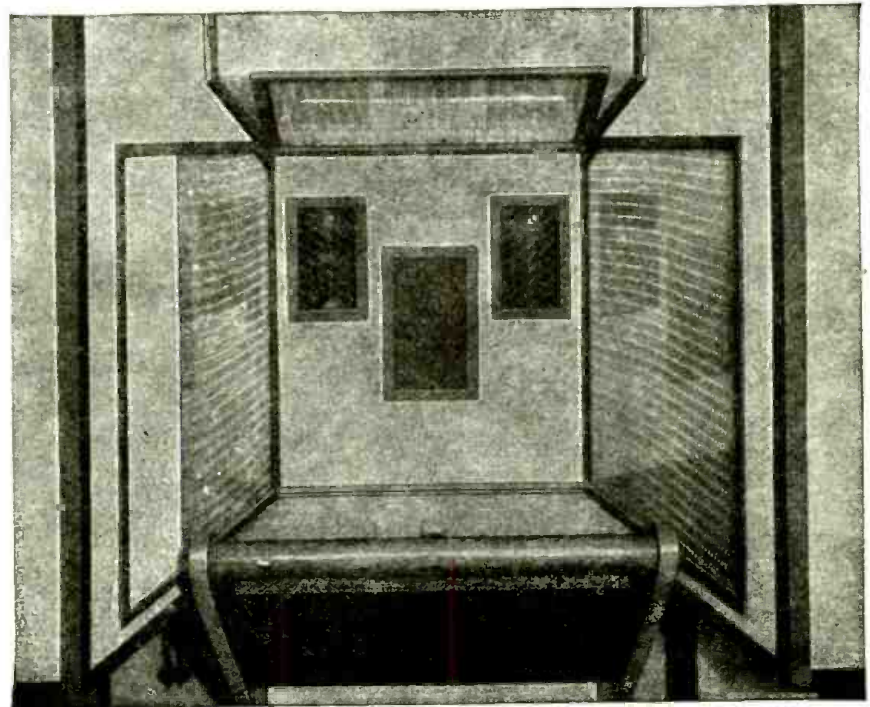

Fig. 2—Interior of two-way television booth, showing location of two caesium cells above and to either side of scanning and viewing aperture.

\* *Jour. Optical Soc.*, Feb., 1931. Reprinted by permission of Bell System Technical Journal.  
<sup>1</sup> *Bell Sys. Tech. Jour.*, July, 1930.  
<sup>2</sup> *Jour. Optical Soc.*, March, 1928.

ing visually inefficient but photoelectrically efficient radiation, the proper balance of tone values in the face is restored. This has been accomplished by adding to the battery of blue sensitive potassium cells, a group of red sensitive caesium oxide cells, and scanning by purple instead of blue light, that is, both ends of the visible spectrum are used in place of one end.

In making this change, a number of others were involved, most of which resulted in simplification or improvement. One important alteration was the substitution for the arc lamps previously employed, of incandescent lamps of a type available from motion picture projection practice, as shown in Fig. 1. The lamp employed has for its radiator, four vertical helical coils of tungsten wire, and is furnished with a reflector which images the coils back on the intervening spaces. An efficient condenser system throws a brilliant rectangular image on the back of the scanning disc, which is substantially uniform over the whole field. With this unit, the scanning beam as it leaves the projection lens is somewhat larger in diameter than the beam as produced from the arc. Consequently, for positions away from the focused image of the disc holes, the scanning beam is larger than before, with some resultant loss in the range of sharpest definition. Since, however, the user of the two-way apparatus is seated in a fixed chair, he has little opportunity to move far out of the plane in which the disc holes are focused, so that this objection is not serious. The advantages of this substitution were two-fold. First was a great gain in simplicity of operation and maintenance. Second, the incandescent lamp, being a lower temperature radiator, radiates relatively many times as much red light as does the arc, for the same amount of blue. Consequently, once an incandescent lamp unit was found which gave the amount of blue light required for the potassium cells, the great excess of red light made possible the use of relatively few caesium oxide cells. Since these are intrinsically somewhat more sensitive than the potassium cells, the net result was that a red signal comparable with the blue signal could be added by the installation of only two caesium cells, each of less than half

the electrode area of the potassium cells.

It was found most convenient to mount the two caesium oxide cells directly in front of the observer, to either side of the microphone, and above the opening in the booth through which the scanning beam enters, and through which the incoming image is seen. This arrangement is shown in Fig. 2. The only objection to placing the cells in this position is that they encroach somewhat into the region where reflections of the cells (which are virtual light sources) are likely to be seen reflected in eyeglasses. Since, however, the head is normally directed somewhat downward, cells placed in these upper corner spaces are not serious offenders in this respect.

Two other features of the two-way system which needed revision when the caesium cells were adopted, were the variable angle prisms used to direct the scanning beam upward or downward, depending on the user's height, and the general illumination of the television-telephone booth. As to the variable angle prisms, the only

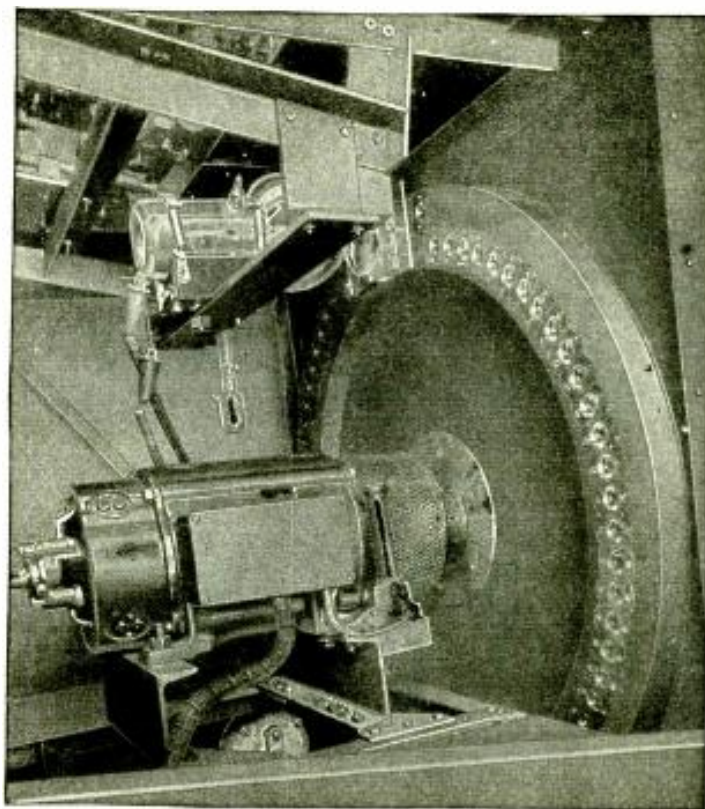

Fig. 5—Scanning disc with special arrangement of condensing lenses as used at the receiving ends of two-way television system, as here described by Dr. Ives, famous television inventor, connected with the technical staff of the Bell Telephone Laboratories.

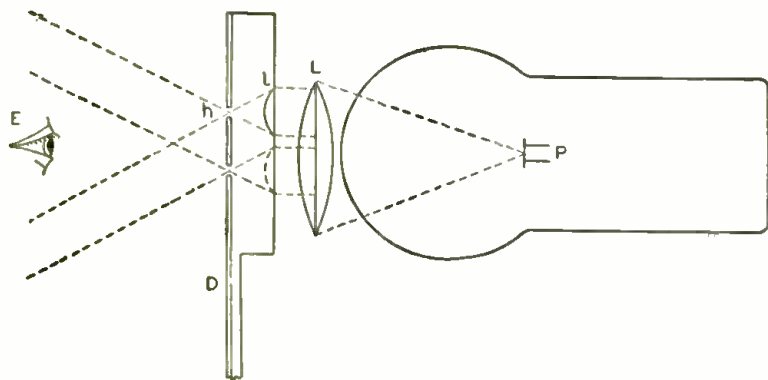

Fig. 4—Section of receiver scanning disc with lens system for utilizing small area light source.

change called for was the substitution of achromatic prisms, corrected for deep red and blue light, in order to prevent the scanning beam from breaking effectively into two beams for large angles of deviation. The problem of general illumination of the booth is principally the choice of a color of light which shall affect neither the potassium nor the caesium cells. For this purpose, a monochromatic yellow-green was chosen, secured by covering all the lights with a combination of orange and signal green glasses. The potassium cells are insensitive to this color of light, and the caesium cells were rendered so by placing over them, windows covered with a deep purple gelatin. This choice of illumination color made possible a satisfactory general level of illumination of the booth and the surroundings of the image without introducing spurious signals.

The transmissions of the purple filters, the response curves of the potassium and caesium oxide cells, the radiation curve of the incandescent lamps used for the scanning beam, and the transmission curves of the glasses used over the lamps for general illumination, are shown in Fig. 3. Comparing these with the response curve of the eye, also shown in the same figure, it will be evident how the general problem of securing photoelectric signals of maximum efficiency without interfering with the general quality of the image, or desirable conditions of illumination, has been secured.

Before going on to describe some of the optical features at the receiving end, we may pause to discuss the improvements in the television signal which have been introduced by the

changes just described. There is, of course, a substantial gain in the steadiness of the image due to the elimination of the arc lamps, much of whose effective radiation was from the arc stream which always wanders somewhat. The chief gain, however, is in the tone quality of the image of the face. The difference is very clearly shown if shutters are arranged so that either the potassium or the caesium cells may be used alone, alternately, and can then be quickly exposed together. With the potassium cells alone, as already noted, flesh tints are in general too dark, and tanned or ruddy complexions show unnatural contrast with the whites. Highlights due to reflection on the skin are often observed to be out of scale, with a resultant effect of mottling of the skin. With the caesium cells alone, on the other hand, the flesh tints are in general too light, and faces are apt to appear very flat. These differences were anticipated, but others not so obviously to be expected, have been observed. For instance, with the caesium cells, the pupil and iris of the eye are brought out with rather startling blackness, while with the potassium cells, the detail around the eyes is apt to be lost. The most satisfactory results are obtained with both sets of cells acting, for, as was hoped, the combination of the two ends of the spectrum, gives, in the case of the face, an effect very like that which light from the middle of the visible spectrum would give, that is, an "orthochromatic" image, as it would be described in photography, while the definition of important points, such as the eyes, is distinctly improved.

Passing now to the receiving end of the two-way television apparatus we recall that in the apparatus as originally set up and described, a simple disc with a spiral of holes was used, immediately behind which was a neon lamp with a large flat water-cooled electrode. On continued operation, it was found that the heavy current demanded in these lamps, in order to secure an image of sufficient brightness, caused rapid sputtering on the closely adjacent glass wall, necessitating frequent renewals of lamps. A very radical change in the disc and lamp design has been made by which this undesirable situation has been remedied.

The change in the disc consists in substituting for the simple Nipkow disc, with its spiral of holes, an alternative form, suggested also by Nipkow, in which each disc hole has associated with it a condensing lens, positioned so as to focus, in combination with a fixed collimating lens, and image of the source on the disc hole. The optical arrangement is shown in Fig. 4, and a photograph of the disc with lenses and lamp in place in Fig. 5. Referring to Fig. 4, *D* represents in section the simple disc with a spiral of holes, *h*; *l* represents a small

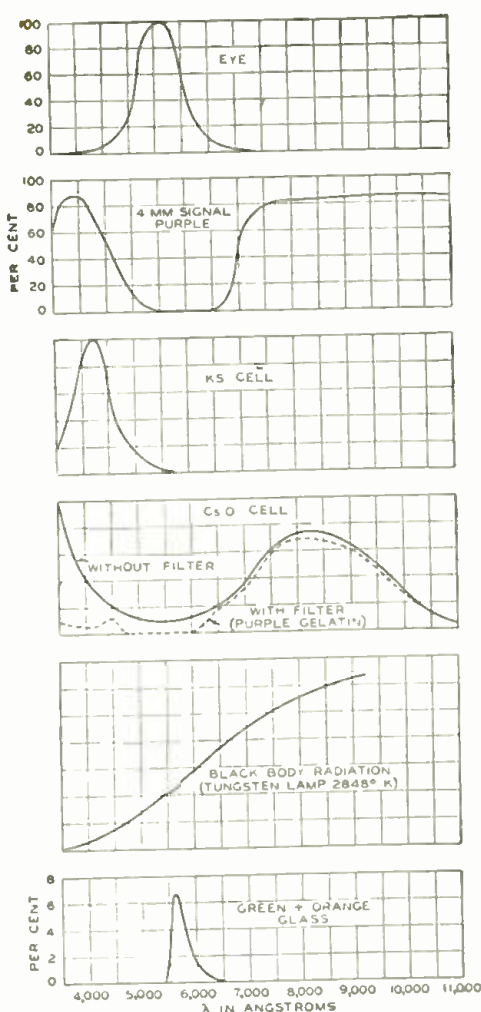

Fig. 3—Spectral characteristics of the scanning, viewing and illumination elements in two-way television system.

short focus lens, fixed in position with respect to *h* at a distance equal to its focal length; *L* represents a fixed lens of diameter large enough to cover the entire frame of the picture and the lenses *l*; *P* represents the glow lamp electrode. A great advantage of this optical arrangement is that the cathode of the glow lamp can be made quite small, and can be removed, as shown, to a considerable distance from the glass wall of the containing tube. In consequence of these changes in lamp design, a very high current density can be obtained for a relatively low expenditure of energy, with at the same time a long lamp life.

The condenser lens disc is observed exactly as the simple disc, by the eye placed at *E*. According to Nipkow, when lenses are used on the disc, the holes should be covered with diffusing material. This is not necessary in the present case, because in the two-way booth, the observer has very little latitude of motion, and it is only necessary that his eyes lie in the overlapping cones of rays from the extreme holes in the field. By making the lenses *l* of large diameter compared with their focal length, the solid angle through which an image is visible is entirely adequate.

### New Hartman Scanner

HERE is a scanning unit that deserves special merit, inasmuch as picture framing difficulties are easily eliminated. Due to the 24 inch aluminum disc large and brilliant pictures can be obtained. The scanner is of the conventional vertical disc type mounted on a rigid cast-iron support and driven by a 1/6 H.P. synchronous motor. Belt drive is used as a matter of quietness and flexibility. Noise is practically eliminated, only the slight hum of the AC motor being heard. The thin, hard aluminum disc runs perfectly true and is accurately punched with the required number of "square" apertures on a precision indexing machine, which was especially built for this work.

The cast iron mounting bracket supports the lens, neon lamp, scanning disc and speed control. Large bronze, wool-packed, bearings are used, insuring long service.

The 2 pulleys are so accurately machined that it is only necessary to plug the cord into any 110-120 V-60 cycle A.C. line and the picture is immediately framed. Any tendency of the picture to "float" can be easily corrected by adjusting the "speed control" either to the right or left.

The makers recommend use of a synchronous motor but gratifying results can be attained with the regular induction type motors. A three inch ground lens is regularly supplied which enlarges the picture to 3 x 3 inches. Further magnification can be attained by the use of an additional lens. The apparatus comes mounted on a solid wood base cushioned with sponge rubber and can easily be fitted into most any console type radio cabinet or Victrola cabinet.

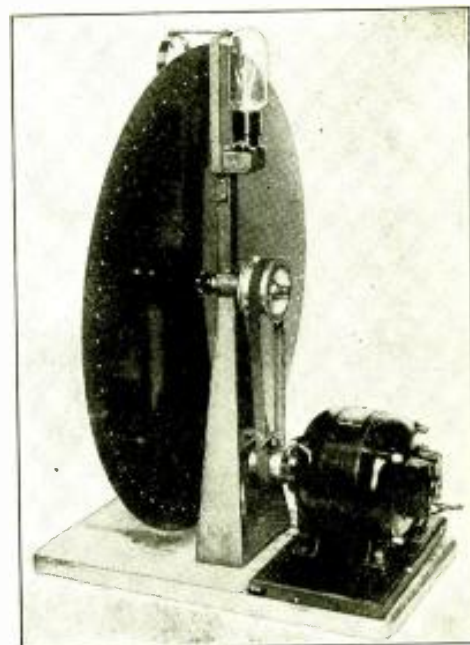

The Hartman scanner has special constant speed regulator, 24-inch disc with square holes, with 3-inch lens.

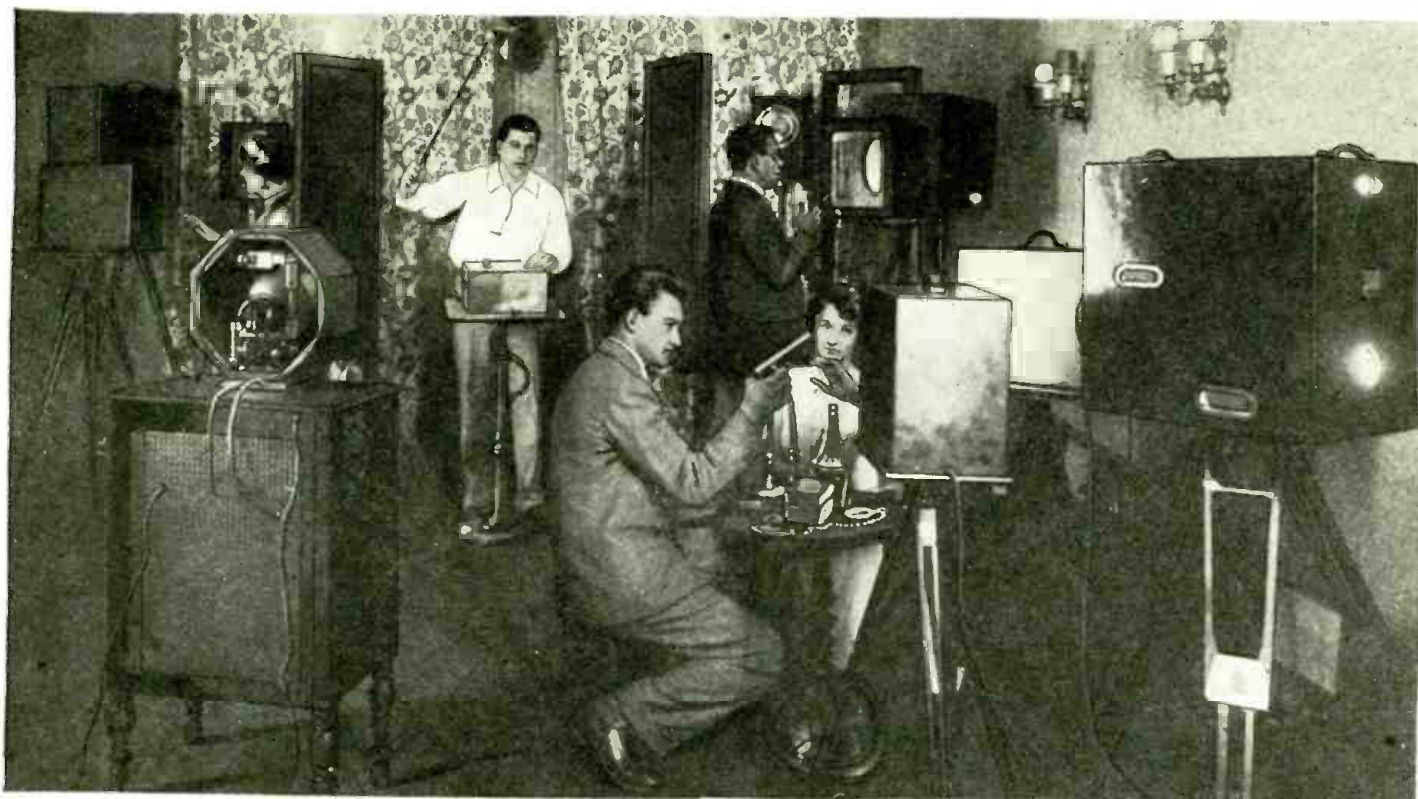

The arrangement of the three televisors is shown above. The director is seen at his selector box as the "doubles" do their bit with an army revolver. The different images were faded in and out by the director.

# How We Staged the WORLD'S FIRST *Television Plays*

By WILLIAM  
J. TONESKI

**The First Television Broadcast**  
**"R**EADY . . . Go ahead," after a brief pause the microphone switch was pressed and a voice announced the beginning of the world's premier *Television drama*, which was broadcast from the studio of the General Electric Company's station "WGY," at Schenectady, New York, on the afternoon of September 11, 1928.

When the curtain rose in this first theatre of the air the audience "saw" as well as "heard" the key turning in the lock and the door opening on the initial scene of a play entitled "*The Queen's Messenger*," which was written some thirty years ago by J. Hartley Manners.

As the play went on, the heads of the two characters appeared in the pink field behind the four-inch lens of the television receiver, while their voices issued from the loud speaker

below. When the action became more intense, the faces were "faded-out" in a true movie fashion and pantomime was again introduced; the hands of the two characters appeared—sometimes there was a cigar in the man's hand and a cigarette in the lady's; then again the hands picked up champagne glasses, filled them, and after the wine glasses tinkled lightly when touched, they disappeared only to reappear suddenly at the lips of the two actors.

### What the Audience Did Not See

What the audience did not see, however, was the elaborate preparation that was required for the staging of this short television play. Without taking into consideration the days of tedious engineering work which was essential for the proper installation and adjustment of the equipment, there was the problem of evolving an entirely new "studio technique."

As soon as we were informed about our assignments, the two actors and their "doubles" were handed manuscripts of the play and the line rehearsals commenced. From the very beginning we ran into difficulties; because of their newness the photoelectric cells, the "scanning machines" or "cameras" and the "monitor" were merely "this box" or "that box." Gradually, by a process of elimination, we finally reached a point where the same name was used by all the people in the studio.

### Actors Get Used to Being "Scanned"

Difficulty was also experienced when the actors were placed before the flickering light produced by the rotation of the scanning disc. Not only was this flicker distracting at first, but also slight headaches resulted; and the actors, though equally experienced before microphone and footlights, found it difficult to remember their

THREE years ago the world's first two television plays were staged in the studio of the General Electric station—"WGY," at Schenectady, New York. We are now on the threshold of commercial television and ere long, the television studio directors and stage managers will be pondering the problems which first occupied the minds of those who successfully staged the first television plays at "WGY." Not only were entirely different "make-up" colors than those used for ordinary stage productions found necessary, but as Mr. Toneski points out, careful study and a lot of experimenting had to be done; so that the various "props" such as guns, lamps, jewelry, etcetera, would "pick up" well and reproduce clearly on the television screen. The fading "in" and "out" of the images of the various actors and "props" were successfully accomplished, as here explained by Mr. Toneski.



Right — The photograph shown here portrays Gismonda and Pietro in a scene from Part 2 of the second Television drama "Torches"; this part was presented with 60 x 72 picture elements.

lines. In addition the televised person had to keep his head "in focus"; because the lens of the scanning machine concentrated the beam of light at a certain distance from the camera. If the head was turned in either direction, or moved forward or backward, the focus was lost and the lines became blurred.

**Studio Problems We Had to Solve**

Not only did we have trouble with the focusing, but in addition back-

that, for example, the "Hairy Ape" in Eugene O'Neil's play of the same name can no longer be some wizened little man with a hoarse voice, who could have played this part without any difficulty in front of the microphone.

The same situation comes up in the use of properties. The microphone can keep many secrets, because it never divulges that a galloping horse is in reality a stick beating a pillow, or a forest fire is a blow-torch used in conjunction with a match box which is slowly being crushed between the fingers. No longer will the leading man stand five yards away from his lady love and kiss her, as he did in the

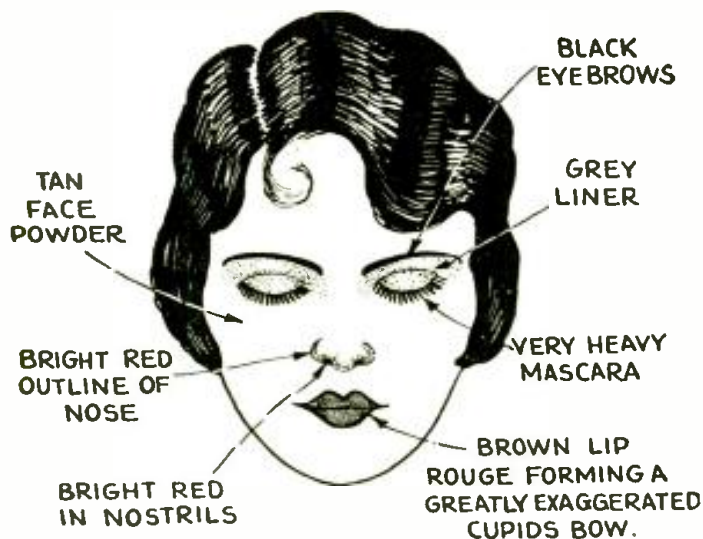

Sketch "B," at left, illustrates how the different colors were used in "making up" the characters for the first television play, as here described in an interesting manner by Mr. Toneski, who acted as stage manager for the first television players.

grounds had to be devised, properties furnished, and a new make-up invented. Of course, with further enlargement of the image in the future, the background became the scenery while costumes supplemented the make-up. The portrayal of characters in television plays is necessarily different from the method used in broadcasting, because with the appearance of the actor before the audience, make-up must be used and in addition casting for "types" must be inaugurated. Even though, because of technical limitations, we had no such problem in the first broadcast, one can easily see

Sketch "A," at the right, shows the studio's arrangement when the world's first television play was produced in the studio of the General Electric station "WGY," at Schenectady, N. Y. This plan shows the arrangement of the three television "pickup cameras" during this epoch-marking television broadcast. The director was so placed that he was in a position to see the three cameras at all times, and he could also fade the various images "in" or "out."

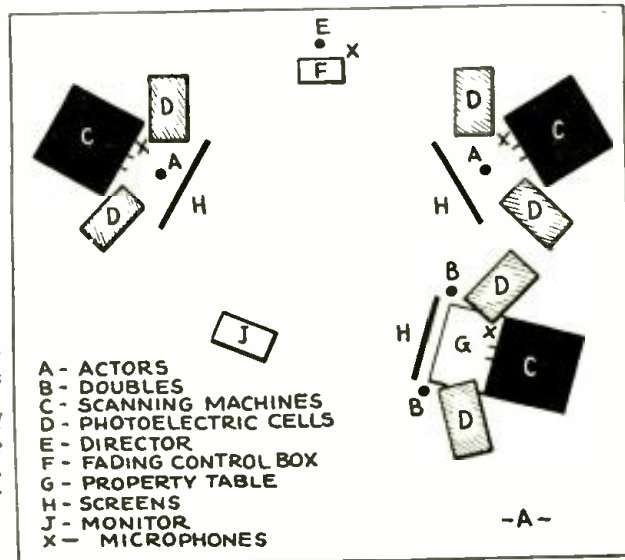

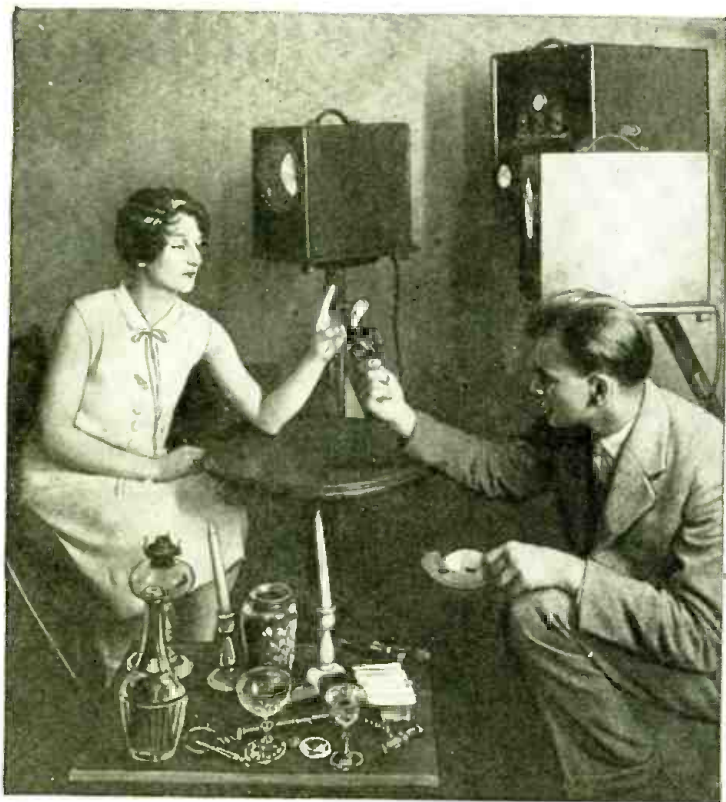

Possibly you think that staging a television play is about the same as producing any other play, but as Mr. Toneski, who assisted in the production of the first television plays explains, special colors for the actors' make-up had to be found, and special study had to be given to the color and nature of all "props" used in staging the television plays.

*The photo shows the "doubles" sitting at the "prop" table. Note the various objects used as properties in the first broadcast.*

radio dramas of the pre-television days.

#### Color of Background

Even though the size of the televised surface in the first broadcast measured only 12 x 12 inches, backgrounds had to be employed. At first we tried a plain mahogany stained wooden frame, which was placed about a foot behind the actor. This offered no contrast; so cardboard painted with different colors was tried. It was discovered that a dull gray color offered more contrast than any other.

#### Keeping the Actors in Focus

In order to keep the actors in range, their hands were placed on the back of a chair, which was located at the proper distance from the lens. As soon as the head was moved either forward or backward, it was again out of focus. A frame resembling a small window was finally devised; one of these is shown directly in front of the male character. This frame is about 18 inches square, and so arranged that it can slide up and down like a window. This adjustment is provided to adapt it for actors of different heights. Even with this arrangement, the actor's head was free and, upon being tilted either backward or forward, it was out of focus.

As time went on all the characters became accustomed to the restricted field of action and by placing them within reach of the director's wand, as shown in Fig. A, it was found that they would usually adjust their positions upon receiving a light tap on the shoulder. If difficulty was still experienced, the director "faded-in" the other actor, until the first regained his, or her position.

#### The Use of "Fade-Outs"

The "fade-out" and "fade-in" of characters was entirely controlled by the director, who watched the performance in the monitor shown in Fig. A. By turning a small knob, the image in the receiver was made to "fade-in," in exactly the same way that it does on the motion-picture screen. The selector switch was so ar-

ranged that it could pick up any of the three cameras with equal ease. The use of "fading" contributed greatly to the success of the first broadcast; because it not only added to the variety, but also enabled the director to impress certain things upon the audience by suggestion. For example, when the messenger spoke of Russia's Imperialism, a huge Russian bear was "faded-in," and when the lady spoke to the messenger about the dangers that confronted him on his mission, an evil-looking dagger slowly moved across the screen, then a revolver followed, and finally a sinister face appeared.

In order to use the "fade-out" effectively three sets of equipment were required. One camera with two photoelectric cells was for the leading lady, a similar set was for the leading man, and a third set had to be used for the "doubles" and "properties." (The name double was assigned to the two people whose hands performed the actions of the actors.) Fig. A pictorially presents the arrangement of the equipment in the studio.

Drinking wine was a very complicated procedure, in the first broadcast. We first arranged to show the hands of the doubles, as they picked up the bottle and poured the wine into the glasses. Then the director switched to the actors as a toast was offered, finally the *properties camera* was again used to show the glasses as they touched lightly and began to rise slowly toward the lips of the characters. The last picture showed the ac-



*The first scene, taken from Part 1, shows all the characters as they appeared to the audience in the drama "Torches." This section of the play was presented with 48 x 48 picture elements.*

tors drinking the wine, which the doubles had poured. In order to follow this plan effectively, duplicate sets of properties were placed on a stand alongside each actor.

**Choice of Properties**

The choice of properties which could be recognized by the audience, required a great deal of patience. After trying many different kinds, we found that the rose-colored wine glasses were best adapted for the television camera. All kinds of shining articles (such as rings with stones, and mirrors, etc.) had to be avoided because, when the reflected light reached the photo-electric cell, one line across the entire width of the image became blank. The choice of a watch presented a problem. It was found that the average watch reflected too much light; so toy imitation timepieces were tried. Since these also in no way resembled a watch, various drawings were made and placed before the camera. After many trials, a piece of gray cardboard with notched edges, roughly resembling the teeth of a gear, produced the best picture. The hours were painted on with black india ink. Finally, the watch was attached to a chain consisting of half-inch iron links!

**Facial Make-Up**

In addition to the backgrounds, and properties, we were confronted with the task of inventing a new *facial make-up!* When rehearsals first began, we noticed that moving the head in any direction, or even laughing or smiling in front of the camera caused a shadow which changed the appearance of the actor at the receiving end. Make-up had to overcome this effect by making prominent all the parts of the face which were thrown into a shadow at any time. Hours were spent in applying and removing all kinds of powders, creams, and grease paints. Only because of the great patience of the ladies who took part in the produc-

**MR. TONESKI**, the author of this article, appears in the role of a "double" in the photos showing scenes from the first Television drama, "The Queen's Messenger." Mr. Toneski has been interested in radio since 1917, and when broadcasting became popular he became the "property man" for the WGY players. For over a year he served in this capacity, producing sound effects for the regular studio players as well as the student group. Later Mr. Toneski became stage manager.

*This dramatic incident is taken from Part 3 which was shown with 80 x 80 picture elements.*



tion, did we finally develop a make-up which was a combination of that used on the stage and the screen. Fig. B shows the different colors that were used and how they were applied.

**Brown Lipstick Better Than Red**

The usual cold cream was covered with grease paint, applied with wet hands. Following this a black pencil was applied to the eyebrows, a gray line to the eyelids, and heavy beads of mascara to the lashes. We also found that brown lipstick instead of the conventional red was much more effective; this was painted on in the form of a greatly exaggerated Cupid's bow. Rouge was not essential, but a tan powder had to be applied to the face. The nose and even the inside of the nostrils were lined with a bright red rouge. The combination of gray eye-

lids, brown lipsticked nostrils and tan powder created a truly weird effect when the actor was seen in daylight; but through the televisor the face looked perfectly natural, and the distortion of the features resulting from laughing or smiling was now entirely eliminated.

As a final touch the messenger wore a blue collar, while the lady wore a crown in her hair. All the jewels were removed from the crown in order that no light could be reflected.

**The Presentation of the Play**

When the signal sounded for the beginning of the play, the two actors stood at their cameras, while the doubles had either their hands or else some "prop" in the frame. This was done in order that the director might be able to switch to any one of the other two machines, as soon as one character got out of focus. The play was presented in a darkened room, and the positions of all the properties had to be accurately learned, so that the correct "prop" could be introduced at the proper cue. Even though the play could have been produced in daylight, a darkened room was preferred; since it not only enabled the director to watch the performance in the monitor, but it also assisted the actors to remain in focus by enabling them to see the scanning lines.

"The Queen's Messenger" was also presented on the evening of the same day, and reports of its reception came from amateurs from as far west as the Pacific Coast.

*(Continued on page 315)*

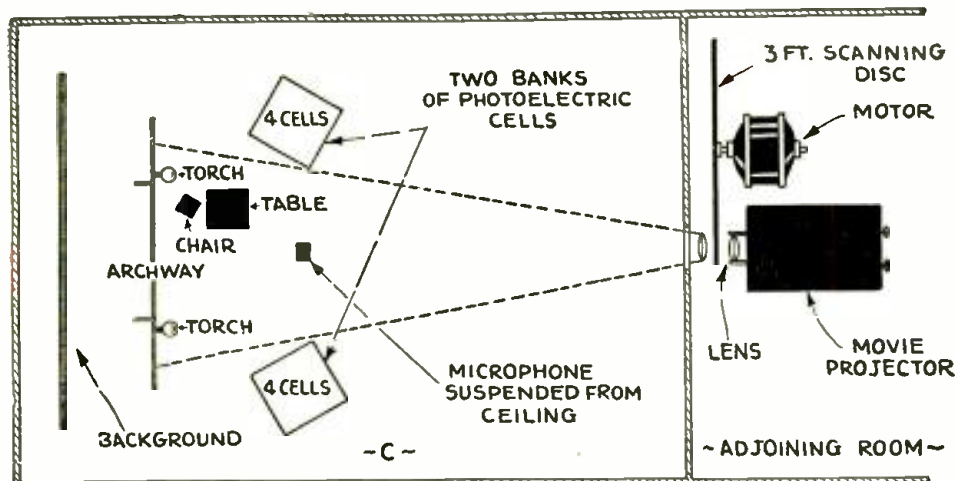

Sketch "C." above, shows the studio floor plan and arrangement of the photo-cells, with "flying spot" projector, used in broadcasting the second television drama, "Torches."

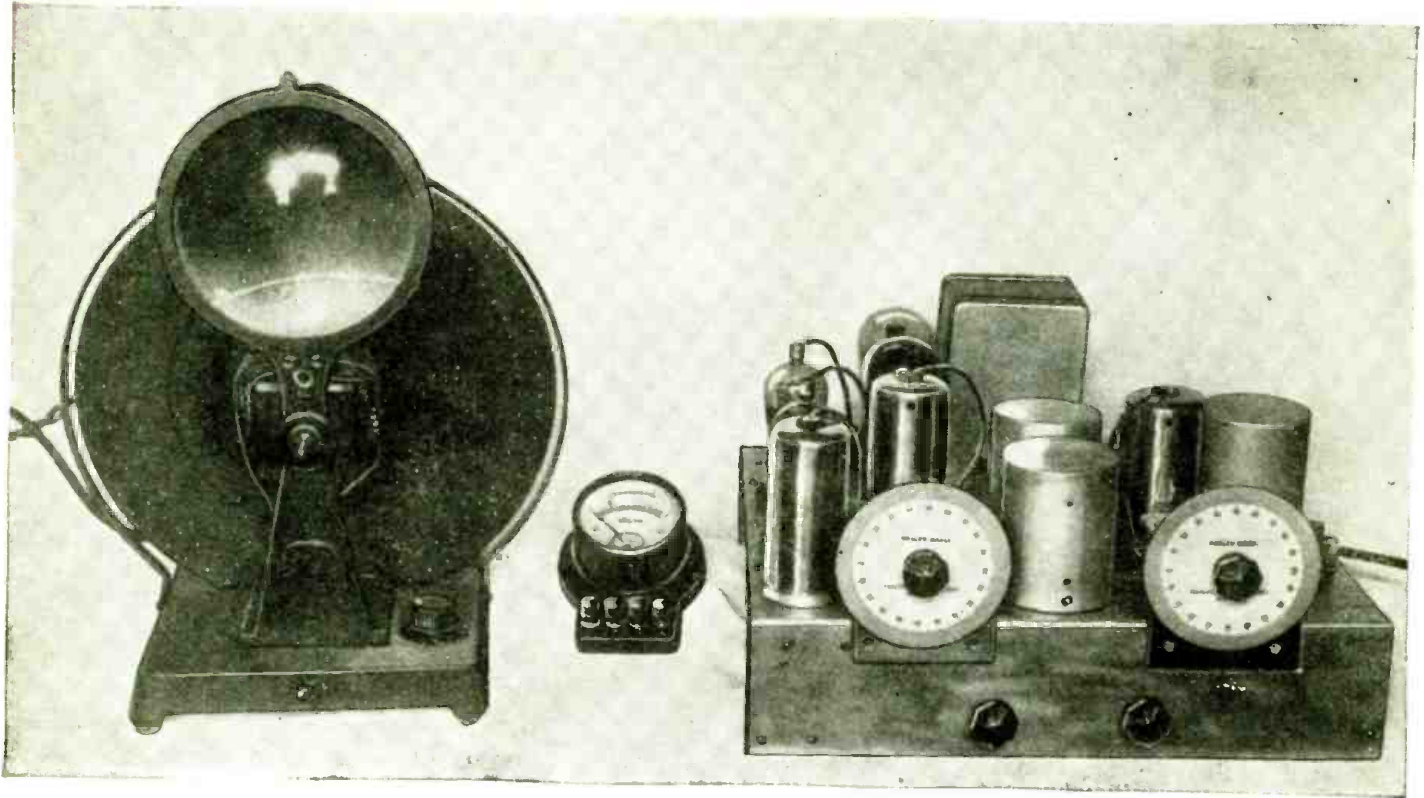

Excellent appearance of the television receiving outfit here described, which includes a "scanner", "tuner" and "amplifier".

# The "FIND-ALL" Television Receiver

## *Details of Assembly, Wiring and Operation*

By H. G. CISIN, M.E.

**T**HE construction of the "Find-All" television receiver should present no difficulties to the average set builder. In fact, it is easier to assemble than most broadcast receivers. As outlined in the previous issue of TELEVISION NEWS, the purpose in presenting this circuit to set builders has been to furnish them with a complete television receiver, of ultra-modern design, which they can construct out of standard, nationally-available parts.

For the fan who wishes to dabble in television, but whose finances are somewhat limited, this receiver obviates the necessity for the outlay required for a complete receiver kit, permitting instead the purchase of separate parts as funds become available. Although this procedure may take a little more time, the final results will be well worth waiting for.

Through the use of a tuned antenna in this receiver, the voltage appearing across coil (4) is quite large. This very nearly gives the effect of adding another R.F. stage. An inspection of the schematic diagram reveals the fact that one of the filter chokes is tuned through the use of a condenser (68);

One of the features of this television "tuner" and "amplifier" is the fact that all of the parts are accurately specified and furthermore they are all standard parts that can be purchased on the open market. You can use this receiver to tune in television image signals, then connect the output to your own "home-made scanner" or the one specified by the author.

so that it offers a high impedance to the 120 cycle output. Hence the line hum, or ripple, cannot cause interference. In the original receiver, a condenser having a capacity of 0.1-mf. was found to give best results. However, variations in the filter choke (69) may require the use of a higher or a lower capacity condenser. The exact value of this can best be determined by trial.

The receiver is designed to tune over the 100- to 150-meter wave band. Adequate picture detail is obtained

through the use of a special R.F. (radio frequency) amplifier, passing a band of from 30 to 40 kilocycles. This separates the stations and at the same time amplifies the side bands as well as the carrier frequencies. The audio amplifier is worked out to give a flat amplification characteristic from 15 to 40,000 kilocycles.

### Constructional Details

A No. 12 gauge aluminum sheet, 15" x 19", is bent with two right-angle bends, as shown in the illustration, to form a chassis, 12" x 15" x 3½" high. Socket holes and holes for the electrolytic condensers are then spotted and drilled. A square hole is cut at the rear of the chassis, for mounting the power supply transformer. The positions of the various fixed Aerovox condensers beneath the chassis are located and mounting holes are drilled. Mounting holes are also drilled for switch (73) and volume control (8).

The 8 wafer-type sockets are mounted as shown, first fastening the shield bases for (5), (16) and (29). The four binding posts are also mounted at this time. All posts are insulated



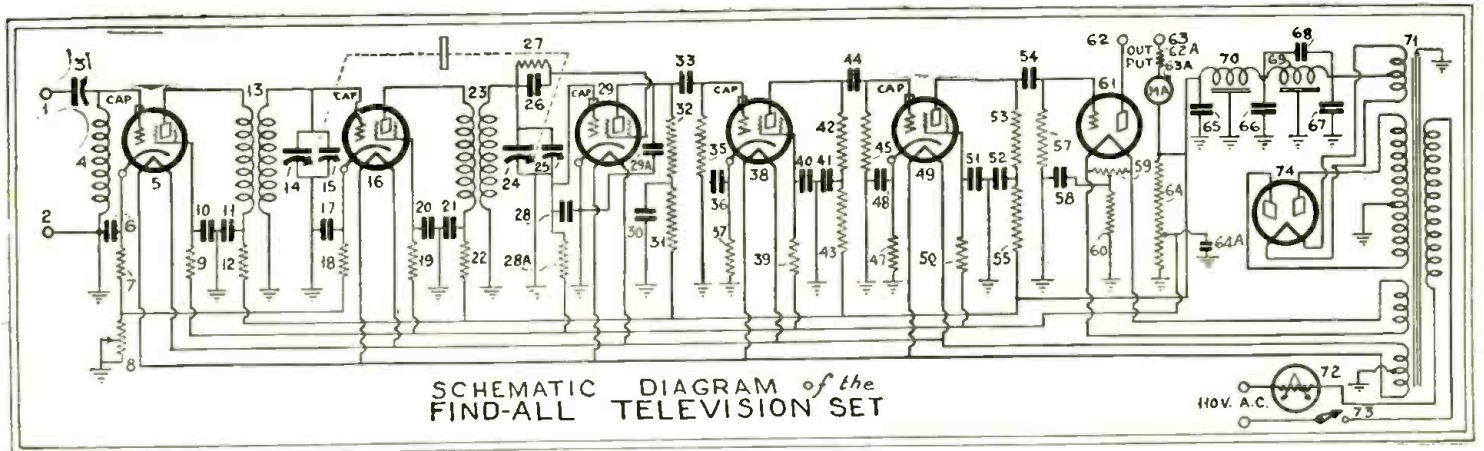

Hook-up of apparatus and tubes used in the "Find-All" television receiving set here described with complete specifications.

from the chassis, except ground post (2). An aluminum mounting plate 3½" wide by 3" high is cut for the dual Cardwell condenser (14, 24), while a composition mounting plate of the same size is cut for condenser (3), since this condenser must be carefully insulated from the chassis. The mounting plates are fastened to the front of the chassis as shown, and the condensers are mounted on them.

The double choke (69, 70) and the Acra-test power supply transformer (71) are mounted at the rear, as indicated in the top view. The chassis is then turned upside down and the various fixed condensers, including the three electrolytics are mounted. The small Varitrics (15, 25) are then mounted and finally the Truvolt resistors (64), (60) and (62A). These are insulated from the chassis by mica insulators. The Durham resistors and the flexible wire resistors are soldered into place during the process of wiring.

The power switch (73) and the volume control (8) are mounted on the front of the chassis, which is then

turned right-side up. The three Find-All television coils are mounted next, using three small right-angle brackets.

### Ready for Wiring

The receiver is now ready for wiring. Filament circuits are wired first, twisting the various pairs of leads. Grid circuits are wired next. Screen grid (double grid) connections are all made at the socket terminals marked "G". Note that the double grid of the space-charge detector (29) connects to the grid leak and condenser.

Plate circuits are wired and then cathodes. Then the wiring to all bypass condensers is completed. Condenser (29A) should not be necessary under ordinary circumstances. Bias resistor (60) is wired in, using either the center tap on the transformer or else a 20-ohm center-tap resistor as shown at (59). The wiring to volume control (8) is finished. The power supply transformer, double choke, electrolytic condensers, voltage divider and rectifier tube are then wired in; also the Amperite socket (72), and switch (73) are wired in series with

the primary of the power transformer.

It will be noted that the diagrams and list of parts in this article have been changed slightly from those shown in the previous article. Additional experiments with the receiver indicated the advisability of making these revisions, and hence the new diagram published herewith should be followed. The changes consist in the addition of a 3,000-ohm resistor at (62A) to control current flow in the neon lamp. At (65) the capacity has been increased to 16 mf. while at (41), a 4-mf. condenser is recommended. Another 4-mf. condenser has been added at (64A). It was also found possible to dispense with resistors (34), (46) and (56).

All wiring is done with Corwico Braidite beneath the chassis. If hum is still noticeable in testing the set on a loudspeaker, it may be necessary to change the value of condenser (68) for best filtering action. A suitable switch should be provided for changing from speaker to neon lamp. The characteristic television signal is tuned in on the speaker, adjusting the equalizing

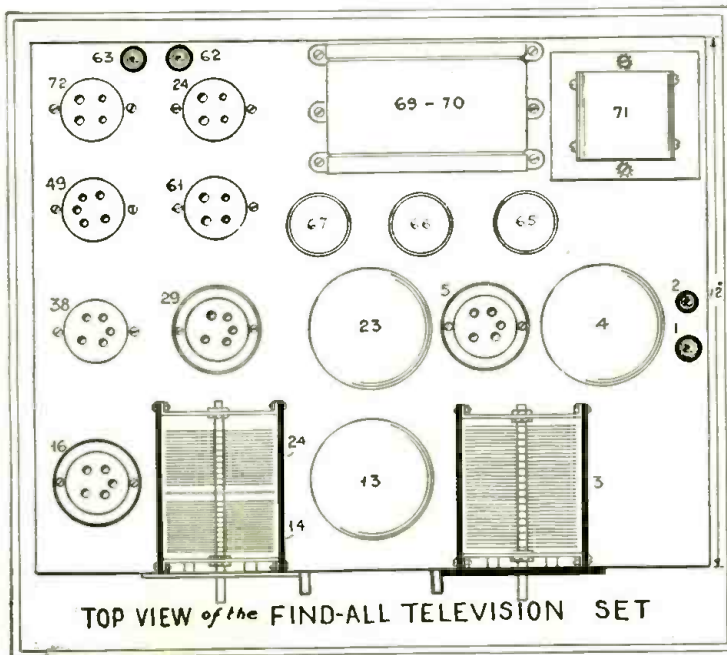

Top view of "Find-All" television receiver with parts numbered.

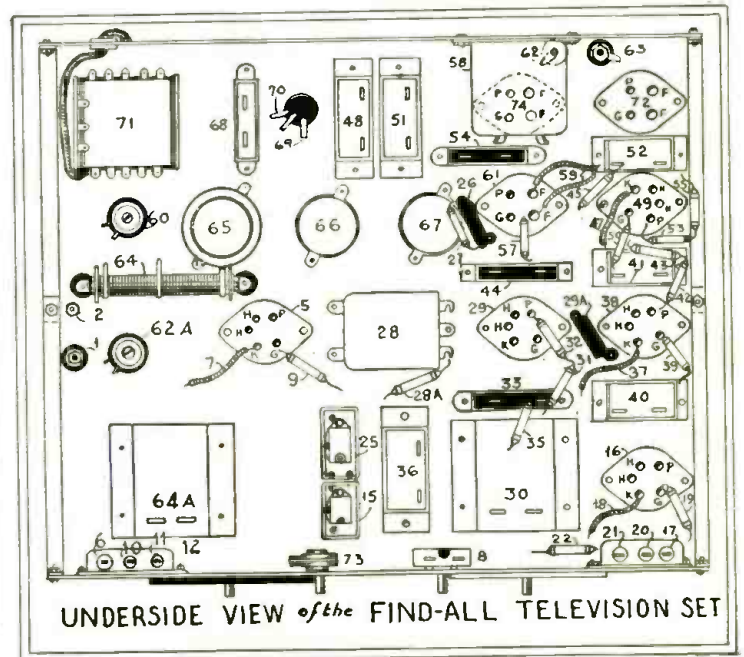

Neatly arranged under-side of the television receiver.

condensers (15) and (25) for maximum volume. The neon lamp is then substituted. The resistance at (62A) may be reduced until the current to the neon lamp is about 20 mils, as indicated on the Weston milliammeter. This should be kept in the plate circuit of the power tube at all times, to indicate any overloading.

Stronger signals can be obtained by connecting a .0001-mf. condenser between the plate of the detector tube and ground.

**Complete List of Parts Required for the Find-All Television Receiver**

- 1—.000365-mfd. Cardwell "Midway" Variable Condenser, type 407-C (3).
- 1—.0002-mfd. (each section) Dual Cardwell "Midway" Variable Condenser, type "C", (14, 24).
- 2—De-Jur-Amsco Single Varitors, 140-mf. maximum, type X-71 (15, 25).
- 1—Electrad Volume Control, type RI-202 (8).
- 1—Electrad Truvolt Fixed Resistor, type B-15 (60).
- 1—Electrad Truvolt Fixed Resistor, type B-30 (62A).
- 4—1,000 ohm Electrad Truvolt Flexible Wire Grid Resistors, type 2G-1000 (7, 18, 37, 47).
- 1—Electrad Truvolt Fixed Resistor Voltage Divider, type C-200, with extra tap (64).
- 1—Electrad Truvolt Type V-20 Center Tap Resistor (Optional) (59).
- 1—Power Switch (73).
- 1—.0001-mf. Aerovox Fixed Mica Condenser, type 1460 (26).
- 1—0.1-mf. Aerovox Fixed Condenser, type 207 (68).
- 1—.001-mf. Aerovox Fixed Mica Condenser, type 1460 (optional) (29A).
- 3—0.25-mf. Aerovox Fixed Condensers, type 207 (33, 44, 54).
- 1—1-mf. Aerovox Fixed Condenser, type 261 (28).
- 6—2-mf. Aerovox Fixed Condensers, type 207 (36, 40, 48, 51, 52, 58).
- 2—0.1-mf. (each section) Triple Section,

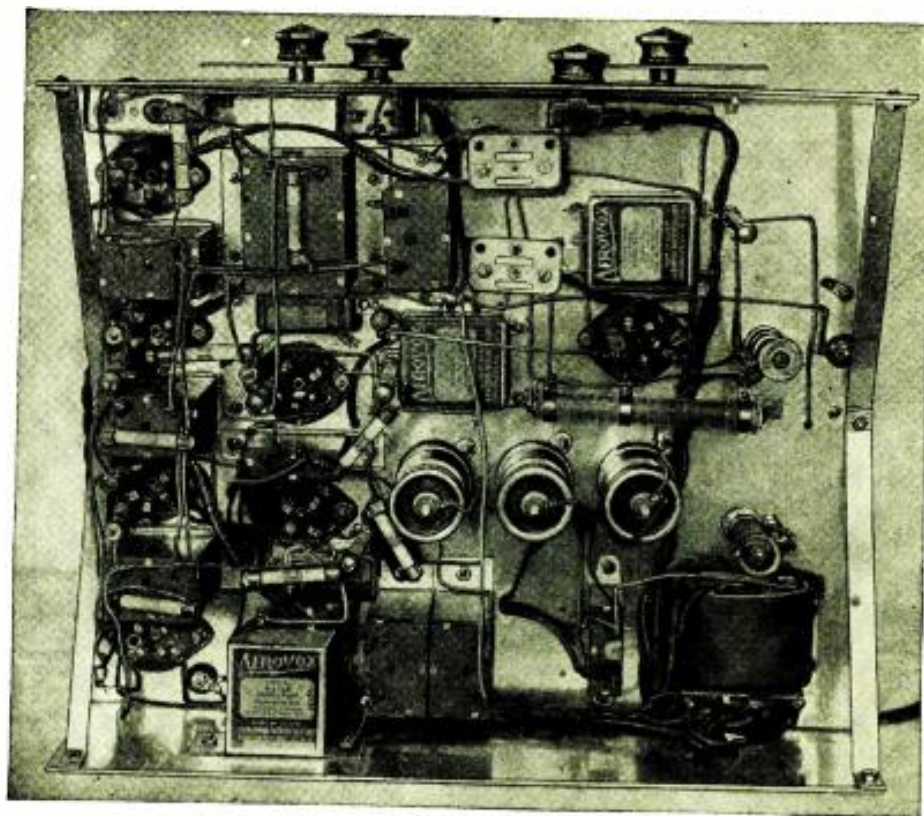

*This photograph shows neat layout and wiring job on the "Find-All" television receiver as built by the author.*

- Metal Case Aerovox Condensers, type 461-31 (6, 10, 11) and (17, 20, 21).
- 2—8-mf. Aerovox Hi-Farad Dry Electrolytic Condensers, type G5-8 (66, 67).
- 1—16-mf. Aerovox Hi-Farad Dry Electrolytic Condensers, type G5-88 (65).
- 2—4-mf. Aerovox Fixed By-Pass Condensers, type 207 (30, 41).
- 8—50,000-ohm Durham Metallized Resistor Powerohms, with Pigtail Connectors, type MF-4 (9, 19, 28A) (32, 39, 42, 50, 53).
- (NOTE: Resistors (34, 46, 56) are omitted in revised diagram; these are not needed.)
- 1—4-mf. Aerovox Fixed By-Pass Condenser, type 207 or G5-4 (64A).
- 3—25,000-ohm Durham Metallized Resistor Powerohms, with Pigtail Connectors, type MF-4 (31, 43, 55).
- 1—50,000-ohm Durham Metallized Resistor Grid Leak, with Pigtail Connector (27).
- 2—75,000-ohm Durham Metallized Resistor Powerohms, with Pigtail Connectors (12, 22), type MF-4.
- 3—250,000-ohm Durham Metallized Resistor Powerohms, type MF-4 (33, 45, 57).
- 1—Find-All Shielded Television Antenna R.F. Inductance Coil (4).
- 2—Find-All Shielded Television R.F. Transformers (13, 23).

*(Continued on page 316)*

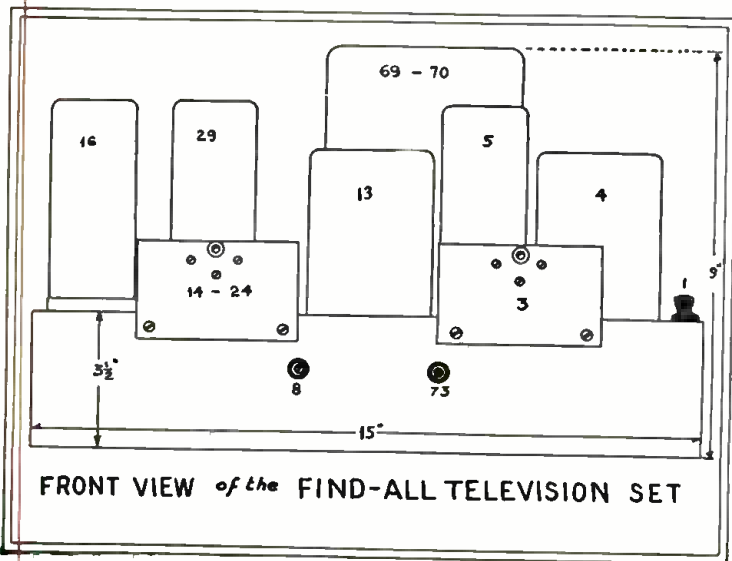

*Front view of the "Find-All" television receiver.*

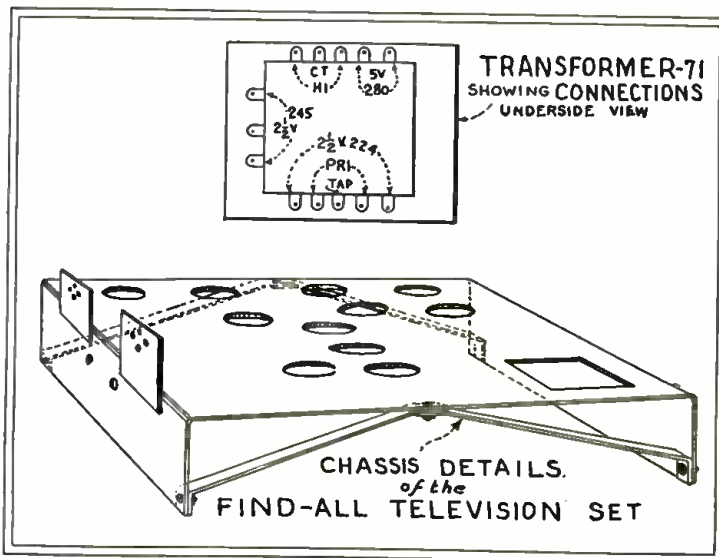

*Design of metal chassis, also transformer connections.*

# DETECTION in Television Receivers

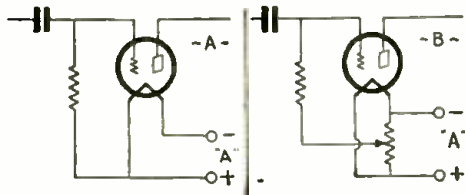

Fig. 1—"A"—Usual vacuum tube detector hook-up with grid rectification; "B"—control of grid bias with potentiometer.

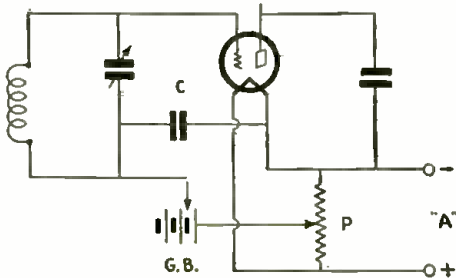

Fig. 2—Plate rectification detector circuit with fine control of grid bias by means of battery and potentiometer.

IN television receivers, there is generally used a detector with regeneration or plate rectification. That these systems of detecting the radio-frequency oscillations received are not the only solutions, however, is apparent from a study by W. J. Richardson in the periodical "Television," to which we are indebted for what follows:

Fig. 1 shows the usual audion (vacuum-tube) hook-up. In the case of "A," the detection is caused by the charge on the grid. This hook-up has worked very well for voice, to be sure; but it does not give very good pictures in the case of television. An important improvement can be attained by using, instead of the usual 300 mmf. grid condenser, one of 200 or 150 mmf., and increasing the resistance of the grid leak from 2 to 4 megohms to make up for this. It is, furthermore, advisable to adjust the grid bias carefully; this being best accomplished with the use of a potentiometer, as shown in Fig. 1-"B."

A further disadvantage of the grid-leak detector for the purpose in question is evident from the following consideration: it is well known that in a television receiver, there must always be a very definite number of stages of amplification; since the picture received is "reversed" after every stage, so that from a positive picture comes a negative, etc. For this reason a resistance-coupled amplifier, in connection with this type of detector, must have either two or four stages. But two stages are generally not enough, and four stages are too many. This is probably the main disadvantage of the grid-leak detector in television reception, and therefore, as a rule, plate rectification is preferred.

A hook-up advisable for this purpose is shown in Fig. 2. Since the grid return, for plate-circuit rectifica-

tion, is directly connected with the grid, without the use of a grid condenser, the grid leak can also be omitted. To be able to adjust carefully, to the lower bend of the plate-current characteristic curve, an exact adjustment of the bias of the grid circuit is necessary. For this the grid battery GB, consisting of a small number of cells, is used in connection with the potentiometer P, which effects the fine adjustment; while the blocking condenser C (of about 300 mmf. capacity) serves to prevent the high-frequency oscillations from going via battery and potentiometer. With this hook-up, the incoming signals are first amplified in the tube itself, before they are rectified; a process decidedly different from that in the grid-leak detector. Since the arrangement gives sufficiently great amplification, even to high-frequency signals of great energy, it operates free of distortion to a great extent.

Although plate rectification, therefore, is in practice fairly satisfactory, it is natural to look for other methods of detection, which may perhaps permit improving television reception. For this purpose Richardson has ex-

perimented with a simple two-electrode tube as rectifier; *i. e.*, without amplification within the tube. The ordinary two-electrode tube is certainly not suitable for this purpose since its characteristic line is strongly bent. Therefore Richardson used the hook-up shown in Fig. 3, invented by H. L. Kirke, which incorporates a three-element rectifying tube (R2). The grid is given a positive voltage, as regards the cathode, while the plate is given a low potential; with the result that the plate current, within a wide range follows a linear characteristic so that no distortion commences in the rectifying tube. But such a tube, of course, furnishes no amplification. For reception there is therefore required effective radio-frequency amplification, which is obtained in this hook-up, by the screen-grid tube R1; while the detector R2 is followed by three stages of audio frequency amplification.

In Kirke's hook-up, the potential on the grid of rectifier R2 is so regulated that the internal resistance of the tube is as low, and the plate characteristic as straight, as possible.

(Continued on page 307)

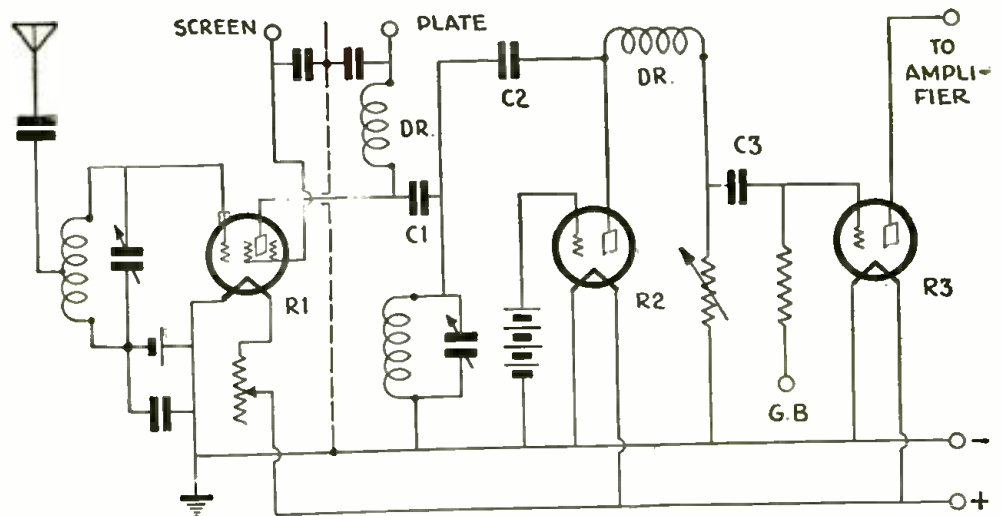
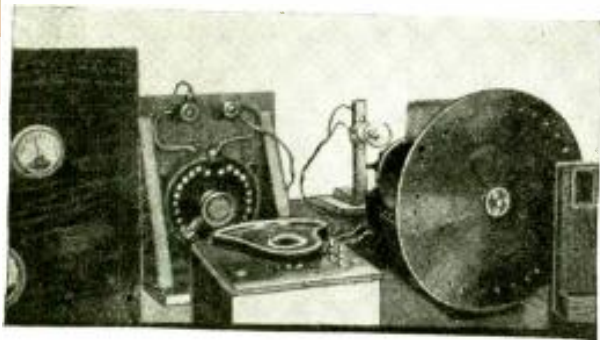

Fig. 3—Above, shows the Kirke circuit, which utilizes tube "R2" as a pure detector, without amplification, the grid being given a positive charge, with the result that the plate current follows a linear characteristic, with no distortion occurring in the rectifying tube.



Television receiver which picked up W3XK images in Kansas.

# How We Received W 3 X K Images in Kansas

By C. BRADNER BROWN

Construction data is given by Mr. Brown on the actual television receiver and scanner used at the University of Kansas, in successfully picking up the Jenkins television images from W3XK, Washington, D. C. A new feature is the "impedance" coupled amplifier.

Fig. 3—Set-up of television scanner, main driving motor "M", which can be of any standard type, together with phonic wheel synchronizing motor "F & G". "D" is the scanner disc mounted on a smaller disc of heavy aluminum, with counter-sunk rivets; "G" is a 48 or 60 tooth soft iron gear; "F" field coils; "S" tubular brass shaft, 3/8" diameter; "C" coupling of rubber tubing.

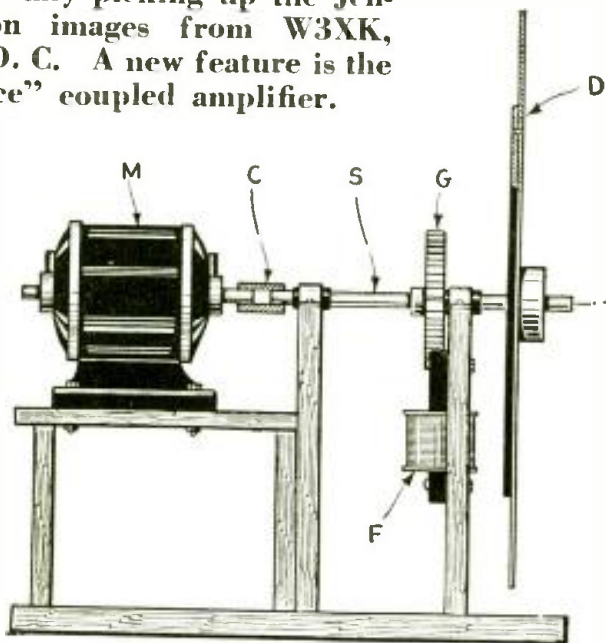

- SIDE VIEW -

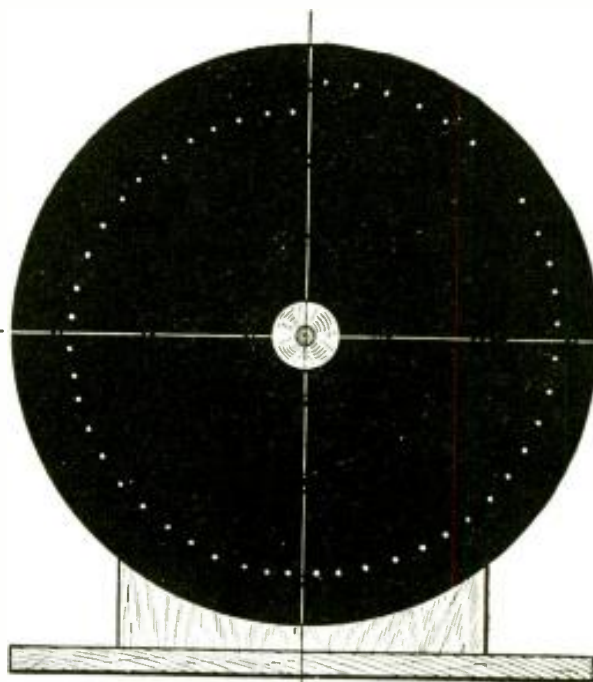

- FRONT VIEW -

FIG 3

As soon as the recent "engineering exposition" held at the University of Kansas was concluded last spring, the television demonstration set was dismantled; and the author set about building a set to receive the Jenkins signals from "W3XK" in Maryland.

The previous set had been a manually synchronized outfit, with a 900 R.P.M. induction motor, controlled by a choke coil in the A.C. line. This set-up naturally would not "stay in frame" for any length of time, and results were not altogether satisfactory. The decision was finally made to construct

the new set with an automatic synchronized control, such as are used by Jenkins and Baird.

### Impedance Coupled Amplifier

The signals were being received by one of the usual short-wave sets, available everywhere. Resistance-coupled amplifiers had been used in previous attempts to pick-up the Jenkins signals; but, profiting from the experience gained in the television demonstration, the new amplifiers were "impedance-coupled".

The hook-up and constants for this power amplifier are shown in Fig. 1. Despite the predictions of dismal failure made by interested friends, the amplifiers were constructed and proved far superior to the resistance-coupled amplifiers previously used.

Care must be taken that the coupling condensers are free from leakage. If they can be charged from a high-voltage supply and allowed to stand for a while, the condition of the condensers can be determined by connecting a low-reading milliammeter in cir-

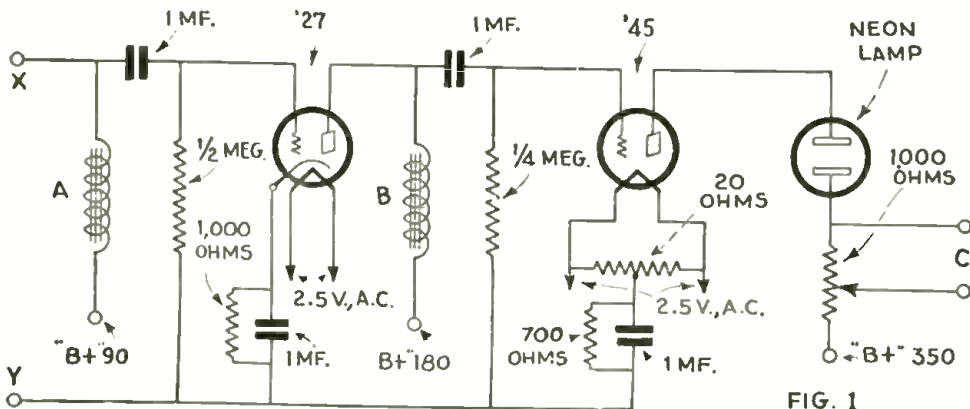

FIG. 1

Fig. 1—Above, shows "impedance" coupled amplifier; "X" goes to plate of previous tube. "Y" goes to ground of receiver; "C" to synchronizing amplifier; "A and B" are good chokes of about 30 henries each.

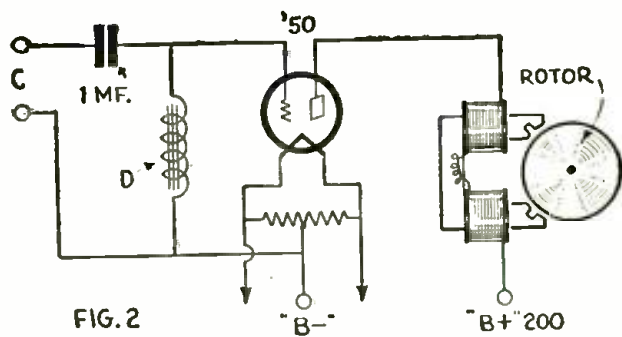
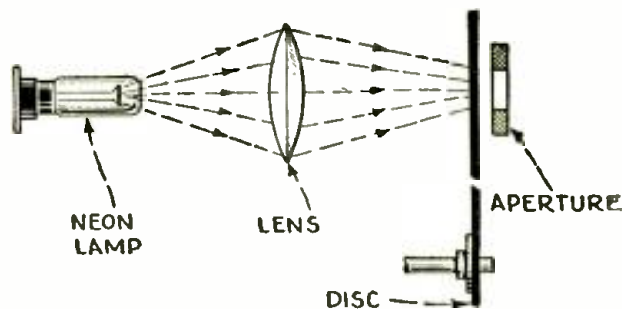

Fig. 2—(Left) shows amplifier and phonic wheel motor used in maintaining synchronism of the scanning disc. Diagram (right) shows optical system, the lens magnifying the plate in the Neon lamp, so as to give even luminosity at the scanning aperture.



cuit and noting the deflection. Those which give the largest deflections are in the best condition, with regard to leakage. Care should also be taken that the grid leads be made as short as possible. Do not be afraid to spread the equipment out. Crowding transformers and tubes makes for interference; and a compact amplifier of this sort is almost certain to result in motor-boating.

**We Build Our Own Synchronizer**

Upon learning that the price of an automatic synchronizer would run into

**Mounting of Motor and Disc**  
The mounting of the disc and synchronizing motor was made an integral part, as shown in Fig. 3. The wooden parts were constructed from maple, although almost any of the harder woods will do. The brass bearings were drilled for oil holes, and care taken that they were well lubricated at all times. The driving motor was a small universal 110-volt machine; speed was controlled by a series resistor.

Fig. 3 shows the method of mount-

ing the motors. The disc was mounted on the shaft made from a piece of 3/8" tubular brass pipe (3). This was smoothed down with emery paper and polished. The motor mounting shown at (1) was made from maple. The holes cut in the center allow the coil windings to slip through; so that the core may be bolted to the wooden mounting. The core was taken from an old transformer, cut down with a hacksaw and drilled for bolts as shown. A notch was cut in the upper part of the mounting for a place to hold the bearings. These bearings were made from 1/2" brass pipe, which was reamed to take the 3/8" shaft. The bearings were held in place with a strap of brass and two wood-screws.

The coils were wound with No. 40 B & S gauge, double-cotton-covered magnet wire, and have about 4,000 turns each.

The gear was discovered in the shop of the local machinist but, even if it becomes necessary to purchase a 48-tooth gear (60 teeth for 60-hole scanning), the total price is still low.

The disc was made from light aluminum by the method already described in the July-August issue of this magazine (using a large bed lathe). The teeth T shown in the core at (2) were cut in with a hacksaw to match the gear teeth. The small universal motor was coupled to the disc shaft with a short piece of rubber hose, and this motor was mounted on a shelf as shown in Fig. 3.

A side view of the synchronizing motor with the gear in place is shown

(Continued on page 315)

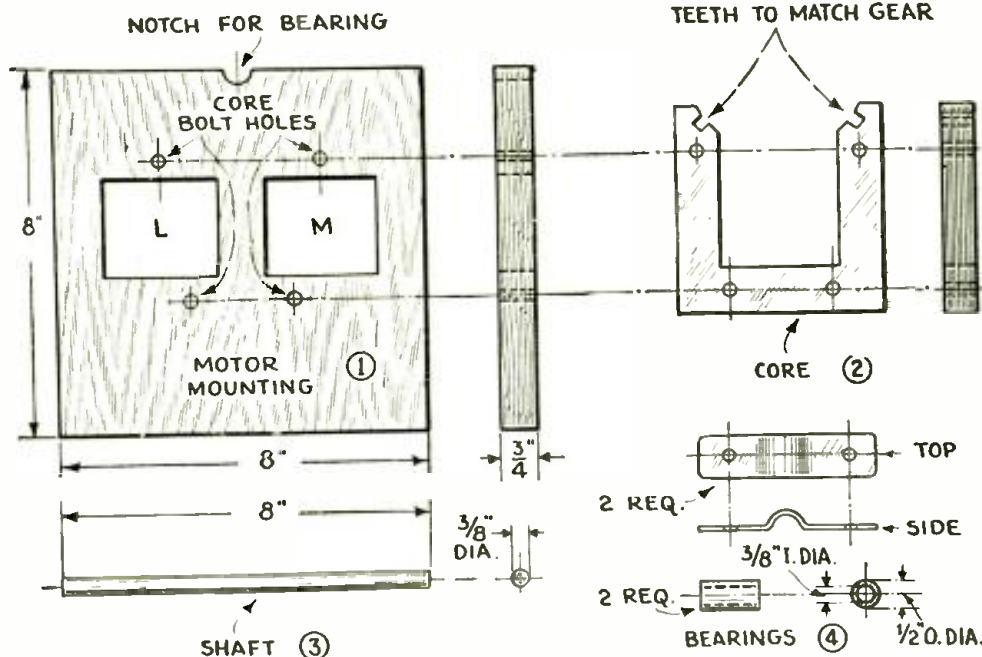

two figures, we decided to construct our own. The amplifier for this motor was made of odds and ends available around the laboratory. The tube used was a '50; but a '45 is sufficient, as we later discovered. The choke coil "D" was an old one; the secondary of an audio transformer will do nicely.

It is not necessary to make any pretense at careful construction, as no "tone quality" is necessary, and minor noises in this circuit will not affect the operation of the motor. A husky "B" power device was arranged for this amplifier, which had a very small filter; sufficient to make the A.C. ripple only just noticeable in the background.

Above—Details of scanner, showing how to lay out the motor mounting blocks and also the laminated transformer steel core for the phonic motor.

Fig. 4—At right, shows arrangement of the toothed rotor, which may be a soft iron gear with the proper number of teeth, together with field coils and laminated frame.

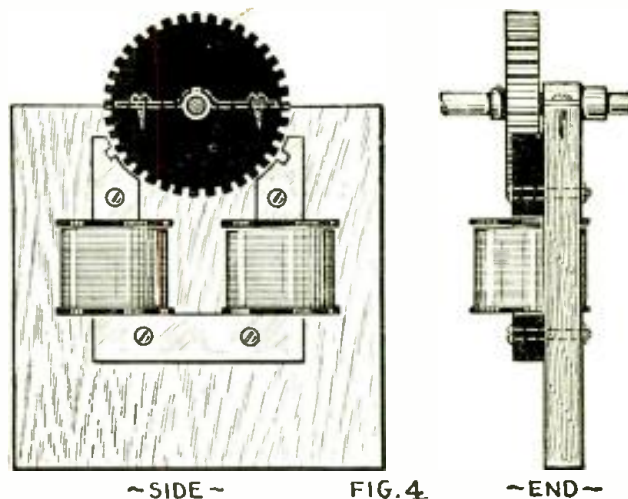

# New HELICAL MIRROR for TELEVISION SCANNING

The accompanying article describes the new helical scanning mirror devised by an American inventor. This scanning device is built up from a series of solid cylindrical blocks of black glass, ground and polished to form a series of slender reflecting surfaces, arranged in angular stepped relation to one another, so that they form a helix of one turn on the shaft. As the helical mirror rotates it causes a beam of light to scan the image from side to side and also from top to bottom.

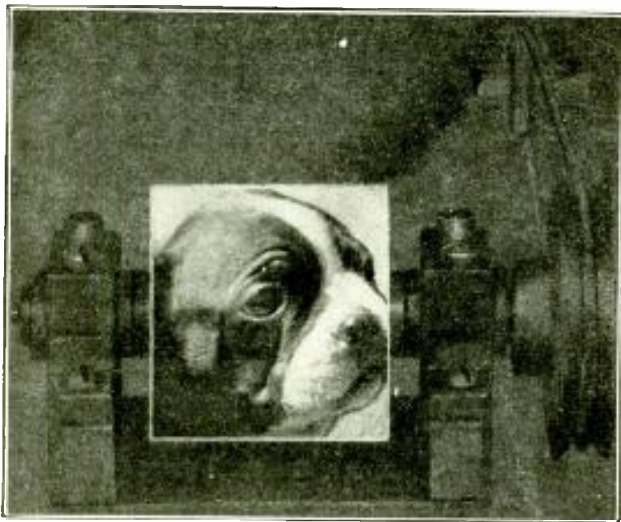

Fig. 5—At the television transmitter the subject, the image of the dog's face for example, is projected on to the revolving helical mirror, and from the mirror on to the photo-electric cell.

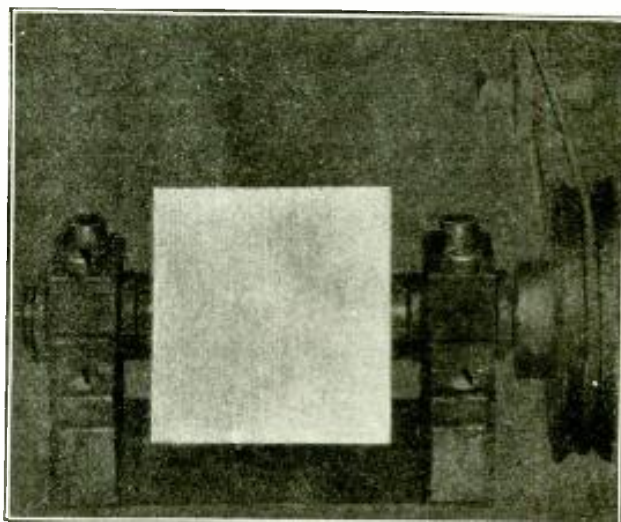

Fig. 4—Here we have a photograph of the helical mirror rotating at 600 R.P.M. Note the dead flat and square mirror effect.

**A** SHORT while ago, in the pages of this journal, we illustrated and described the mirror-scanning system devised by the Telehor Company of Germany. We are pleased to present herewith the latest American mirror-scanning system devised by Mr. D. B. Gardner of Los Angeles, California. Mr. Gardner, who has taken out a patent on his new system of helical mirror scanning, asserts that the unusual mirror system which he has devised is a better and more perfect scanning system than that developed by the Telehor concern.

In the diagram, Fig. 1, there is shown the general arrangement for the pick-up of the picture image, either from a film or an original object; the image being reflected from the revolving helical mirror through a lens on to the photo-electric or light-sensitive cell.

It will be apparent, after a little reflection, that by using a large number of mirror strips arranged as

shown in the illustration herewith, a very smooth and continuous scanning action takes place.

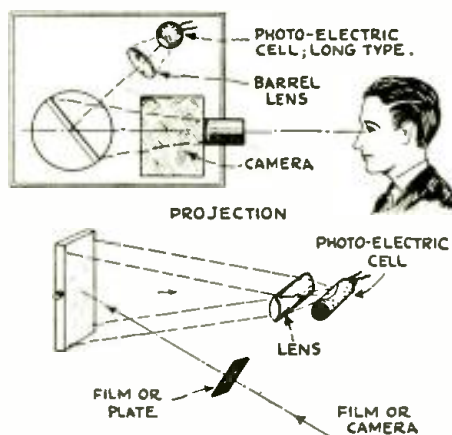

Fig. 1—Shows how the Gardner helical mirror is used at the television transmitter, the image from the film or original object itself being projected upon the mirror, and from the mirror through a lens on to the photo-electric cell.

## How Helical Mirror Is Built Up

Mr. Gardner builds up his helical mirror from solid cylindrical blocks of black glass, which are ground and polished to form a series of slender mirror surfaces, tangential to the center-line of the device and stepped round the axis or center-line.

For the small helical mirror of Mr. Gardner's design, shown in Fig. 3, only 1/200-H.P. is required for the driving motor, when the size of the screen surface is 2 x 2 inches; but larger helical mirrors can, of course, be used.

Note the picture of the revolving helical mirror turning at 600 revolutions per minute (R.P.M.) at Fig. 4. Also note particularly, the dead, flat-and-square-mirror effect. The single point of light noticeable on the center section of the stationary helical mirror in Fig. 3 has now become a closely-packed flood of light covering the total area.

**Transmission**

At a television transmitter the image such as that of a face, etc., is projected upon this seemingly flat surface; as shown in Fig. 5, where the face of a dog is observed. The running point of light is thus stopped or dimmed at those points occupied by the image. The photo-electric cell is arranged to receive the reflected light beam from the revolving mirror, responding in the usual way to the succeeding variations of reflected light; and translating them into minute electric currents, which vary in synchrony with the changes in light.

**Receiving Image**

For receiving purposes as the diagram in Fig. 2 shows, one looks at the revolving helical mirror (screen) and sees the image as built up by the revolving mirror and the pulsations of light falling upon it from the neon tube. Note that, with the mirror system of scanning such as here shown, no disc containing spiral holes is necessary; the series of mirror surfaces taking its place. For large audiences, as in theatres, the lower part of Fig. 2, shows how the Gardner helical mirror is arranged to reflect the image upward on to a large mirror stationary, and thence from the surface of this mirror above the stage floor, to the eyes of the audience. In the scheme here shown a powerful source of light from an arc or an incandescent lamp is passed through a shutter (such as the Karolus cell, with Nicol prisms), similar to the method used by Alexanderson in projecting his large theatre-size television images.

**Mirror Forms 1-Turn Helix About Shaft**

This new scanning device in one form is made up of a plurality of rectangular sheet metal (or glass) plates, secured together on a shaft, with the plates arranged in angular stepped relation to one another, so that they form a helix of one turn

about the shaft; each plate has a mirror edge arranged close to and tangentially to the shaft, with the plates elongated so that the mirror edges are of great length and thereby reflect in an arc of almost half the diameter of the rotary apparatus. The other edge and also the ends of each plate are treated to make them non-reflectors of light, so that only the mirror edges of the plates reflect the light when the rotating apparatus is in operation.

Another invaluable factor in Mr. Gardner's invention is a rotating apparatus for reflecting light and scanning in television which, when its

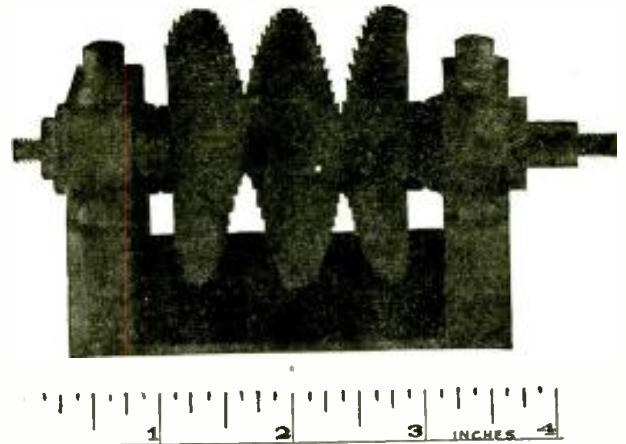

Fig. 3—Shows small size of Gardner helical mirror (shown at rest); note unit point of reflected light in center section. This size mirror provides a screen surface 2x2 inches and requires but 1/200 H.P. motor to drive it.

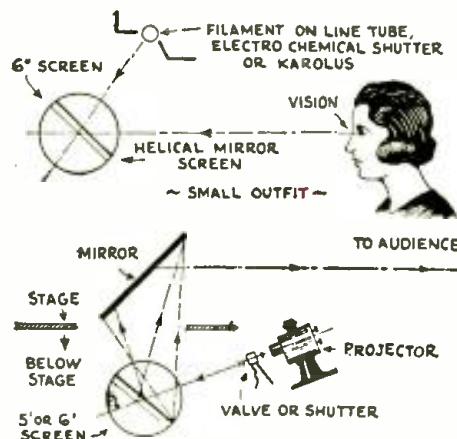

Fig. 2—Top diagram shows how television image at receiver is built up on a revolving helical mirror (or screen) and is observed by looking directly at the revolving mirror. Lower diagram shows how the television image is built up at the receiver for theatre use, the image being reflected from the revolving screen to the large mirror placed above the stage. The incoming television signal is connected to the light valve or shutter, which may be a Karolus cell.

drive shaft is mounted in a horizontal position, will reflect light in elongated vertical lines over a field, with the light traveling, line by line, from end to end of the field. In other words the reflecting edges of the plates are of considerable length, so that they reflect in a large arc, or in lines of great length, with the reflected ray of light from a lamp moving successively over the reflecting edges, point by point and from end to end of each edge, and in a direction governed by the direction of the rotary apparatus.

**Further Details**

Mr. Gardner's patent claims state further . . . that he provides apparatus that can be rotated in either direction to scan a field or object; and which, when rotated, traces rays of light in a predetermined manner, so as to cover the entire field or image in two directions on each rotation. This is a vital factor in television scanning.

The mirrors of the scanning appliance when assembled form a helix that can be rotated in either direction for scanning purposes. The mirrors are

(Continued on page 311)

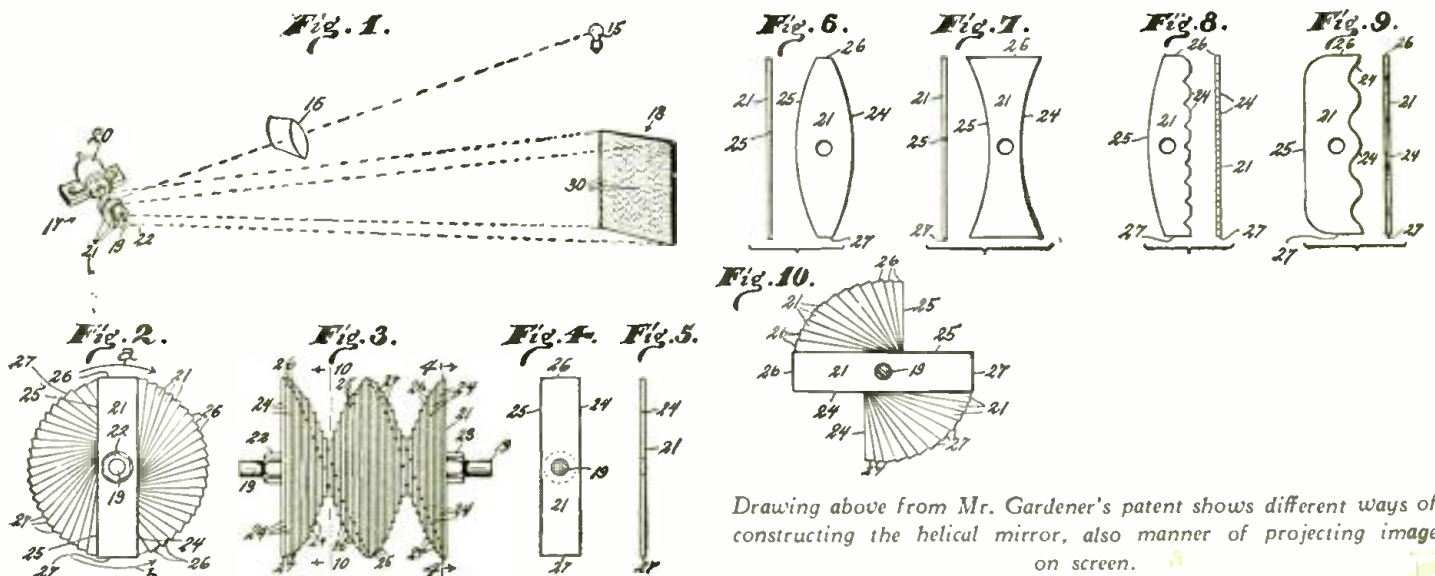

Drawing above from Mr. Gardner's patent shows different ways of constructing the helical mirror, also manner of projecting image on screen.

# SYNCHRONOUS IMAGES WITH A HOME-BUILT MOTOR

## How to Hold That Image Steady

By CLYDE J. FITCH

Electrical and mechanical details required for building your own synchronizing motor, so essential for maintaining constant speed for the scanning disc. The parts required are inexpensive, and the data here presented for the first time, is just what every "Television Fan" has been looking for.

THE problem of synchronizing the television scanning disc of the receiver with that of the transmitter is one of the most important which the experimenter has

factory. Furthermore, methods of control which depends upon some independent device at the receiver (such as a tuning fork of constant vibrating frequency) will not do. In a 48-line

greater accuracy than those employed for the transmission of photographs or still pictures is essential.

The ordinary electric motor varies slightly in speed, wavering a little above and below its normal rating; this is called "hunting." This fluctuation is due to slight variations of the supply voltage, and slight variations in the load on the motor—part of the load being the air frictional resistance, which is not constant. When both transmitter and receiver are operated from the same A.C. supply source, and synchronous motors are employed in each machine, perfect synchronism obtains. If the transmitter fluctuates slightly in speed, the receiver will likewise fluctuate and always maintain a clear image. When the receiver is operated on a different source of supply voltage, then trouble arises; while the receiving operator may be clever enough to hold his machine in constant speed for a long period of time, the transmitter may vary slightly and throw the image out. This is obviously beyond the control of the receiving operator. Holding a machine in synchronism manually, by means of a variable resistance

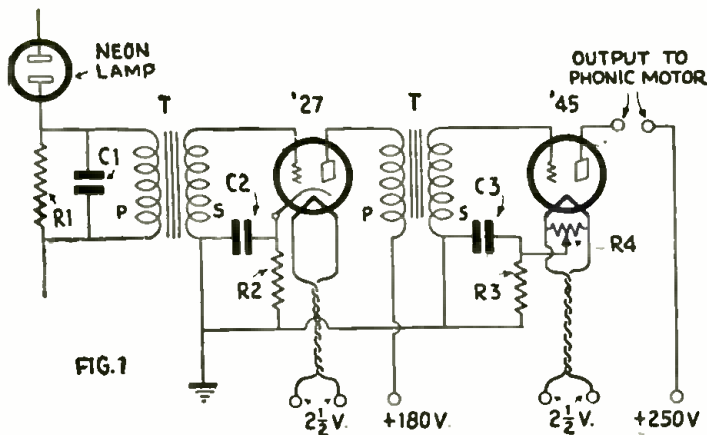

Fig. 1—At left, shows amplifier circuit for synchronizing (phonic wheel) motor, to be mounted on the same shaft with the main disc driving motor. The voltage drop across the resistance "R1" supplies the current for the phonic wheel motor.

to face, for upon its solution depends the success of image reception. Too many have neglected this important factor, and have tried to receive television programs on manually controlled, non-synchronous machines, with consequent discouraging results; a clear image may be obtained for a fraction of a second, only to pass away in a blur and never be found again. It is absolutely necessary that perfect synchronism be maintained. The slightest deviation will destroy the image. Yet, in spite of the great mechanical precision required, the problem of synchronizing is not a difficult one to solve, once the necessary apparatus is made; for with it, automatic synchronism takes place, and the operator has merely to bring the scanning disc up to synchronous speed; after which it will continue running in step with no further attention.

### Manual Control Is Difficult

It has been demonstrated repeatedly that manual control of the speed of the receiving television is not satis-

factory. Furthermore, methods of control which depends upon some independent device at the receiver (such as a tuning fork of constant vibrating frequency) will not do. In a 48-line

Figs. 2 and 3—At right, show field-magnet circuits of synchronizing motor here described by Mr. Fitch. This motor comprises simply a toothed iron wheel, arranged to be rotated near the poles of an electro-magnet. Usually, the wheel and also the field are built up of sheet iron or transformer steel laminations.

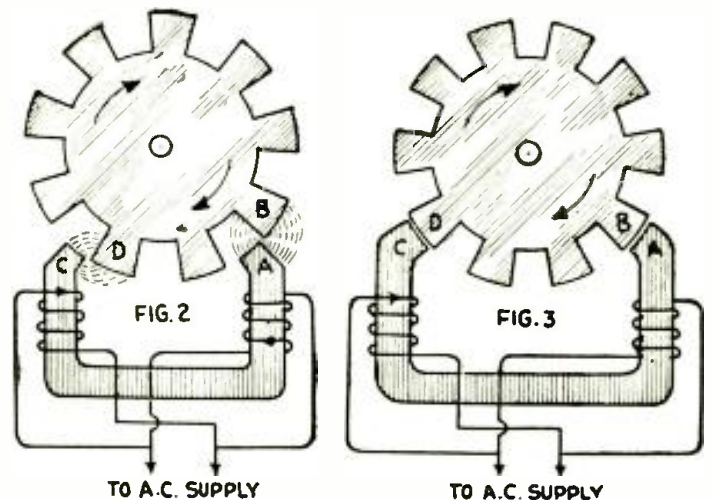



in the motor circuit, is about as simple as balancing an egg on end.

**Automatic Synchronization**

The only satisfactory methods so far employed are those in which either a synchronizing signal is transmitted from sender to receiver, or part of the image signal is employed for synchronizing purposes. Baird, in England, employed the former method. An A.C. generator was driven by the motor of the transmitter's scanning disc, and the alternating current thus generated was superimposed upon the same carrier wave on which the image signal was impressed. At the receiver, a small synchronous motor, actuated by this synchronizing current, was employed for controlling the speed of the receiving televisior. If the speed of the transmitting apparatus fluctuated, the synchronizing current would also fluctuate in frequency; and the motor at the receiver, which is controlled by this synchronizing current, would likewise fluctuate and always maintain a clear image. The second method is employed in this country and will be described in more detail.

**Utilizing the Scanning Frequency**

Those who have listened in on a television signal coming through a loud speaker have no doubt been impressed by the loud whine, of uniform pitch but of fluctuating quality and value. This is caused by the holes in the scanning disc, at the transmitter, interrupting the light impressed on the photoelectric cell. In every television signal this predominant frequency exists. In a 48-hole, 15-frame disc, this frequency is equal to 48 times 15, or 720 cycles per second; because 720 holes pass by the cell each second. In a 60-hole, 20-frame disc, it is equal to 60 times 20, or 1,200 cycles per second. If the speed of the transmitter changes slightly, this predominant frequency will also change. By means of a filter circuit at the receiving end, current of this frequency can be isolated from the main image-signal, and employed for controlling the speed of a small synchronous motor attached to the shaft of the receiving televisior. Since there is very little

power available from this synchronizing current, the synchronous motor, (in this case called a phonic motor) is mounted on a common shaft with the main driving motor, and serves to "lock" it in the proper speed relation. The main driving motor is adjusted for a speed as nearly synchronous as possible; after which the synchronizing current is switched into the phonic motor.

Obtaining and maintaining synchronism by this method, therefore, resolves itself into: first, isolating the predominant frequency from the image-signal by means of a filter; second, amplifying this current with a synchronizing amplifier; and, third, applying this current to a phonic motor attached to the main shaft of the receiving televisior.

**The Filter**

The filter need not be very elaborate. In fact, even if no filter is employed, the main predominant frequency will be so much more powerful than other frequencies, that it will determine the speed of the phonic motor. Therefore, it may be included as part of the synchronizing amplifier.

*If*  
**You are Getting**  
**GOOD IMAGES**  
**Tell other readers**  
**"How You Do It!"**

We will pay good rates for articles explaining in detail how to build **TELEVISION RECEIVERS** —"Tuners" and "Scanners".

**TELEVISION NEWS**  
 96-98 Park Place New York City

**The Synchronizing Amplifier**

This amplifier is easily built; since the problems of amplifier design, as regards tone quality and overloading of tubes which are important in sound amplifiers, may be neglected here. A two-stage amplifier is recommended; the circuit is shown in Fig. 1. The power supply for the amplifier may be obtained from the power pack of the receiver; or a separate power supply may be built for the purpose if preferred.

The input of the amplifier should be connected to some part of the neon tube circuit, so that part of the image signal can be amplified. Neon lamps are connected to the television receiver output in many ways, which have been shown in other issues of this magazine. By placing a resistor (R1 in Fig. 1) in series with the neon lamp, the image voltage may be obtained from the drop across this resistor and applied to the input of the synchronizing amplifier. A 10-watt, 4000-ohm resistor may be used. A condenser, C1, placed across this resistor, serves to bypass the high image frequencies; a 1/4-mf. capacity is suitable.

The audio transformers T may be of any high-ratio type, such as were employed in old battery receivers; since quality is not important. The synchronizing current is passed

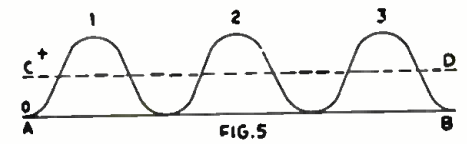
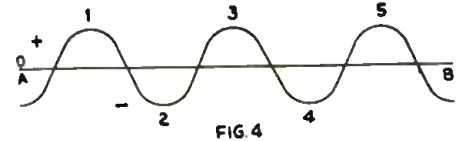

Figs. 4 and 5—Showing a sine wave A.C. (Top) and a pulsating D.C. in lower diagram.

through the first transformer to the input of a type '27 tube. The condenser C2 may be 1 mf. and the bias resistor R2, 2,500 ohms, when using the plate voltage specified. The type '45 output tube has a bias resistor R3 of 1,500 ohms, bypassed by the condenser C3 of 1 mf. capacity; a 20-ohm center-tapped filament resistor R4 is employed. The output of the '45 tube is applied directly to the magnet coils of the phonic motor. It may be advisable to connect a 0.1-mf. condenser across the output terminals. No output transformer is used; the D.C. plate current serving to polarize the phonic motor magnet as described below.

**The Phonic Motor**

The phonic motor is similar in principle to the synchronous motors employed in electric clocks; it consists merely of a toothed iron wheel arranged to be rotated near the poles of an electromagnet. The principle of its operation can be shown with reference to the illustrations of Figs. 2 and 3. Fig. 2 shows the toothed wheel and the electromagnet. The wheel is assumed to be rotating in the direction of the arrows; it is necessary to start the motor by hand before it will continue to run. At the instant shown, the poles of the magnet are between two teeth of the wheel; now assume that the current in the coils is increasing as one half-cycle of the A.C. supply passes through them. This excites the magnet's poles, so that pole A attracts the soft iron tooth B and pole C attracts tooth D; the magnetic lines of force being indicated in the illustration. Thus the wheel is pulled around in the direction in which it is rotating.

By the time the teeth B and D rotate to a position opposite the poles of the magnet, as shown in Fig. 3, the alternating current has decreased to zero; and there is no magnetic attraction. The momentum of the wheel carries it on, however, past dead center, at which time the next half-cycle of the A.C. supply excites the poles and attracts the next two set of teeth.

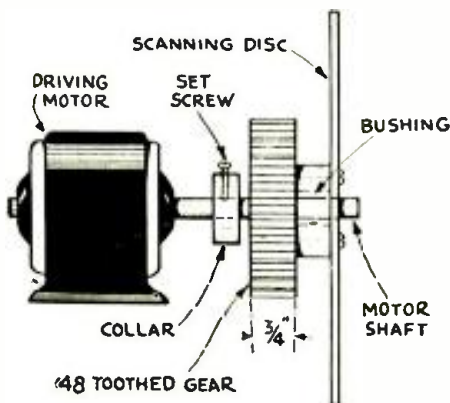

Fig. 6—Side view of scanning disc and toothed gear of phonic wheel motor, both mounted on the same shaft.

Thus, a tooth passes by one of the poles of the magnet every half-cycle (or two teeth per cycle), and the wheel runs in step with the frequency of the A.C. supply. For maximum efficiency, both the toothed wheel and the magnet should be laminated.

In our 48-line, 15-frame picture, the synchronizing frequency is 720 cycles per second. Since two teeth of the wheel pass by each pole for each cycle, it would be necessary to employ a wheel having 2 times 720, or 1,440

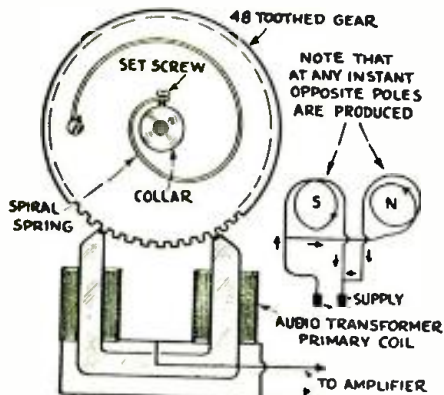

Fig. 7—Above shows front view of phonic wheel or synchronizing motor, with spiral spring connecting gear wheel with main driving motor shaft. Diagram also shows how field coils should be connected to give "North" and "South" poles.

teeth, for one revolution per second. For fifteen revolutions per second, the speed desired, the number of teeth would be 1,440 divided by 15 or 96—just twice as many teeth as there are lines in the picture.

By polarizing the magnet, it is possible to have synchronism with only one tooth passing by the magnet pole per cycle. This cuts the number of teeth for a 48-line image down to 48. For the same reason, the number of teeth required for a 60-line image would be 60. The curves of Figs. 4 and 5 explain this. Fig. 4 shows a pure A.C. wave, the line A-B representing zero voltage. In a non-polarized motor, both positive and negative half-cycles cause magnetic attraction between the magnet poles and the teeth.

By superimposing the A.C. on a direct current (which occurs when the motor coils are connected in the plate circuit of a vacuum tube) instead of an alternating current, a pulsating current is produced; this is shown in Fig. 5. The line A-B represents zero voltage, and the line C-D the amount of direct-current component. In this case, the resultant current reaches a maximum value once for each cycle of the A.C. component, instead of twice (when the flow is both positive and negative, as in Fig. 4), and only half as many teeth are required on the wheel for the same speed. In some cases, it is possible again to cut the number of teeth in two, and run the motor at twice the synchronous speed;

but the power obtained is not as great, and this idea is not recommended for the experimenter.

#### Building the Phonic Wheel

While a laminated toothed wheel gives the best results, unless the experimenter can obtain armature punchings with the correct number of slots, he will have difficulty in making one. As an alternative, an ordinary cast-iron gear wheel may be employed.

For a 48-line image, the Boston Gear Works' catalog No. ND48 is recommended. This gear has 48 teeth and a pitch diameter of 4 inches (outside diameter of 4.166") a  $\frac{3}{4}$ " face,  $\frac{3}{4}$ " hole, and a  $1\frac{3}{4}$ " (diameter) hub which projects  $\frac{3}{4}$  inches.

For a 60-line image, the No. ND60 is recommended; this gear has 60 teeth and a pitch diameter of 5" (outside diameter of 5.166") the other dimensions being the same as those of the 48-tooth gear.

The scanning disc is attached to the gear as shown in the side view of Fig. 6; and both are placed on the main driving motor shaft. It will probably be necessary to use a bushing to adapt the gear to the shaft. Both gear and disc should rotate smoothly on the shaft; they are not clamped to it. A collar, also shown in Fig. 6, is attached to the shaft by means of a set-screw. A spiral spring, made of brass wire, connects the collar to the gear; one end passing around the set-screw of the collar and the other being attached to a screw in the gear. This is shown in the illustration of Fig. 7.

The purpose of the spring is to take up any variations in the speed of the motor. The gear and disc will always run at the correct speed. If the motor's speed varies, it will tend to wind up or unwind the spring—the spring tension finally adjusting the speed to normal.

The two coils of the magnet may be primary coils of old A.F. transformers. Be sure to connect them in parallel in such a way that they will not oppose each other; that is, when a direct current passes through the coils, one pole tip should have a north pole and the other a south pole. The turns should pass in the direction shown in the illustrations of Figs. 2 and 3.

The laminated core may be part of a small transformer core. It makes no difference how many teeth are spanned between the two pole tips; therefore any suitable core may be employed. It is important, however, to shape the pole tips so that they will take the general form illustrated in Fig. 7. Then the core should be mounted on a common base together with the driving motor; so that the pole tips are very close, but not touching, the gear teeth.

#### Operation

To operate the apparatus, it is first necessary to bring the main driving motor to approximately synchronous

speed by means of a variable resistance in series with the motor circuit. For a 48-line, 15-frame image this speed is 900 R.P.M. (15x60); and for a 60-line, 20-frame image, 1200 R.P.M. (20x60). The driving motor should have the correct speed rating.

After the correct speed is obtained, connect the phonic motor coils to the output of the synchronizing amplifier, Fig. 1. This will then hold the speed to the proper value.

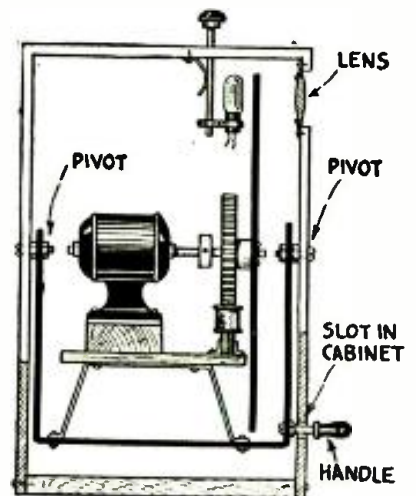

Fig. 8—Side view of television scanner cabinet, showing how motor can be swung on pivoted cradle, so operator can "frame" image by swinging handle in slot.

Though the disc may be running at exactly the same speed as the one at the transmitter, isochronism, instead of synchronism, is likely to occur (see the Mar. - Apr. issue, page 66); in this case, the image will be out of frame. Half of it may be at one side of the viewing screen and the other half at the other side; corresponding to what sometimes occurs in moving-picture theatres when the film is not correctly spliced. To frame the image, it will be necessary to turn both driving motor and synchronizing magnet around the shaft, either with the direction of motion, or the reverse; depending upon the conditions. Therefore, the motor and magnet should be mounted upon a platform that can be rotated by hand. Fig. 8 shows one method of doing this but, of course, the builder may employ any suitable method, depending upon the apparatus available.

In the method of Fig. 8, the whole assembly is placed in a wooden cabinet. The motor mechanisms are hung from an iron strap pivoted on the cabinet at both front and back; the pivots being in line with the shaft. In the front of the cabinet is cut a circular slot through which passes a threaded bolt on which is screwed a handle. The handle can be loosened, moved along the slot until the image is framed, and then tightened against the cabinet; thereby holding the setting fixed. The motor's supports must be very rigid.

# BELT SCANNERS

**T**HE accompanying pictures show one of the simplest, yet not so well-known, forms of television scanner; this employs a perforated belt, instead of a revolving disc containing a spiral of holes. There are a number of different ways in which these belts can be arranged to conserve space; such as having the belt run over a series of pulleys instead of letting it spread out in the fashion shown in the diagrams herewith.

A straight line is drawn from one end of the belt to the other, on a

**Scanning the image by means of perforated belts, driven by motors, presents a new angle for the experimenter. The belts may be laid out more easily than scanning discs and can be made of a variety of materials.**

Thus if we had 60 holes and the image was one inch high, the belt would be approximately 60 inches

reflected from the face, for example, pass through the lens and a diaphragm 3 which contains a rectangular opening the size of the image as shown at 2 and the light finally reaching the photoelectric cell. The scanning belt moves downward between the diaphragm and lens in this particular arrangement; 4 represents the wires connecting the photo-cell with the multi-stage amplifier. If this arrangement is to be tried out experimentally, four to five stages of resistance-coupled amplification will be necessary to boost the photo-cell currents suffic-

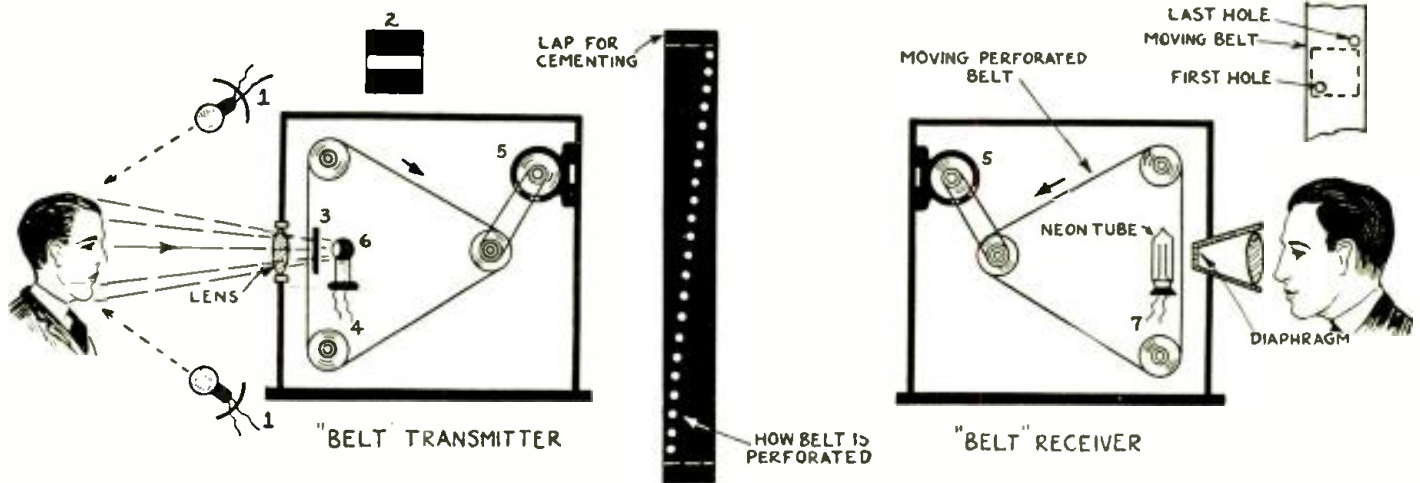

At Left: Perforated belt scanning reflected image at transmitter. At Right: How scanning belt revolves in front of neon tube and builds up image, which is magnified by the lens.

diagonal; and the holes are of such a size that the second hole scans a path alongside that scanned or traversed by the first hole, etc. In other words, if the width of the picture or image as scanned by the moving belt, is one inch and there are 60 holes, then each hole must have a diameter of 1/60 of an inch. The distance between each hole and its neighbor, along the belt, is determined by the vertical height of the picture, since the distance between the centers of any two adjacent holes is equal to the height of the image. (For use in receiving American television images the belt should move horizontally so that the image is scanned from left to right.)

long, allowing for lapping and cementing at the ends.

The scanning belt may be composed of any of a number of different materials, such as cloth, paper, thin sheet metal (such as thin steel or brass), celluloid, etc. As the detailed drawing at the upper right-hand corner of our illustration shows, the first hole scans the left-hand side of the picture; while the last hole scans the right-hand edge of the picture; the intermediate holes scan the progressive strips of the picture in between these two.

Looking at the diagrams of the scanning-belt transmitter, 1 represents powerful lamps, illuminating the subject to be televised; the light rays

iently to operate the neon tube at the receiver.

The driving motor, in either case, is shown at 5. At the receiver the neon tube is indicated at 7, and a diaphragm containing a square hole the size of the image is used in front of the scanning belt. If experiments are tried with this arrangement, care must be taken to see that the scanning is done in the same direction at both transmitter and receiver. Where both the transmitter and receiver are to be located in the same room for demonstration or testing purposes, one motor only is required; as it can drive both belts from a common shaft.—H. W. S.

## In Our Next Issue

**THE PROMISE OF TELEVISION.** by Merlin H. Aylesworth, President, National Broadcasting Company

**HOW I BUILT MY AMATEUR HOME RADIOVISOR,** by Edward Deane, Jr.

**GREATER DETAIL—HOW TO OBTAIN IT WITH NEW SHAPE OF SCANNING APERTURES.** by Wolf S. Pajes

**HOW TO MAKE A SYNCHRONOUS SCANNING DISC MOTOR,** by Kenneth E. Sherman

**THE DESIGN OF A COMPLETE TELEVISION SYSTEM.** by C. E. Huffman, Television Engineer, De Forest Radio Co.

**LATEST NEWS OF TELEVISION DEVELOPMENTS,** by Jenkins, Sanabria, Columbia and Others. Also Construction Articles on Television Receivers and Scanners

# The New BAIRD TELEVISION

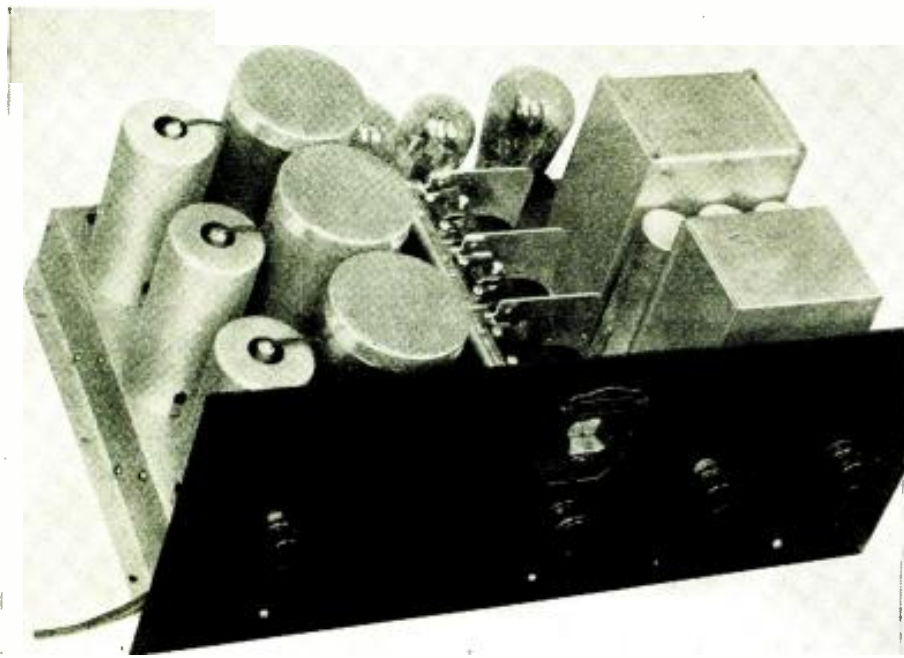

Fig. 2A—Another view of the new Baird combination television and short-wave receiver, covering all wavelengths from 16 to 200 meters. Note the well-designed shielding of all coils and tubes.

The newest design of Television and Short Wave Receiver designed by Hollis S. Baird, famous Boston television and short wave engineer, is here illustrated and described. This receiver, unlike many so-called "television" tuners, has its radio-frequency stages especially designed to pass a wide band of frequencies. This set tunes to all wavelengths between 16 and 200 meters. Its audio amplifier, of the resistance-coupled type, provides uniform amplification over a range from 15 to 40,000 cycles; so essential to the reception of good television images. The description was prepared by Joseph Calcaterra, well-known radio expert and author.

WHILE the average broadcast listener, using a standard broadcast receiver, is finding it almost impossible to cut through the barrage of local and nearby stations, owners of efficient short-wave receivers are tuning in short-wave transmitters located half way around the world, at all hours of the day and night and during seasons when static interference makes reception of regular broadcast stations almost impossible.

There are now over 200 short-wave stations all over the world which are broadcasting voice programs on regular schedules, the most important stations received regularly in the United States being located in Winnipeg, Canada; London, England; Paris, France; Berlin, Germany; Rome, Italy; Mexico City, Mexico; Buenos Aires, Argentina and Sydney, Australia.

Short-wave radio has removed the barriers of space between the peoples of every corner of the world. News from polar expeditions, long distance flyers and events all over the world are received by owners of short-wave receivers as the events happen.

Short waves are now carrying on regularly, communication and entertainment over distances far beyond the dreams of the most hopeful visionaries of a few years back.

The development which has taken place in the transmission and recep-

## Parts Required for Baird Receiver

Stock No.	Quan.	Part and Type	No. on Diagram
51	1	Chassis, all mounted, with 8 sockets riveted S1, S2, S3, S4, S5, S6, S7, S8 3 coil shields C81, C82, C83 3 tube shields TS1, TS2, TS3 2 condensers C10, C13 and 1 3-post binding strip	
		<i>Gnd., Short Ant., Long Ant.</i>	
52	3	Coil Sockets	S9, S10, S11
53	2	Pig-tail Resistors	R1, R2
54	3	.0001 Mfd. Condensers	C8, C11, C17
55	3	Screen Grid Clips	
56	2	.02Mfd. Moulded Condensers	C9, C12
57	2	Jacks	J1, J2
58	1	Block Condenser C18, C19, C20, C21, C22, C23	
59	1	Block Condenser	C24, C25, C26, C27
60	3	R. F. Chokes	CH3, CH4, CH5
61	1	3-Gang Baird Variable Condenser	C1, C2, C3, C5, C6
62	3	Electrolytic Condensers	C14, C15, C16
63	1	Baird Power Transformer	T
64	1	Baird Power Choke	CH1, CH2
65	1	Baird Gang Resistor R5, R6, R7, R8, R9, R10, R11, R12, R13, R14	
66	1	3-Condenser Strip	C28, C29, C30
67	4	Knobs	
68	1	Toggle Switch—2 pole	SW1
69	1	Speaker Terminal	Speaker
70	1	Combination Potentiometer and Switch	P, SW2
71	1	No. 9 Baird Midget Condenser	C4
72	1	No. 15 Baird Midget Condenser	C7
73	1	Buffer Condenser	C31, C32
74	1	Voltage Divider	VD
75	1	Baird Dial and Escutcheon	
76	1	Baird Front Panel	
77	2	Grid Resistors	R3, R4
78		40' Wire	
79		3-Pole Switch	SW3
80	1	Dial Bracket and Lamp	DL
81		AC Cord and Plug	P1
500		Hardware Assembly	
	15	Octocoils 15-520 meters Wave-	

tion of short waves over the range of 16 to 200 meters has been phenomenal in the past few years and much interesting and valuable information has been discovered regarding the efficiency and peculiarities of such wavelengths for long distance transmission and reception.

Careful and painstaking experimentation and testing has proved that the use of low power on the very low wavelengths (high frequencies) provides much greater carrying power than considerably higher power at higher wavelengths (lower frequencies).

The circuit and construction of the remarkably efficient Baird Universal Short-wave Receiver, one that opens up this big field of radio reception, are described in detail here.

The picture diagrams and schematic diagrams referred to in the text here are shown on special blueprints, which may be identified as follows:

Fig. 1 is the large Wiring Schematic Diagram.

Fig. 6 is the smaller Picture Wiring Diagram of the top of the chassis.

Fig. 7 is the large Picture Wiring Diagram of the bottom, or subpanel of the chassis.

The Baird Receiver is universal in its application, since it is not limited to the reception of short-wave stations transmitting voice and instrumental programs. It has been in-

# and S-W R RECEIVER..

geniously designed to serve many other purposes in the whole range of short-wave and regular broadcast reception.

In addition to bringing in the short-wave telephone signals, it can be used for code and Television reception in the range of wavelengths from 16 to 200 meters (approximately 18,740 to 1,500 kilocycles respectively), by simply changing the plug-in Octocoils especially designed for use with this type of receiver, and the operation of the simple switching arrangements provided. Its excellent audio amplifier system can also be used for phonograph reproduction by plugging a phonograph pickup into jack J1. For operation direct into the input of this amplifier, a standard pickup having an impedance of 2,000 ohms at 1,008 cycles should be employed. If a pickup having other characteristics is used, a matching transformer will be necessary to complete the pickup to the input of the amplifier. Earphones can be plugged into jack J2.

Radio listeners who have never used a short-wave receiver have a real thrill in store for them when they find how easy it is to tune in distant foreign



Fig. 2—Front view of the new Baird universal short-wave and television receiver, showing the extremely simple controls and the single tuning dial.

stations with the receiver described here.

The schematic wiring diagram of the circuit used in this receiver is shown in Fig. 1. It consists of two stages of tuned radio frequency amplification using screen grid AC tubes, a screen grid detector, and two stages of resistance coupled audio frequency amplification with a Type —45 power tube in the last stage.

Since one of the most important uses of this receiver will be in connection with Television reception, it has

been designed with a resistance coupled amplifier system capable of providing uniform audio amplification over a range of from 15 to 40,000 cycles.

Short-wave receivers equipped with transformer coupled audio amplifiers which cut off frequencies above 8,000 cycles or thereabouts are not suitable for television reception, since they do not pass the audio frequencies so necessary to give good detail to the picture.

Great care has been taken in the design of the circuit and the arrangement of the parts to eliminate all possibility of instability and distortion through electromagnetic or electrostatic coupling. All circuits have been thoroughly shielded, bypassed and filtered wherever necessary.

The highly efficient Baird Octocoils are employed to permit the use of the receiver to tune in signals over the whole range of short-wave Television and regular broadcast wavelengths.

### Mounting the Parts

Every detail of this receiving set has been so carefully thought out that the construction of the receiver is a very simple matter. When finished, it

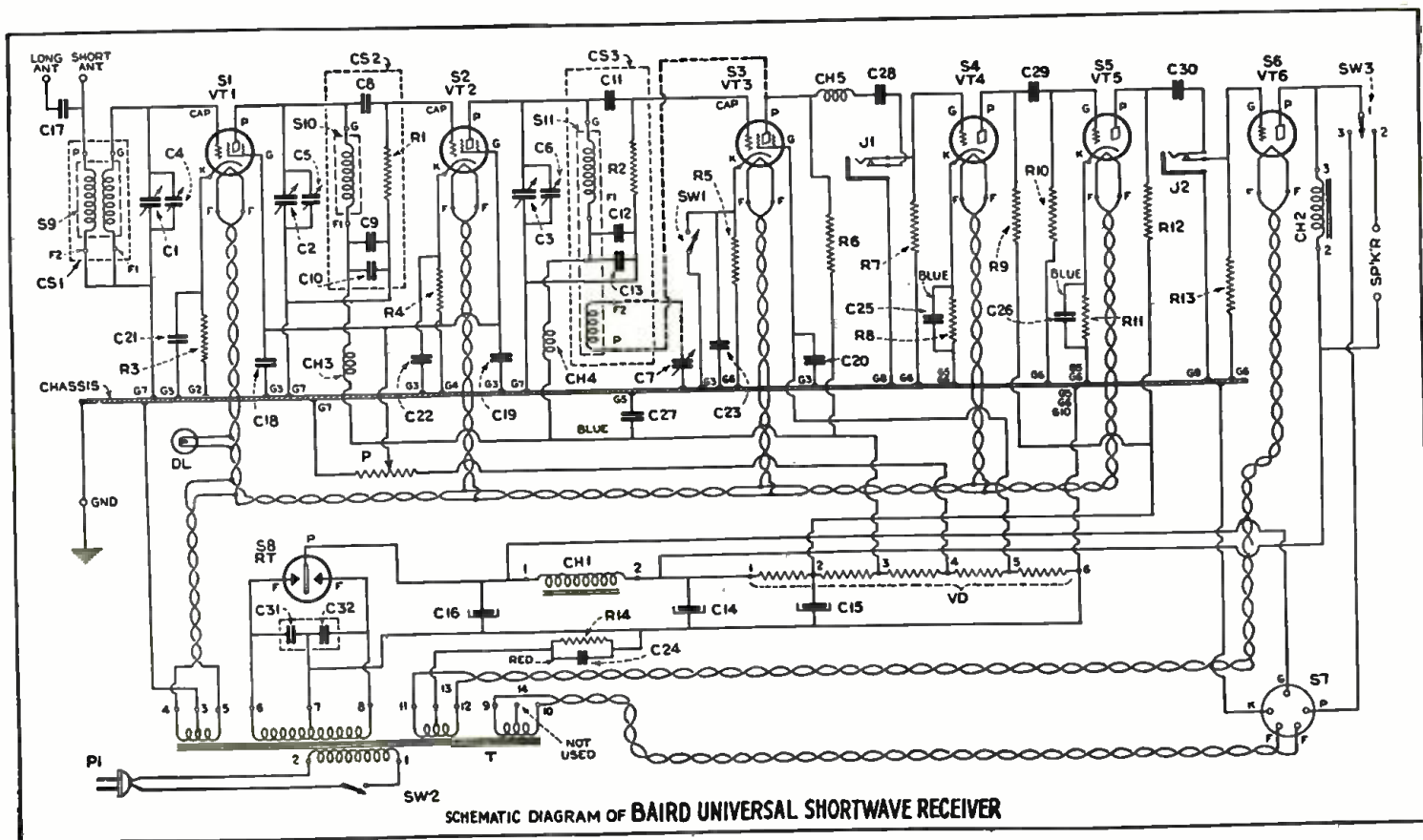

Fig. 1—Complete schematic circuit diagram of the new Baird universal short-wave and television receiver, tuning to all wavelengths from 16 to 200 meters; the audio amplifier has unusually broad frequency characteristics, so essential to perfect television reception.

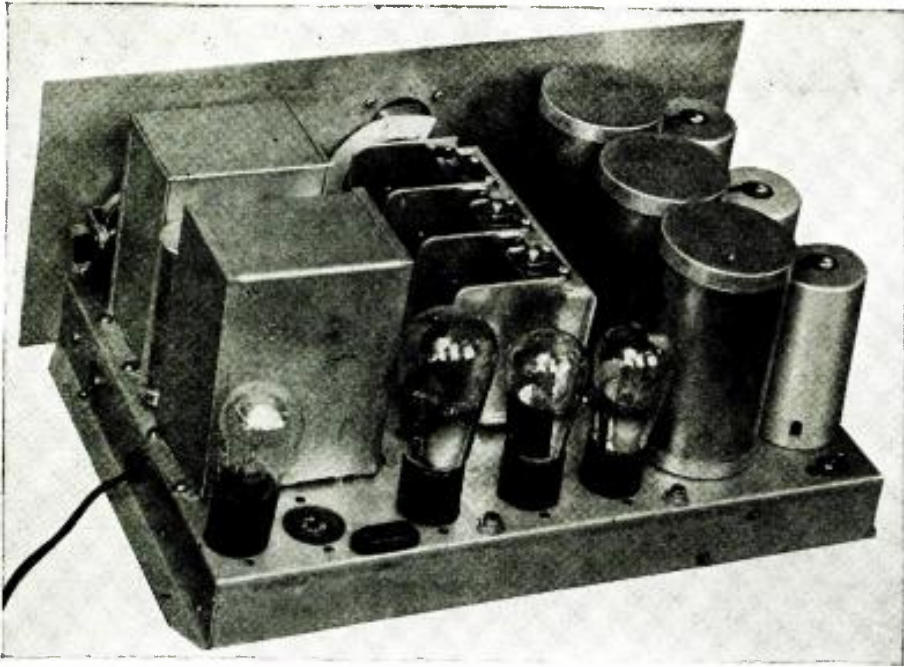

Fig. 3—Rear view of the new universal short-wave and television receiver chassis with tubes in place. The resistance-coupled audio frequency amplifier provides uniform amplification over a range of 15 to 40,000 cycles.

provides a unit that is as fine in appearance, workmanship and performance as any factory built receiver.

Every hole necessary to mount a part or bring a connection through the chassis has been punched to simplify assembly.

Sockets S1 to S8 inclusive and the bases of tube shields TS1, TS2 and TS3 are riveted to and furnished as part of the chassis. So also are the bases of the coil shields CS1, CS2 and CS3 and condensers C10 and C13.

The first step in mounting the other parts, is to slip three  $\frac{3}{32}$  round head screws into the mounting holes on the side of the gang variable condenser, with the heads of the screws on the inside of the condenser, and fasten the screws in place with  $\frac{3}{32}$  nuts. The screws will then project outward from the condenser, thus providing three studs which fit into the holes provided for them in the chassis. The condenser can then be fastened onto the studs with three nuts screwed on the studs from the under side of the chassis. A soldering lug should be fastened at the rear mounting stud as shown at G7 to provide a ground connection for the potentiometer P. Soldering lugs should be attached to the frame of the condenser at the points indicated.

Sockets S9, S10 and S11 used for the plug-in Octocoils should then be mounted, care being taken that the terminals are mounted in the relative positions shown (the F terminals toward the rear of the chassis and bent flat against the bases of the sockets to prevent the terminals from touching the cans of the condensers over which they are mounted. Mounting is effected by using the long screws and insulating bushings to

mount them at a height sufficient to clear the condensers C10 and C13, shown in Fig. 6.

Although no condenser is used under S9, this socket must also be mounted at the same height to keep the relative position of its coil with respect to the shield, the same as that of the other coils.

The bakelite strip on which condensers C28, C29 and C30 are fastened should be mounted with a clearance of about a quarter of an inch between it and the bottom of the chassis. This is done by putting spacers on the mounting screws at the desired height to serve as supports for the strip.

Switch SW1 should be mounted with the terminals toward the left side of the chassis as shown in the picture wiring diagram, Fig. 7, of the sub-panel of the chassis. Switch SW3 should be mounted with the single terminal end (terminal 2) toward the left and with the double terminal end (terminals 1 and 3) toward the right. The number 1 terminal of switch SW3 (the terminal which connects with the number 3 terminal of the double choke unit CH1, CH2) is the terminal which is nearest the sub-panel and is hidden from view when looking into the chassis as in Fig. 7.

The terminal of switch SW1 which is connected with the K terminal of socket S3 is also hidden from view in Fig. 7. These hidden terminals are shown by dotted lines.

The connections to these terminals should be made by turning the switches around, soldering the connection to such terminals and then turning the switches back into position and fastening them firmly in place.

The front panel is mounted on the chassis by means of the potentiometer P and the switches SW1 and SW3 which fasten the front panel and chassis together. All spacing washers and nuts from these units should be removed to permit mounting.

(NOTE:—It will be found that in some kits of this receiver, no provision has been made for the large half-inch holes required to mount switches SW1 and SW3 and potentiometer P in the positions shown in the photographs and layouts. In such cases, however, it will be found that a half-inch hole is provided in the chassis, just back of the detector tube socket S3, for mounting switch SW1. Another half-inch hole is provided in the side of the chassis, near the double choke unit CH1, CH2 for mounting switch SW3. In such units it will also be found that the combination potentiometer and AC switch, P and SW2 will have to be mounted in a half-inch hole provided at the extreme right of the front panel, on a horizontal line with the hole used to mount the regeneration condenser C7, and just in front of the double choke-unit CH1, CH2. The hole for

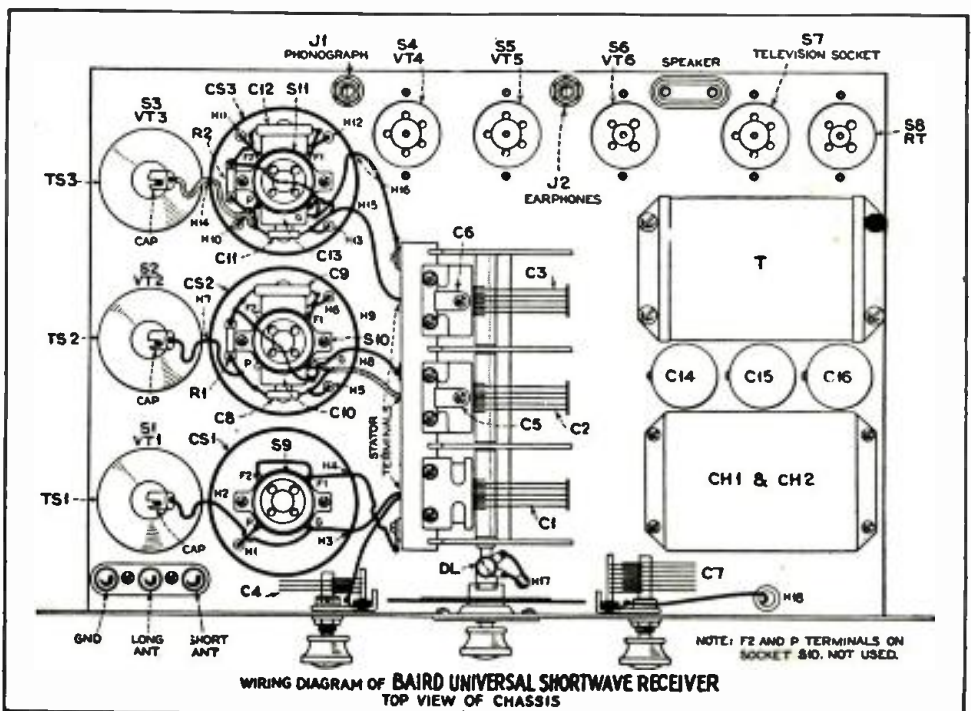

Fig. 6—Pictorial wiring diagram of the top of the new Baird chassis.

mounting condenser *C4* on the front panel will be found on the extreme left of the front panel, on a horizontal line with the mounting hole of condenser *C7* and just above the antenna and ground binding posts. In the case of such units, the front panel is assembled on the chassis with three screws and nuts. The wiring to the terminals of such parts, however, remains exactly the same regardless of the difference in their positions.)

The body of each resistor *R5* to *R14* inclusive is insulated from the metal mounting strip which holds it in place. This mounting strip is automatically grounded when it is mounted on the chassis. The ground connections of resistors *R5*, *R7*, *R8*, *R9*, *R10*, *R11*, *R13* and *R14* can therefore be made very easily by soldering one pigtail from each resistor mentioned to the mounting strip, as shown in Fig. 7.

It is important to note that the diameter of the resistor at one end of the resistor assembly is larger than the rest. The resistor assembly should be mounted so that this large size resistor locates at position *R14*. If this is not done, the values of the resistors will not be properly located and trouble will result.

Since the radio frequency choke coils *CH3*, *CH4* and *CH5* are polarized, it is important that they be located as shown and connected as follows: The terminals marked "Hi-

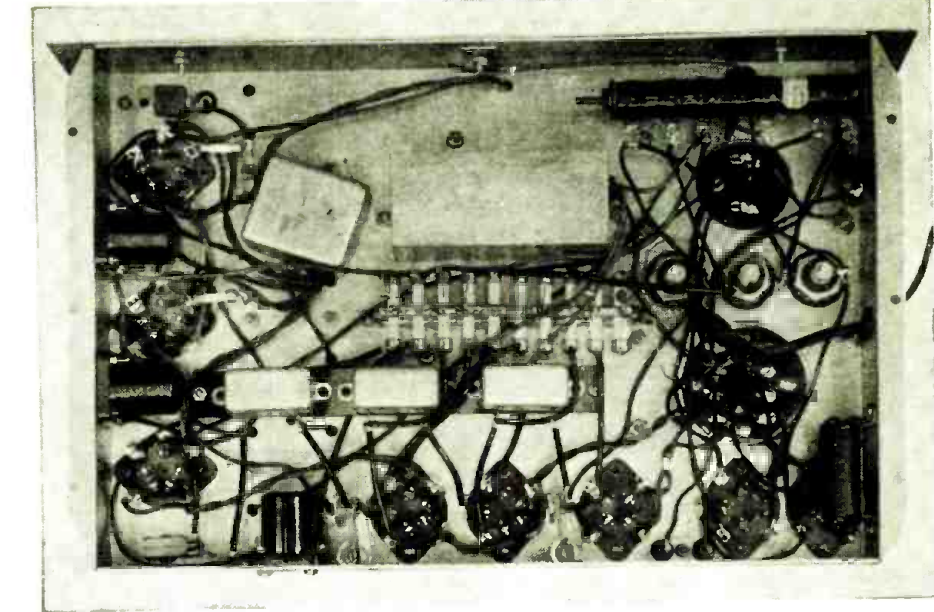

Fig. 5—Here we have a bottom view of the sub-panel of the receiver, revealing the neat arrangement of the apparatus and wiring.

Freq." on chokes *CH3* and *CH4* should be connected with their respective radio frequency transformers through holes *H6* and *H12* respectively, as shown in Fig. 7.

The terminal marked *Hi-Freq.* on choke *CH5* should be connected with the *P* terminal of socket *S3* and with resistor *R6* as shown.

(Continued on page 309)

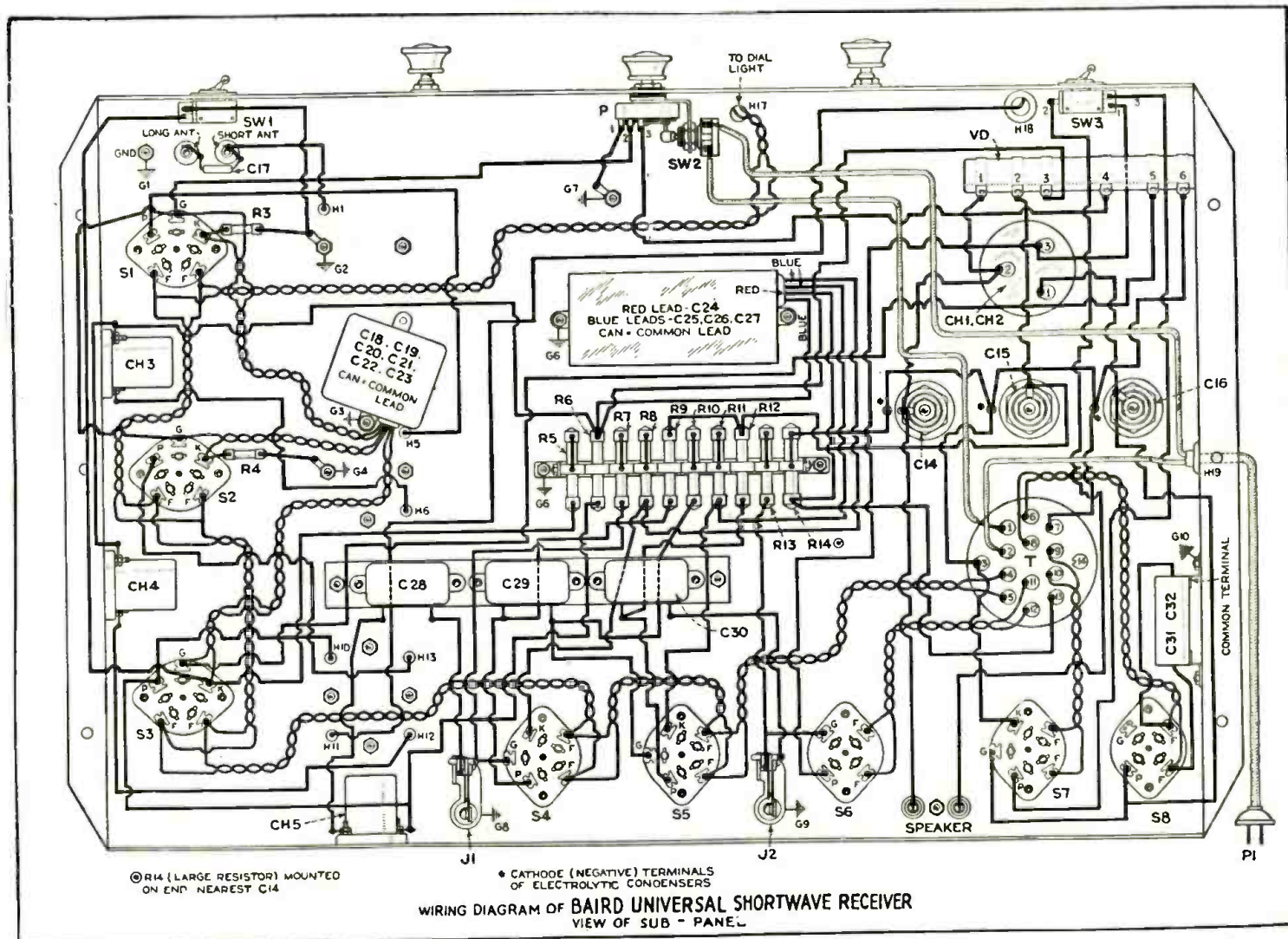

Fig. 7—Picturized wiring diagram of the new Baird universal short-wave and television receiver, the relative location of the various parts on the under side of the sub-panel being clearly shown.

# All About the KERR Cell

**I**N the equipment employed in last year's exhibition of television at Schenectady, the Kerr cell (as modified by Dr. Karolus) played an important part. This is one of the few ways in which an intense source

**What is polarized light? What does a Nicol prism do? How can one make a Kerr cell? How may home-made polarizers be cheaply made? These and other vital questions are answered here.**

of light passing between the plates, can be rotated by placing an electric potential across the two plates. If this device is inserted between a pair of Nicol prisms, it becomes an effective light valve; the light being modulated in accordance with the applied voltage. The curve of voltage against passage of light for a typical system is shown in Fig. 4, where it will be noted that the curve is not a straight line. It is necessary then, in order to avoid distortion, that we provide an initial D.C. biasing voltage; so that the variation in light is linear over the range used with respect to voltage applied. Probably the least offensive of the dielectrics which are effective in this connection is nitrobenzene; this is a liquid having a slightly yellow tint. It is a dangerous poison and can be absorbed by contact; persons have been known to die from using shoe-polish containing it.

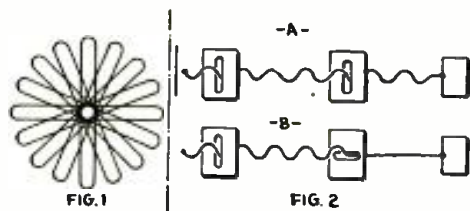

Fig. 1—"Head-on" view of light wave. Fig. 2—Diagram showing analogy of light wave action with Nicol prisms.

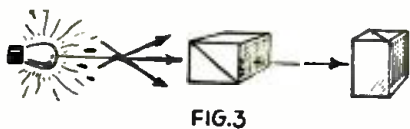

Fig. 3—When two Nicol prisms are arranged as shown, no light passes.

will result in no wave travel beyond the first diaphragm. Now, if a second diaphragm is inserted and turned so that its slit is at right angles to that in the first as in Fig. 2B, the wave motion will stop at the second diaphragm. This is an analogy to the operation of two Nicol prisms with their axes crossed. Light passing through a Nicol prism is said to be plane polarized; since it exists in one plane of oscillation only. (Technically, the first of the two prisms is called a polarizer and the second an analyzer.) If two such prisms are set up, as in Fig. 3, no light passes; but, were we able at will to rotate the first prism, we would see a gradually increasing transmission of light as the axes of the two prisms approached the parallel state.

The cell proper can be made from two small plates immersed in a glass jar of nitrobenzene, or from a composite structure of plates resembling a variable condenser in structure and electrical insulation. In fact, a small variable condenser can be very well used in constructing the device. The electrical circuit and the arrangement of the parts is as shown in Fig. 5.

of light can be modulated as to intensity. Before explanation can be effected it is necessary that we define "polarized light". A Japanese student at the United States Naval Academy once described it in this wise—"stand on head—look through crack—see polarized light." Just what he was driving at, I have never been able to figure out; but I trust my explanation will be a trifle clearer.

We cannot effect this actual rotation rapidly enough by mechanical means to make this property of value; but, by means of the Kerr cell, we can rotate the plane of polarization of the

### Efficiency of Kerr Cell

Unfortunately the Kerr cell is not a television cure-all, and can be expected to show limitations. The light efficiency of such a system is low—of the order of about 2%. The amplifier power required is, however, not great—a signal of about 200 volts is sufficient to give a good rotation, while a small home-movie lamp is a good light source. The light output will still be high as compared with that of the neon tube, despite the inefficiency. A schematic arrangement is shown in Fig. 6.

Information and prices on Nicol prisms may be obtained from Carl  
(Continued on page 311)

### Polarized Light

Light is an electromagnetic manifestation, but the wave trains advance in a particularly disordered fashion and we cannot by any means represent a light wave boldly on paper as we do an electric wave. Viewed head-on, the wave structure would appear somewhat as in Fig. 1.

Malus—many years ago—discovered that light could be polarized—that is limited to a single plane of oscillation. Later it was found that a crystal of "Iceland spar", cut along its axis and with a segment removed, could be rejoined in such a manner that it would transmit advancing light in one plane only. Two of these crystals in series, and with their axes crossed at right angles, would entirely prevent the passage of light. Suppose we have a cord drawn through a diaphragm in such a manner that one end is fixed and the other free to be moved by hand, as shown in Fig. 2A. Moving the cord rapidly up and down will result in the travel of a wave along the cord, if the slit in the diaphragm is in the position shown. Moving it from side to side

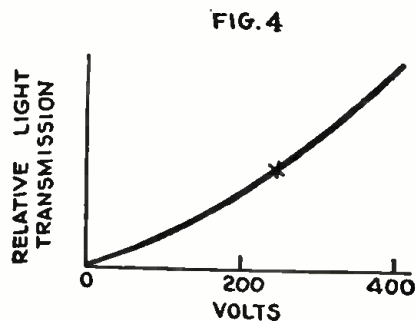

Fig. 4—Curve showing variation of light with applied voltage in a Kerr cell.

light ray between the two prisms so that we produce the same effect. The Kerr effect is named for the English physicist who, following the work of Faraday in the electro-rotation of polarized light, discovered the principle that certain dielectrics when subjected to electric strain would rotate the plane of polarization.

### How the Kerr Cell Works

If two plates be suspended in a medium of nitrobenzene, carbon bisulphide or other highly-refractive dielectric substance, the plane of polariza-

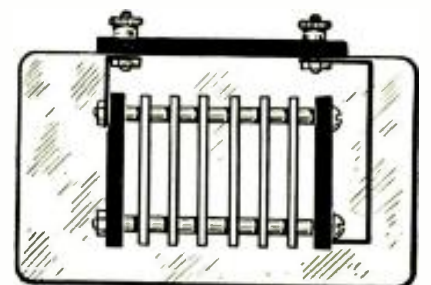
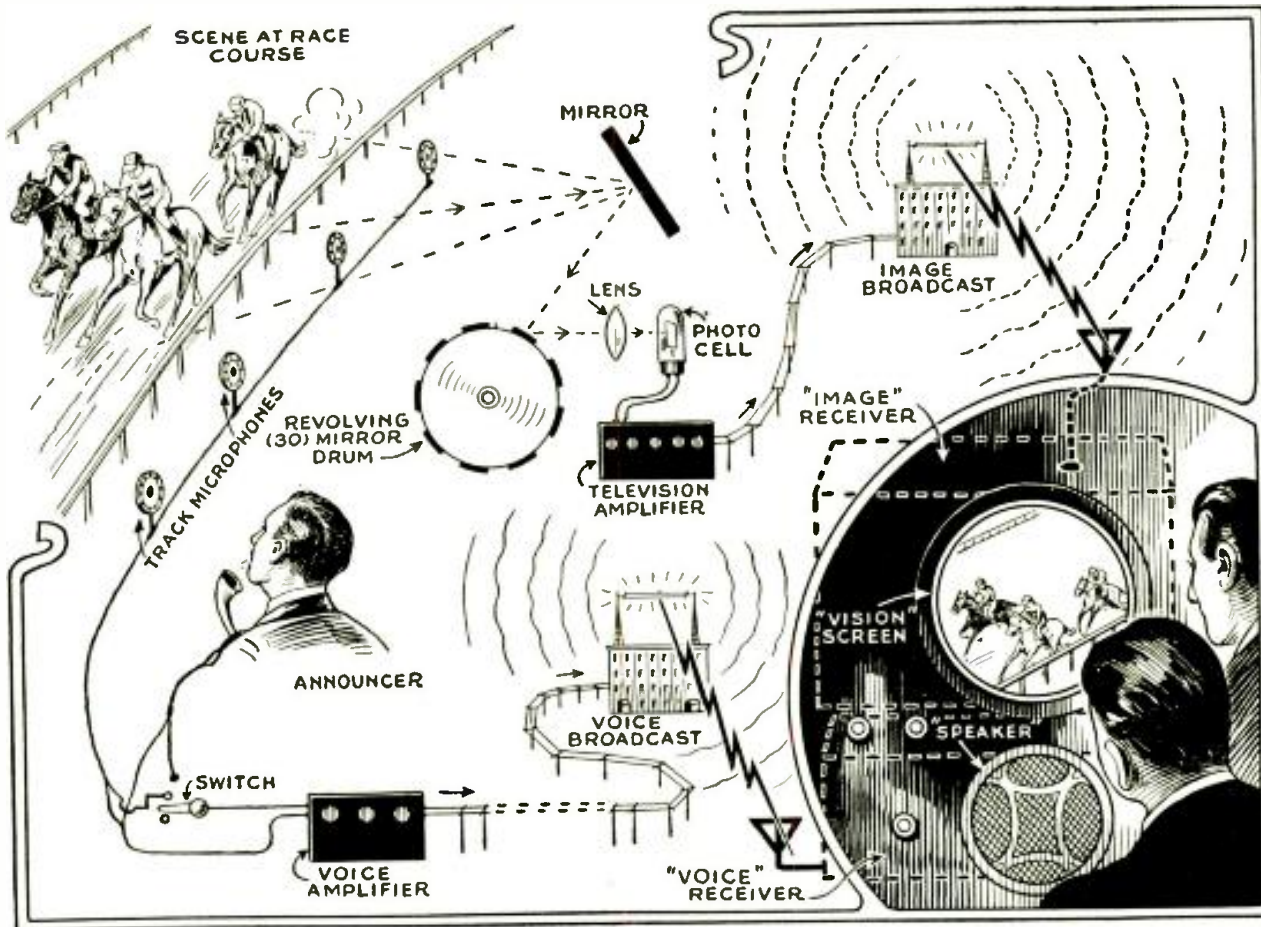

FIG. 5

Fig. 5—Kerr cell with composite electrode structure.



The famous English Derby was televised as shown in our artist's drawing. The image of the horses was picked up by the mirror and photo-cell system and broadcast as indicated. The announcer's voice and track sounds were transmitted over a separate circuit and broadcast on a different wavelength.



# The THRILL of A TELEVISED DERBY

By H. J. BARTON CHAPPLE.  
Wh. Sch. B. Sc.

How Englishman Saw First Experimental Television Transmission and Reception of the Derby Race.

**T**HE first attempt to televise the Derby was essentially a technical undertaking and was not intended to provide entertainment. The whole scheme was sponsored by the Baird Company in association with the B.B.C. (British Broadcasting Company). As a privileged participant in the preliminary tests and a witness of the final results, I am sure readers will be interested in a description of what actually took place.

The television van was transported to the famous racecourse on Epsom Downs and occupied a position against the rails almost opposite to the grand stand and finishing post. Post Office engineers laid telephone lines from this van under the course to the stands; and from there they were linked up direct with the Baird television control room in Long Acre. From here the signals passed through the B.B.C. channels to Brookmans Park and were finally broadcast by the National transmitter (261 meters).

### How the Scanning Was Done

For the dress rehearsal on the day prior to the race, seven commercial "Televisors" were arranged at the Baird Company's offices and a number of press representatives first of all

visited the race course at Epsom and made a formal inspection of the caravan and had its intricacies explained to them. Then, on returning to Long Acre, a line picture was sent through and the reporters renewed their acquaintance with those sections of the course within range of the transmitting apparatus by watching the images on the small television screen. Horses being led in parade, the finish of a race, people walking about and a car park were all plainly visible and satisfaction was expressed at what was shown; especially as the babel of sound peculiar to Epsom was reproduced with the images.

To overcome the difficulty of moving the daylight caravan about a horizontal axis to sweep the surroundings into view, a large mirror was brought into play. The mirror was hinged on the caravan side remote from the course and by setting it at various angles it reflected different portions of the course and surroundings; and it was this looking-glass image that was scanned by the revolving mirror drum, carrying thirty mirrors around its periphery. As the drum revolved the mirrors in turn caused a strip of the screen to pass through a lens onto a photoelectric cell; the individual mirror inclinations relative to each other

being such that the picture was dissected into thirty adjacent strips. The whole process was repeated twelve and a half times per second, the electrical interpretations of the image being sent along the line in the usual manner after amplification, as shown by the sketch.

### Horses on the Screen

No alteration to the existing vision apparatus was necessary at the receiving end and, with the "stage" thus set, all was in readiness for Derby Day. Punctually at 2:45 P. M. on Derby Day the scenes came filtering through on the "screen," built up by the neon lamp and its associated spirally perforated disc. They were somewhat indistinct at times, but quite clarified at others. The interference that occurred and took the form of streaky light splashes was due to induction from the telegraph and telephone lines; but in spite of this the

(Continued on page 316)

# A SHORT COURSE IN TELEVISION

## Elementary Television Optics

By C. H. W. NASON,  
Television Engineer

### LESSON 4

**A**LL light takes the form of an electromagnetic manifestation; color is determined by the wavelength of the light. Since light may be definitely described in terms of *velocity*, *wavelength* and *frequency*, we may assume that it differs but slightly from radio waves in some respects. Light may be "monochromatic"—all of one color or wavelength—or, again, it may be composed of many colors.

#### Refraction

Let us suppose that a squad of men are advancing across hard ground into deep sand, their approach is on the diagonal. As they approach the hard-going, one man steps off ahead of the rest and, as the sand impedes him, the others crowd up. Those to the left as shown in Fig. 1, strike the sand an instant later and they also are impeded. Had they met the sand head on, the effect would merely have been one of crowding; as the rear men caught up with those slowing down. The fact that they approach at a diagonal results in a turning of the column. A similar effect will occur as they cross the sand and reach hard ground once again.

#### Why Light Rays Bend

A beam of light passing from one medium to another of denser character, has its motion slowed up, and, in striking

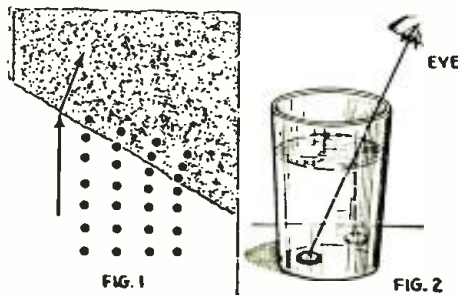

Optical diagrams showing at Fig. 1, effect of light beam passing from one medium to another of denser character, and at Fig. 2, simple demonstration of effect with coin in a glass of water

ing at an angle the wave front is bent in the manner shown in the case of the men. Place a coin in the bottom of a glass of water, as in Fig. 2; view it from all angles, and see how it is deceptive as to its position beneath the surface. The water does not seem quite so deep as it actually is. In entering a denser medium, light is bent toward the "normal" (the line perpendicular to the surface of the medium at that point), while in leaving it is bent away from the normal. This is shown in Fig. 3, from which it may be seen that, where the surfaces are parallel, the rays leaving and entering are parallel.

By the use of a *prism* we can deflect the ray; so that it will not be parallel

to its original course when leaving the denser medium. In all cases, the angle through which the ray is bent or refracted is determined by the substance it is traversing, and the degree of this effect is known as the *index of refraction* of the material. This index is different for different wavelengths of light; and thus the ray is split into its different color constituents, the manner is shown in Fig. 4.

#### The Lens

Let us consider a pair of prisms as shown in Fig. 5, cemented together at their bases. Note that the rays entering the structure are bent so that, upon leaving, they converge and are brought together at F. This constitutes an elementary lens; and the distance between the center of the lens and the *focal point* F is called the *focal length*. An entirely equivalent structure would be the lens shown in Fig. 6; this type of lens is termed double-convex. We have, according to their curvatures, the lenses shown in Fig. 7; from left to right respectively, the double-convex, plano-convex, concavo-convex, double-concave; plano-concave and concavo-concave. Draw lines *normal* to these surfaces, and see what the effect would be on a ray traversing one of these lenses. You will remember that the index of refraction is not the same for all colors; and it therefore holds that, with a lens, the

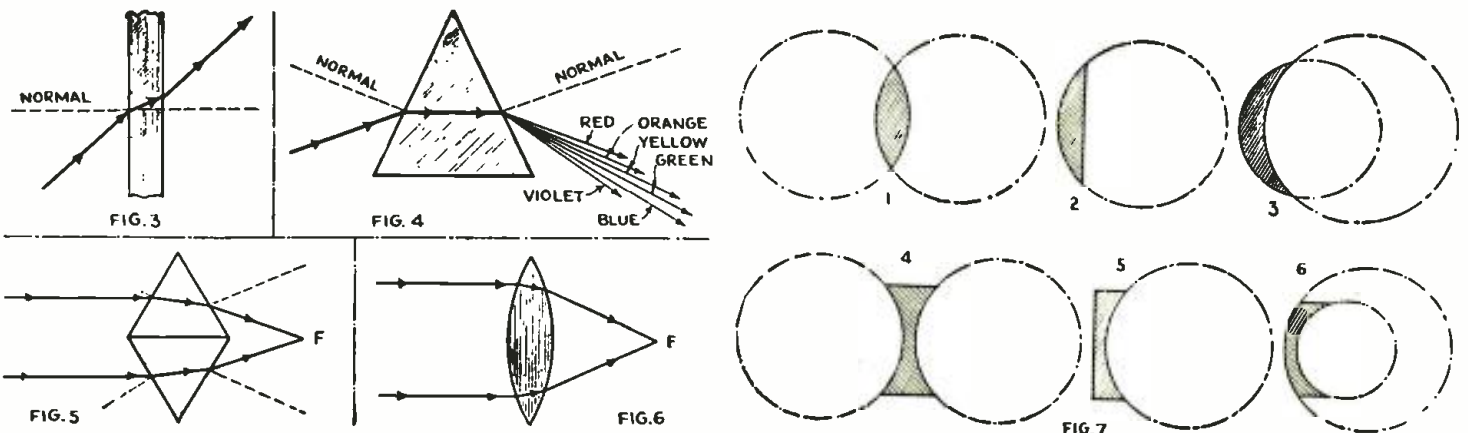

Diagrams above at left show bending of beam of light, as it passes through glass prisms and lenses of different shapes. Illustration at right, Fig. 7, shows development of various shaped lenses from double convex to concave-concave.

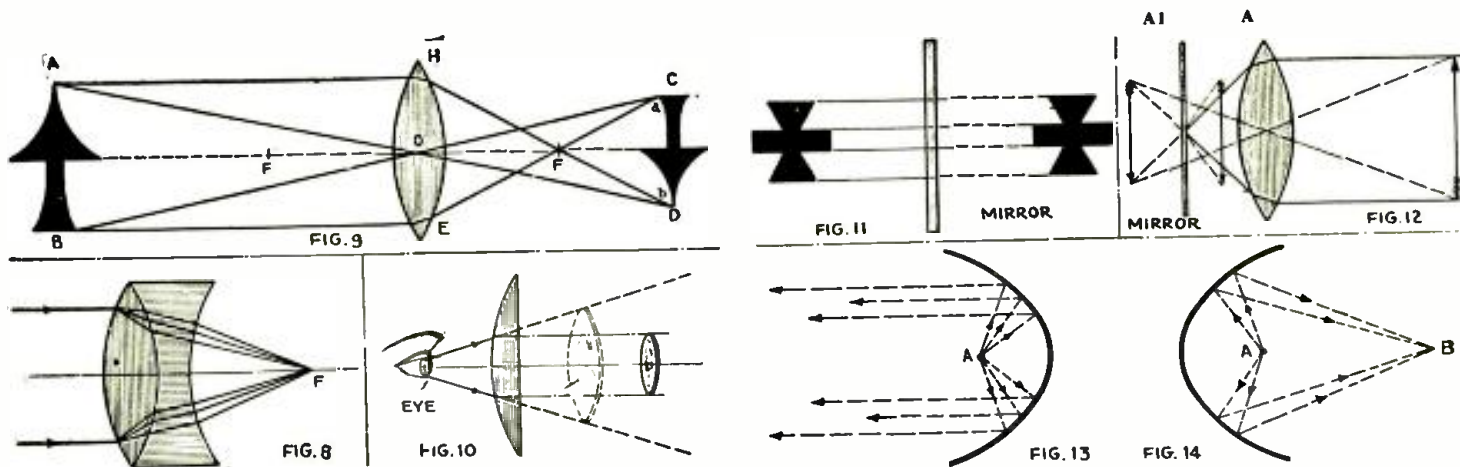

Fig. 9 shows how optical image is transmitted and reversed when passing through lens; the action of beam of light in passing through other shaped lenses is shown in Figs. 8 and 10; and theoretical optical action of mirrors at Figs. 11 to 14. Mirrors shown at 13 and 14 are of parabolic and elliptical shapes respectively.

focus will not be the same for all colors. Such color discrimination is called chromatic aberration. In high-quality optical instruments, this is compensated for by the use of lenses made from two types of glass, which have indices of refraction varying with color in equal and opposite senses. This is shown quite graphically in Fig. 8.

**Formation of An Image**

The formation of an image is accomplished by the means illustrated in Fig. 9; here AB is the object of which we desire to form the image at CD. The junction points *a* and *b* define both the position of the image and its size. The relations between focal length, size, distance, etc., must be taken into account in the calculations. These are not necessary for our purpose and can be obtained from any physics book.

It may be seen by a return to Fig. 1 that the lens will magnify. In Fig. 10 it becomes clear that the rays reaching the eye through the lens have been bent; and they appear to the eye as having taken the course indicated by the dotted lines. This gives the impression of increased size and decreased distance.

The two lines establish the position of the image. In photography, it is essential that details such as these be known, in order that the film may be

so situated with respect to the lens as to receive the image.

**The Magnifying Glass**

It may be seen from Fig. 2, that the rays might be so bent as to make the size of the coin apparently larger. The sketch in Fig. 10 shows how the rays reaching the eye are bent; and how their continuation, out along the dotted lines, gives the impression of an increased size, coincident with an apparent decrease in distance.

In television, it is desirable to increase the apparent size of the image as seen at the scanning disc. The size of the image as viewed through the lens is dependent upon many factors; the curvature of the lens (its focal length), the distances between the lens, the object and the eye all enter into the problem. To simplify matters, we may say arbitrarily that for a disc of average characteristics a 6-inch lens with a focal length of 20 inches, placed about 5 inches from the disc, will give satisfactory results. Attempts to gain a further enlargement of the image, through the use of a lens having a shorter focal length (greater curvature), will result in distortion of the image at the edges, such as to make the increased magnification valueless.

**Reflection Mirrors**

The law of reflection, applied to mirrors, states that the angle which

the main or incident ray makes with the normal line through the mirror, is the same as the angle of the reflected ray. This holds for plane surfaces as shown in Fig. 11, where it may be seen that the image is apparently as far behind the mirror as the true object is before it. (The law holds for curved mirrors, also, as we shall see.) A converging or diverging beam incident upon a mirror follows its normal law as well as the law of reflection. The system shown in Fig. 12, with a mirror at the focal point, would result in an image apparently at A', but really formed at A. Interposition of a plane mirror in an optical system has then no effect other than the change of position upon the optical structure.

Of course mirrors may have curvature; and a mirror such as that shown in Fig. 13 (known as a parabolic mirror) reflects rays from the source "A" (its focal point) all in a single parallel beam; whereas an elliptical mirror, such as shown in Fig. 14, concentrates the rays from a point "A" at another point "B" (its focal point).

Scanning systems employing plane mirrors are numerous and it should be remembered that they affect a change in direction only, as was the case with the prism. In fact lenses, prisms, mirrors and all may become parts of the television optical system, as we shall later see.

**Y. M. C. A. Television Course Ready**

**A**DDITIONAL evidence, that television is rapidly coming to the point of practical use, is seen in the announcement of the New York City Y. M. C. A. that a West Side Y. M. C. A. Radio-Television Institute, at 5 West 63rd Street, to train television technicians, is to be inaugurated in the new Educational Building of this institution in September. This new television educational enterprise will be started in response to the demand from young men, who see promising futures in this infant industry,

and who wish to get in on the ground floor.

"Television is now in the same experimental stage as sound technique was when broadcasting first started—crude but with a very promising future", according to Louis L. Credner, principal of the West Side Y. M. C. A. trade and technical schools. "Television, at present, compares favorably with the ear-phone stage of the early days of radio reception, when crystal detectors and one-tube receivers were being used; it offers un-

limited opportunities for further experimentation. The young man of far-reaching vision can tie his future to this industry and feel that progress will come rapidly. Radio was such a field, and now the same kind of opportunity presents itself in the new art of television.

"Just what the future of this new art will be, depends upon further extensive research and engineering, with close cooperation between laboratory engineers, radio amateurs and, es-

(Continued on page 312)

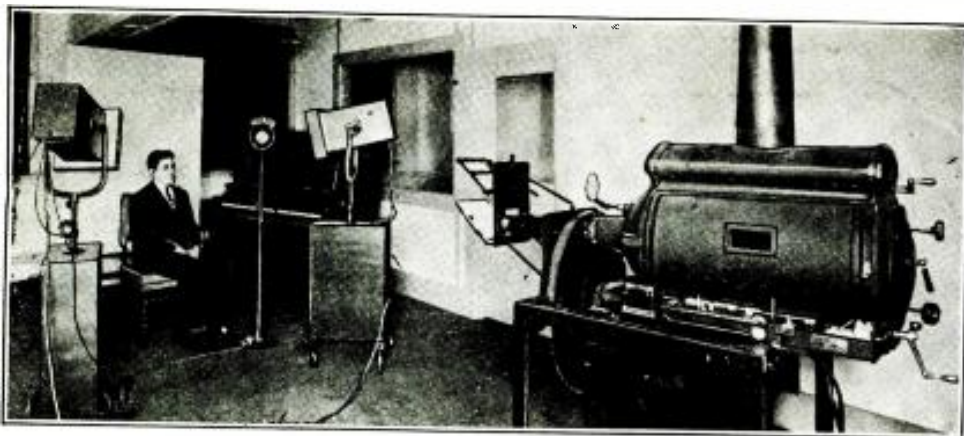

Q What does the "Control Operator" do in a television studio?

Q What are the duties of the "Radio and Film Pickup" Operator?

Q What does the "Direct Pickup" Operator do?

Q The "Announcer and Studio Director"—what are his exacting duties?

These and many other little-known points are explained by Mr. Du Mont.

The "flying spot" pickup previously used at Passaic, now superseded by "direct pickup" camera.

# Practical Operation of a COMPLETE TELEVISION SYSTEM\*

By ALLEN B. DU MONT  
Vice-President and Chief Engineer  
De Forest Radio Company

IN this paper a practical system for accomplishing radio television or radiovision will be described. Before going into details, however, it might be well to state the general problems and to give a brief résumé of the inventions which have made a practical television system possible.

### Analyzing the Image

To start with, we must have a suitable method of analyzing the event to be transmitted. The most satisfactory method for this purpose at present makes use of the Nipkow disc (invented by Nipkow in 1884), in which a number of holes are punched to form a spiral. The disc is mounted on the shaft of a motor. For picking up outdoor events, where the intensity of illumination is considerable, the image is usually focused on the disc by means of lenses, so that it may be analyzed in its reduced form. For studio pickups, however, it is generally advantageous to reverse this process. Instead of focusing the image on the disc, a powerful beam of light, properly guided by the disc, is projected on the subject to be analyzed. The lenses in front of the disc may be shifted to take care of a larger or smaller field; while the adjustable mirrors in front of the lenses permit of shifting the light beam up or down for any desired height of subject.

### Translating Light Waves Into Electrical Impulses

After the event has been analyzed, it is necessary to translate the varying light waves picked up, into varying electrical impulses. This translation is accomplished by means of a light-sensitive or photoelectric cell. As the light waves fall on the cell, the current passing through the cell is proportionately varied.

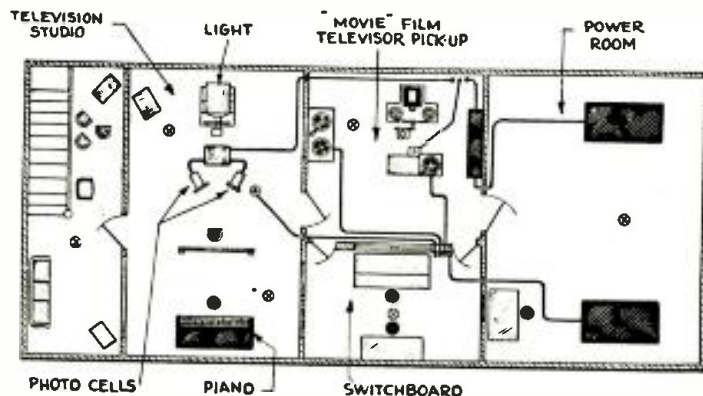

Floor plan layout of typical television studio, including film pickup room, control switchboard and power rooms. The studio is here shown with "flying spot" and photo cell pickup.

Going back a bit in our television history, it is interesting to note that only as recently as the past five years have suitable photoelectric cells been available. For television work, the photoelectric cells must be sufficiently sensitive and possess a satisfactory frequency response. Prior to five years ago, the available photoelectric cells were either too sluggish to transform

faithfully the high-frequency light variations into corresponding electric variations, or they lacked the necessary sensitivity. At present the Potassium Hydride Cell and the Caesium Sub-Oxide Cell are available for this work and, while by no means the ultimate cells, they are successfully employed with proper associated apparatus. We are now employing the De-

Seems intricate, but this control panel devised by the de Forest engineers, is quite readily mastered by the television experts in charge of the broadcasting at W2XCD, Passaic, N. J.

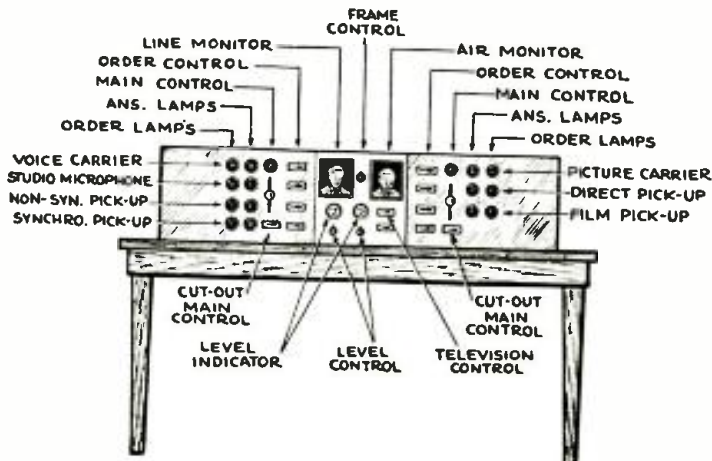

\* Paper read before Radio Club of America.

Forest "Type 668" photoelectric cells of the Caesium Sub-Oxide type in our work.

**Amplifying the Photo-Cell Currents**

Having obtained weak electrical variations as the result of our light-translation process, it is now necessary to amplify those variations several million times without distortion. This step is accomplished by a carefully designed resistance-coupled amplifier employing a number of Audions (vacuum tubes). It is hardly necessary to state here that the invention of the Audion or three-element tube, in 1906, by Dr. Lee DeForest, has made possible the amplifying of weak currents to almost any desired value. After the electrical variations are amplified, they are put to work modulating or regulating a radio transmitter which is similar to the usual broadcast transmitter, but designed to pass the far wider band of frequencies required for good pictorial detail in television work.

artists who are to appear before the direct pickup camera. In this room a *Radiovisor* or "looking-in" device is provided so that the artists may see for themselves the programs on the air and how they are being received. Looking through a window on one side of the reception room, the artists and studio visitors may see the other artists as they are being televised. A loud speaker is also installed in this room, and operated by the voice transmitter.

**The Direct Pick-up Studio**

Adjoining the reception room is the direct pick-up studio. As the voices as well as the actions of the artists must be picked up in this studio, the treatment is along the same acoustic lines as that of a modern sound-broadcast studio. The "flying-spot" pickup apparatus as well as the two photoelectric cell units are very much in evidence.

Each photo-cell unit comprises four photoelectric cells, mounted on cush-

mities. It might be well to state at this point that extreme care must be taken in the layout of the unit to prevent microphonics. We have found that, in addition to the cushioned supports of the photo-cell, sound-absorbing material behind the photo-cell mounting helps considerably. If only the picture is being transmitted, without sounds to contend with, no difficulty is experienced with microphonics.

The flying-spot pick-up makes use of a 3.7 kw. arc mounted on a movable stand, together with the scanning disc and motor. As already mentioned, several lenses make possible the televising of either close-up or long shots. Mirrors in front of the lenses enable the operator to shift the scanning beam up or down, in following the artist in a close-up shot. The studio includes a radiovisor; so that an artist or the pickup operator may occasionally "look in" and check up on the program being transmitted.

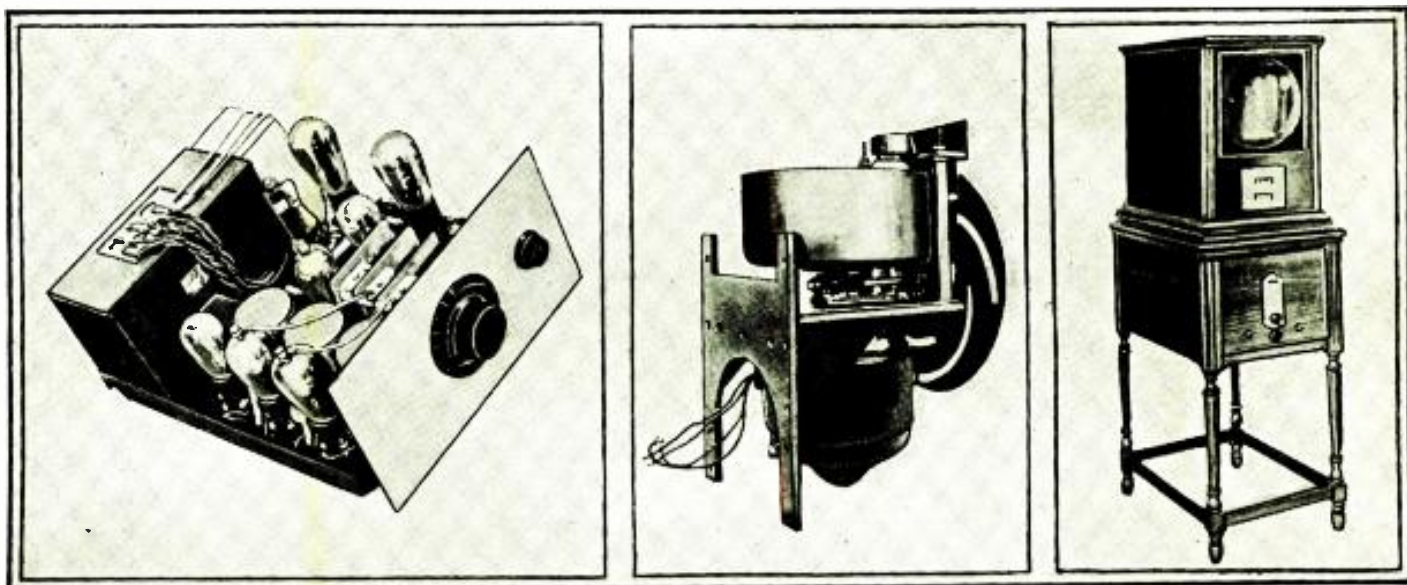

Left: Jenkins television receiver. Center: Spiral scanning shutter and hole drum, both of which are rotated by the synchronous motor. Right: Large Jenkins radiovisor in which both of the mechanisms shown at left and center are incorporated. Image is observed through the large lens.

We have, so far, briefly discussed the method employed in picking up the event and starting it on its way through the ether. No mention has been made of the voice or sound pick-up apparatus, so frequently employed in combination with television programs; but, since such apparatus is quite similar to that employed in sound broadcasting work, no further mention is required.

**W2XCD—Layout of Transmission Studio**

In order to visualize the layout of a sight and sound television transmitter, we refer to one of the illustrations herewith, depicting the direct pick-up studio, W2XCD of the DeForest Company at Passaic, N. J.

Referring to the floor plan, we note that a reception room is provided for

ioned supports, and placed at the focal point of individual spherical mirrors that collect and concentrate the reflected light from the subject. As an integral part of the unit, there is the "head amplifier," which amplifies the current from the photoelectric cells and feeds it to the main picture amplifier. The main purpose of the "head amplifier" is to raise the level of the current from the photo-cells until the ratio between this current and any extraneous or parasitic currents will be such as to overcome any streaks or lines in the picture. The photo-cell pickup units are mounted on rubber-tired wheels, so that they may be moved about readily. Also, the mounting is such that they may be raised or lowered to follow the artist. The photo-cells are screened electrically to prevent any feed-back from the trans-

**Where "Sound" and "Films" Are Picked Up**

Next to the *direct pickup studio* is the *mechanical pickup room*, containing the *film-pickup apparatus* and the *synchronized sound accompaniment*. A non-synchronous sound pickup is also provided and is employed when films without their own sound are being transmitted.

The main picture amplifier is also in this room. This amplifier takes the signal either from the direct pickup head amplifiers or the film pickup amplifiers, and increases it to feed directly into the modulator tube of the transmitter. The head and main amplifiers have a practically flat characteristic from 15 to 100,000 cycles. The main picture amplifier increases the voltage of the incoming signal approximately 2,000,000 times.

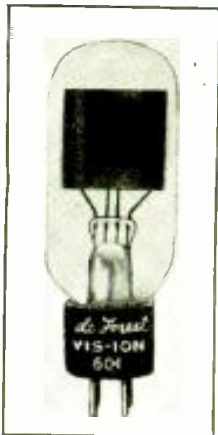

Left: de Forest "Vision" tube; really a neon tube with square plate, which is placed behind the scanning disc at the receiver.

Center: Film and voice (record) pickup combined in one machine. The film scanner is at the left of the machine.

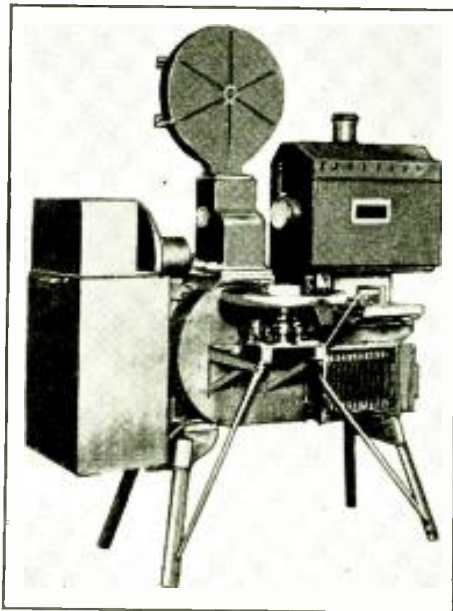

(7) Keep sound or voice level constant.  
(8) Shift from films to direct pickup.  
(9) Shift from microphone to phonograph or synchronous phonograph turntable.

#### Radio and Film Pickup Operator

- (1) Check operation of picture transmitter.
- (2) Check operation of voice transmitter.
- (3) Operate film pickup.
- (4) Change phonograph records.
- (5) Operate synchronous record drive.
- (6) Keep film pickup in focus.

#### Direct Pickup Operator

- (1) Keep artists in field of direct pickup.
- (2) Keep direct pickup in focus.
- (3) Keep photo-cell units adjusted.
- (4) Check arc and change carbons.

#### Announcer and Studio Director

- (1) Make announcements.
- (2) Instruct artists.
- (3) Locate artists and instruments.
- (4) Have acts ready to go on.
- (5) Shift properties.

It will be noted that there are twenty-four duties listed. Nine of these duties are necessary in sound-broadcast operation, namely; monitor voice for quality; keep voice level constant; check operation of voice transmitter; change phonograph records; make announcements; instruct artists; locate artists and instruments; have acts ready to go on; and shift properties. It will also be noted that the control operator must keep the other operators informed as to what is going on and what is desired, so that the program may move along without a hitch.

#### Double Television Monitor Used

The control panel consists of two televisions employed as *monitors*, for both the picture on the line and the picture on the air. Beneath the *line monitor* is a *level indicator*; and beneath this is a level control for the picture over the line. By varying the *level control*, the signal to the modulator tubes is varied. Beneath the *air monitor* are switches to turn "on" or "off" the televisions. Between the *air* and *line monitors* is a "frame control," which is simply a switch controlling the scanning motor on the film-drive. In order that our "lookers-

Small de Forest photo-cell, fitted with standard tube base, which makes it handy to use for all experimental and other work. These small cells are widely used now by placing them in the focus of a reflector, instead of the expensive large-diameter photo-cells, which are very expensive.

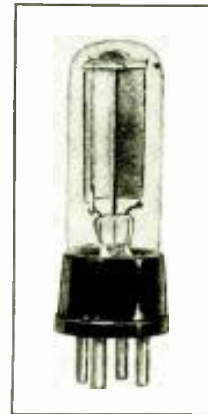

in" may only have to frame the picture once, we start our direct pickup scanning apparatus before the program starts; and allow it to run throughout the program. The air and line monitors are then framed by snapping "on" and "off" the switches under the air monitor until they are in frame. We now have both monitors in synchronization with the direct pickup scanner; and they are bound to stay in step until the station is closed down, following the completion of the program.

When we shift from direct pickup to films, the *frame control* between *air* and *line* monitors is turned on and off until the picture is "framed"; before the picture is put on the air. This calls for one adjustment at the studio, instead of an individual adjustment at each receiving location.

#### Voice Control

Beneath the frame control is the *voice-level indicator*, and beneath this is the *voice-level control*. To the left of the central panel just described is the voice-control panel. The four divisions vertically are, in turn: the order control; the main control; the order lamps; and the answer lamps. The same arrangement also applies to the picture control, which is to the right of the control panel. With regard to the voice controls, the four divisions horizontally are, in turn: the *voice carrier*; the *studio microphone*; the *non-synchronous pickup*, and the *synchronous pickup*.

On the picture controls the three divisions are, in turn: the *picture carrier*, the *flying-spot pickup*, and the *film pickup*. This control arrangement enables the control operator to direct and to monitor the programs. He can indicate to the various operators what is desired, and he is notified when the order has been carried out. Signal lights in the three rooms notify the operators what is desired and also what is going on.

While further improvements are being made in the control room, the arrangement referred to has proved satisfactory in maintaining a smooth flow of program features. So much for the *transmitting equipment*.

(Continued on page 316)

In the film pickup apparatus, the film feeds through continuously, that is, without the intermittent motion of the usual motion picture projector. The holes in the scanning disc are arranged in the form of a circle rather than as a spiral. At present we are employing "sound on disc"; but a new film pickup has been designed and is being built, which will permit us to employ either "sound on film" or "sound on disc" presentations. Also, at the present time, it is necessary to employ special records, because all records available are for 24 pictures a second, whereas we are transmitting only 15 pictures per second. Our new pickup is so designed that standard 24-picture-per-second recordings can be run through at any desired speed, for perfectly synchronized sight and sound presentations.

The voice and the picture transmitters are contained in a separate room adjacent to the film pickup room. Special precautions have been taken to prevent modulation of the voice transmitter by the picture transmitter, or vice versa. The picture transmitter operates on a frequency of 2,035 kc., and the voice transmitter on a frequency of 1,604 kc.

#### The Transmitter Control Room

The control room is so located as to face the three rooms already mentioned, namely, the direct pickup studio, the film pickup room, and the transmitter room. Windows are provided, so that the control-room operator can see into each room at all times.

In front of the control-room operator is a *control board*, shown in one of the accompanying illustrations. Before describing the apparatus in this room, it might be well to point out the greater number of details to be watched in the radiovision station, as compared with the usual sound broadcaster. Following are the duties of the various operators at Station W2XCD.

#### Control Operator

- (1) Monitor picture over line for quality.
- (2) Keep picture level constant.
- (3) Synchronize film and direct pickup.
- (4) See that films and sounds are synchronized.
- (5) Monitor pictures over line for quality.
- (6) Monitor sound or voice for quality.

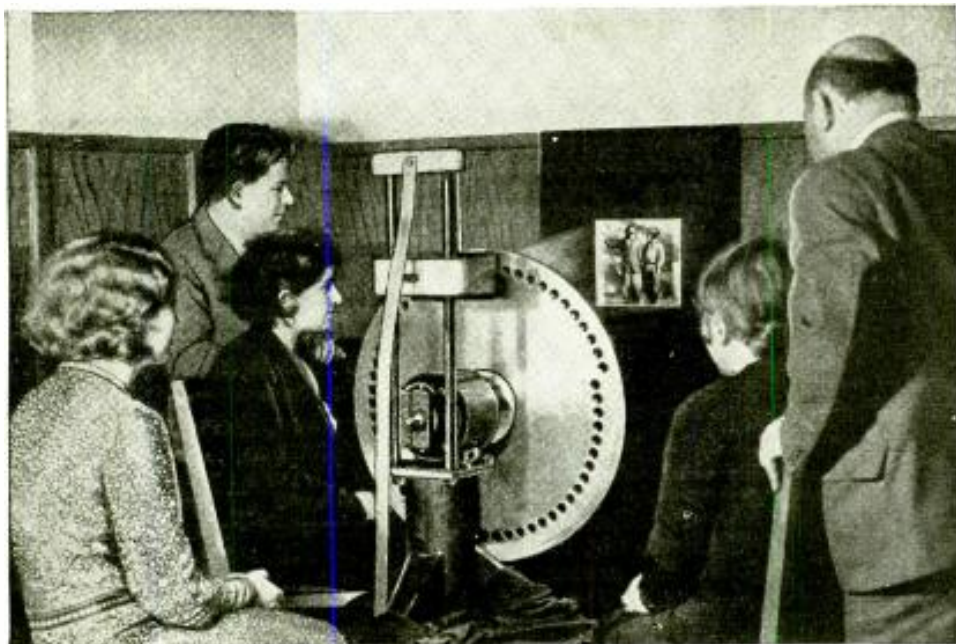

What's around the corner? We mean, of course, the "Television Corner." This glimpse behind the scenes of a modern television laboratory obtained by Mr. Fitch will give you some idea of what to expect in new "Fall styles" in Televisors. For one thing, if the family is to enjoy television, some form of "projector" will be necessary—nay — practically imperative. Such a projector is described here by Mr. Fitch, television and short wave expert.

New "I. C. A." crater tube and lens disc television projector for home use.

# Behind Closed Doors

## In a Modern Television Laboratory

By CLYDE J. FITCH

"AN inexpensive televisor that will throw a picture about one foot square will be available for home use this fall," is a statement made to me by Mr. A. G. Heller, Chief Engineer of the Insuline Corp. of America. Having followed the developments of television for some time, and gathered together all the available literature on the subject, such as newspaper clippings, magazine articles, books and what-nots, my curiosity was still unsatisfied; for, while the various writers give details of the generally known systems, when it comes to the latest developments, they invariably wind up by stating "We don't know what is going on behind closed doors."

### An 8-Inch Image From a 6-Inch Disc

It was to find out what was going on behind closed doors that caused me to visit my old friend, Mr. Heller. Knowing Mr. Heller to be a man of a very progressive nature, he, certainly, would be "on his toes" when it came to this newest art, *television*. And he certainly was. Seated behind his desk at the Company's new spacious headquarters at 23-25 Park Place, New York, he received me with a hearty welcome; and, as soon as I made known the nature of my visit, with a broad smile, he opened his desk drawer and pulled out a 60-hole scanning disc no larger than a saucer! It might have been six inches in diameter, to be more exact. "This

midget televisor," he said, "will project an image up to eight inches square. We also have a new type of *lens-disc scanner that will project an image up to two feet square*, and an entirely new type of televisor that will give a full-size moving-picture screen image of great brilliancy suitable for use in the largest theaters."

My curiosity was aroused. "How do you get an eight-inch image from a six-inch disc?" I inquired, knowing that it requires a 30-inch disc to obtain an image about 1½ inches square, without magnification.

### Into the Laboratory

"Come into the laboratory and see for yourself," he replied. So we walked through the corridors until we came to a closed door marked "TELEVISION LABORATORIES," and we entered. Inside was a large room filled with all sorts of miscellaneous laboratory testing instruments, vacuum tubes, lamps, lenses, projectors, etc. It looked like a combined radio and optical laboratory, with some motion-picture apparatus thrown in.

In the adjoining room was a complete television studio. Mr. Heller transmits his own television images, for demonstration and testing purposes, so that he can demonstrate his various television receivers at any time and is not dependent upon the

regular broadcast-image programs; although these programs are made use of when available for the more skeptical spectators. It was this apparatus that he used to demonstrate his various laboratory models and convince me of the authenticity of his statements. Standard motion-picture film is run through the transmitting apparatus, and the television signals are transferred by wire or radio to the televisors in the laboratory. It is by such means that Mr. Heller was able to conduct his exhaustive researches and perfect his various image receiving instruments, without being hampered by the lack of suitable programs for testing purposes, which has indeed handicapped many television experimenters.

### The Midget Televisor

The *midget televisor* appealed to me. Midget radio sets have taken the country by storm, and midget televisors will probably follow in their footsteps. No one wants in their home a large machine shop that will give merely a "peep-hole" view of the image, which only one person can see at a time. Here is a miniature instrument that projects an image up to eight inches square, with sufficient brilliancy to be seen across the room by a dozen or more persons. Basically, it operates the same as other televisors, but has reached a finer de-

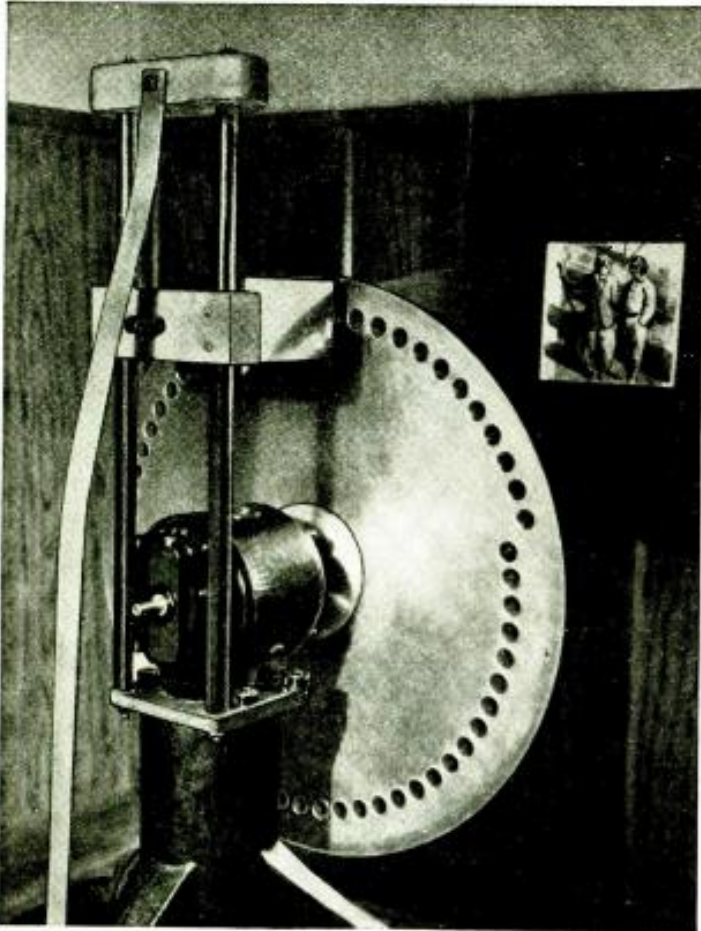

*Lens scanning disc and neon "crater" tube image projector, the disc being rotated by a synchronous motor. Each hole in the disc has a lens fitted in it. The crater tube is inside the box just behind the disc.*

gree of perfection. Fig. 1 shows the principles involved.

In this illustration (which is diagrammatic only) the image signal coming from the television receiver is fed into a neon crater lamp. This lamp looks like an ordinary vacuum tube, but it gives out an intensely brilliant spot of light, at the top, which varies in exact accordance with the pulsations of the image current.

The light from this lamp is passed through a set of condensing lenses which cause it to diverge slightly; so that, when reflected by the mirror and projected on to the small scanning disc, which is driven at synchronous speed by means of a small electric motor, it covers an area equal in size to the very small image frame of the disc—about 1/4-inch square. At this point, on the surface of the disc, a very brilliant small-sized image would appear, if one looked at the light through the disc.

Light from the small disc image is then passed through a set of focusing lenses and projected, in the same manner that a moving-picture image is projected, on to a viewing screen. The limitations in size of the screen depend upon the amount of light available. With this small apparatus, the upper limit in size is about 8 inches square; or, to be more exact, about 8 inches high and 9 1/2 inches wide, or in the ratio of 5 to 6.

**New Compact Television Receiver**

Following along the same path of development with the midget televisior

is a new midget television receiver. At the time Mr. Heller showed this to me, it was in the process of construction and consequently full details are not available as yet; but the circuit employed is somewhat standard, except that a pentode output tube is used—it being characteristic of Mr. Heller to use the newest types of tubes with his apparatus.

Work was then in progress on the design of a special means for coupling the pentode to the neon lamp, so that the impedances would be correctly matched and clear images obtained. So far, little has been done along this line by television manufacturers. They have simply inserted a neon tube of some 600 to 1000 ohms impedance in the output circuit of a power tube, having an impedance of some 2000 ohms, and trusted to luck that images would be recognizable. Data on this new receiver will be available shortly.

**The Lens Disc**

There is nothing new in the use of a lens disc scanner. It is the same as

the ordinary scanning disc but, instead of a number of small holes, it makes use of a number of lenses. In this way considerably more light is gathered from the neon crater lamp, and the illumination is sufficient to be projected on to a screen up to two feet square. The difference between a lens disc and a hole disc is about the same as the difference between a pinhole camera and a lens-type camera—one requires an exposure of three or four minutes to take a picture, while the other can take it in one-hundredth of a second or less.

The lens disc, therefore, gives much brighter pictures. It has not come into general use as yet, because of the enormous cost of producing them. This is apparent from the illustration of Fig. 2, which is a cross-sectional view showing how the lens is mounted in the ordinary type of lens disc. A large hole is bored in the disc, which is counterbored to a depth a little greater than the thickness of the lens. The lens is fitted in place and the edge then spun over to hold it. It is obvious that a very thick and expensive disc is required in this construction, and the weight adds operating difficulties.

This problem was attacked and conquered by Mr. Heller, with the design shown in Fig. 3. Here a thin disc is employed. Each lens is fitted into a thin metal lens holder, which is forced into the holes on the disc, as shown. In this way the disc is made thin enough so that the holes can be punched instead of bored or drilled; and the cost of manufacture is greatly reduced, bringing the finished televisior down to a price within the reach of the average radio listener.

The lens scanners which I saw appeared to be about 26 inches in diameter and 1/16-inch thick. Sixty lenses were mounted on each disc, in the form of a spiral, as in the usual Nipkow scanning disc. The disc was made of aluminum and driven by a synchronous motor. This method of driving a disc is used when the re-

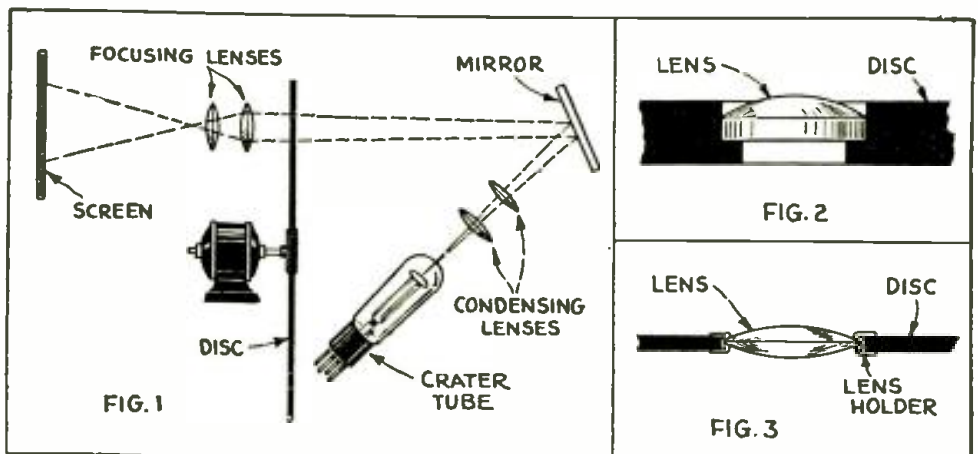

*Fig. 1—Optical system comprising lenses, scanning disc, mirror and crater tube in the new I. C. A. television image receiver. Fig. 2—Shows mounting of lens in a thick scanning disc and, Fig. 3, how lens is held in a thin scanning disc.*



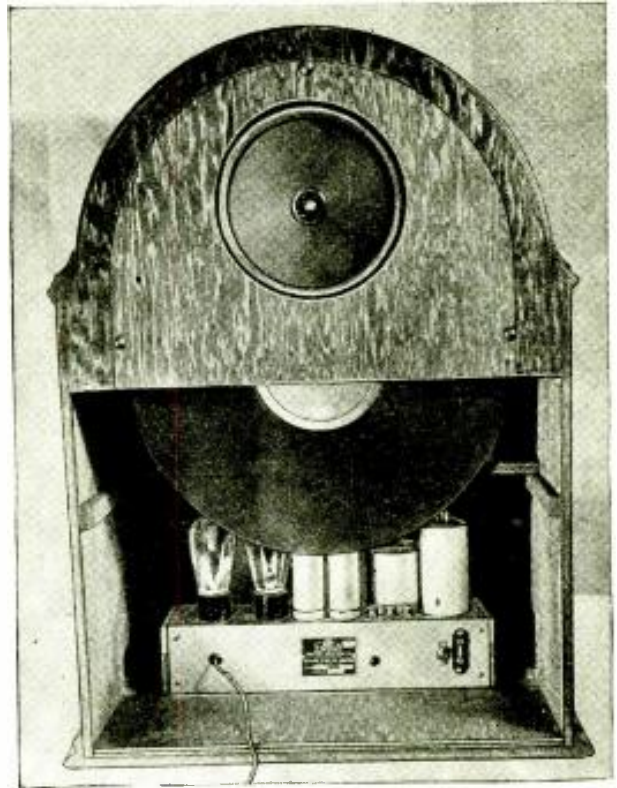
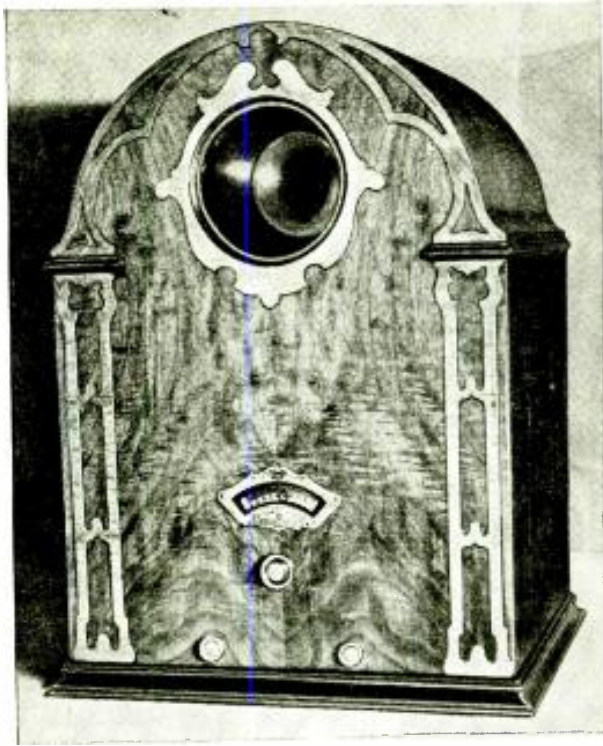

Appearance of the newest model I. C. A. home television scanner, with short wave receiver and amplifier. A dynamic loud speaker is mounted in the rear top panel, as photo at right shows.

ceiver is operated from the same electric lighting supply as that which feeds the transmitting apparatus. When it is operated from some other circuit, a special synchronizing device is employed. This takes the form of a small synchronous motor driven by the fundamental image-signal frequency, which is determined by the number of scanning holes which pass by the image each second. In a 60-hole disc, transmitting 20 images a second, this frequency is 60 times 20, or 1200 cycles.

The synchronizing motor, therefore, is merely a small 1200 R.P.M. synchronous motor mounted on the same shaft as the main driving motor. The driving motor brings the disc up to approximate synchronism, and the synchronous motor (also called phonic motor) brings the speed into synchronism with the transmitter and holds it in step—locking the speed so that no further adjustment is necessary.

Projection of the image from the lens disc is effected by the lenses themselves, as they pass in front of the neon crater lamp. The lenses have a  $4\frac{1}{2}$ -inch focus; and the lamp is, therefore, placed  $4\frac{1}{2}$  inches from the disc. All of the light is available all of the time—the lenses gathering the total amount and projecting it on the screen in the proper position; whereas in the hole-type disc, only the light that passes through the small hole is available. In other words, with an image 60 holes high and 72 holes wide (the 5-to-6 ratio of the picture now

used) 60 times 72 or 4320 times as much light is available with the lens disc. With the aid of the projecting lenses, this light will produce a large, two-foot image of a luminous intensity sufficient to be seen by a large audience. And the picture detail is exceptionally good.

Either the midget televisor or the lens-disc televisor may be used in connection with the television receiver now in the process of construction. Plans for the production of both outfits are well under way, and they will soon be available for home use. Demonstration facilities are also under way and a demonstration studio is now being prepared for public demonstrations. Just how soon the television apparatus will be ready for distribution is hard to say. As near as I could gather, everything was ready for production except the cabinets, and these should not take long.

#### The Giant Televisor

Having taken the liberty of calling the small televisor the midget, I now call the large moving-picture screen sized one the "Giant."

In projecting an image from either of the two televisors mentioned above, the limitations in the size of the picture is determined, as I have stated, by the amount of light available; the more light, the larger the image can be. By the system of lenses used, the size of the image may be changed at will, in the same manner that a small magic lantern or moving-picture image is projected. While, with the

smallest one, it might be best to project the image on a ground-glass screen, in the lens-disc type it can be projected directly on a wall, if desired. The room should preferably be darkened.

To get an image twice as large (four times the area) four times as much light is required. Each enlargement, of course, increases the size only, and does not make the image any more clearer in detail—a 60 line image remaining 60 lines, regardless of the size. Increasing the number of lines introduces more complications—too lengthy to be covered here. The Bell Laboratories now use 72 lines, and eventually all stations may come to that standard.

Since the projection of an image on a large moving-picture screen would require some hundred times as much light as is now obtained from the lens disc, I could conceive of no method whereby this large amount of light could be obtained; and, seeing no giant screen in the laboratory, I questioned Mr. Heller.

"We use a large number of lamps on the screen," said Mr. Heller. And he went on to describe the process, which consisted essentially of a screen made up of literally hundreds of electric lamps, somewhat like the large electric signs on Broadway. These lamp screens have been used before, both neon and electric lamps being employed. But they have been too complicated for general use. The use of a small filament-type lamp instead of

(Continued on page 305)

# Novel Photo RECORDER for Television

By P. P. DE WITT

An ingenious suggestion for a television transmitting and receiving system employing a special photo-film, the image being scanned and reproduced by means of cathode rays.

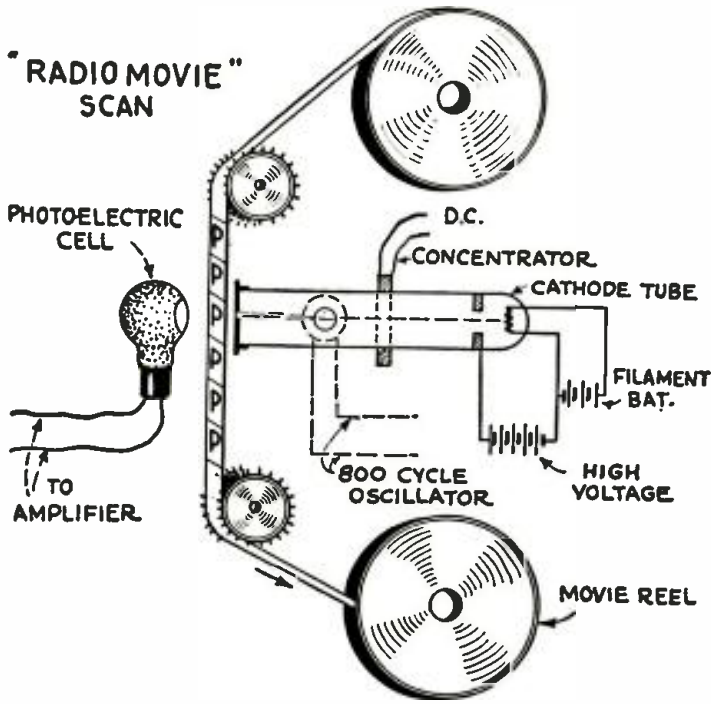

Diagram above shows transmitting scanner scheme where a cathode ray scans the image on the film and light fluctuations actuate the photoelectric cell.

**I**N the radio movie scanning system proposed by the writer, the movie negative is changed into a pulsating electric current to be amplified and transmitted.

This system is built around the cathode tube. The cathode stream is emitted from the cathode and is directed toward the photoelectric cell. In the end of the tube we find a brass cap with a window of aluminum foil; this window is about one hundredth of an inch wide and as long as the film is wide, about one inch. The brass is opaque to the cathode stream, but the aluminum is transparent. A vacuum is maintained in the tube.

A concentrating coil is used to make the cathode stream come to focus at the window; electromagnets actuated by an 800-cycle oscillator drive the stream across the window, to and fro, 800 times per second.

The film is driven past the end of the tube at the rate of 16 pictures per second at a constant speed. Silver and other heavy metals are opaque to the ray and, as the film passes with its varying amounts of silver deposits that make up the negative, the cathode stream is made variable and a pulsating output of the photocell is the result.

In the radio-movie receiving system, the modulated carrier wave is changed into a negative on a film that can be projected on a screen.

In the receiver the cathode tube plays the same important part as in the transmitter. Here the output of a radio receiver is used to make the cathode stream variable, by a grid-like arrangement in the tube. This variable stream is brought to focus on the film through the window in the cathode tube. This film, which advances

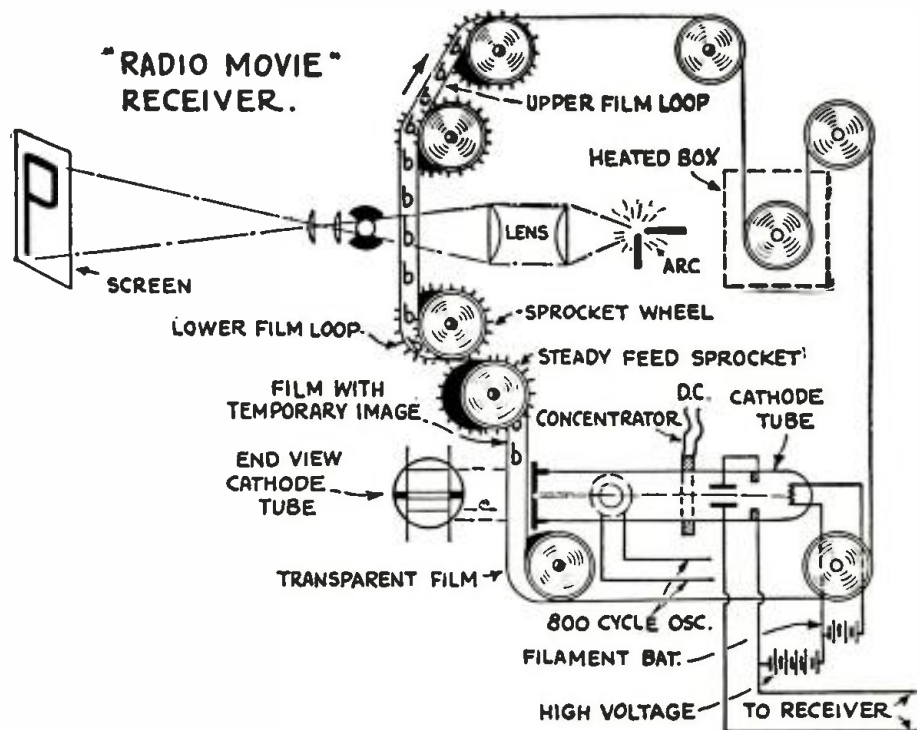

Above we have Mr. De Witt's television receiver using special film. the cathode ray building up the picture on the film, such as the letter (b), the image being removed from the film by passing it through the heated box.

**WE WILL PAY**  
For Good Articles Describing  
**WORKABLE TELEVISION**  
**RECEIVERS AND SCANNERS**

at the same rate as the one at the transmitter, is coated with a substance which is affected by the cathode stream, and a temporary negative is built up on it. The cathode tube in the receiver must scan in perfect syn-

chronism with that at the transmitter.

The variable cathode stream makes a temporary negative on the film as it passes the narrow window. This is retained until it has time to pass the film gate of the movie projector, and the image of desired screens is produced on the screen. The negative image is only temporary and is made to disappear in the heated box, so that the same film is kept in continuous use.

IT is not the intention of the editors to make this section a mere *Patent Digest*; for much has gone before that is of interest to those newly interested in the art. In each issue of TELEVISION NEWS there will appear a group of patents chosen, not for their recent date of issue, but for their general interest and for their practicability from the point of view of the amateur enthusiast and the independent investigator. Patents chosen for publication will be first rated according to their general interest and value to the group to which this publication caters. Those lacking in value will be commented upon, for the benefit of those interested in securing a full digest of the patents in this field.

# Digest of Television Patents

The essence of valuable and interesting television patents extracted for you by an expert.

makes the monitor image observable at one side of the person being scanned. A second optical system may be provided for orienting the image in the correct sense, to make it visible in the upright position.

### Synchronizing Motor

No. 1778674, issued to Ray D. Kell, Assignor to the General Electric Co. Patented October 14, 1930.

An apparatus for the transmission of pictures.

This particular patent is of extreme interest, for the arrangement is adaptable to the needs of the home constructor. The disc is driven by a series motor which serves to take up the windage and frictional losses and

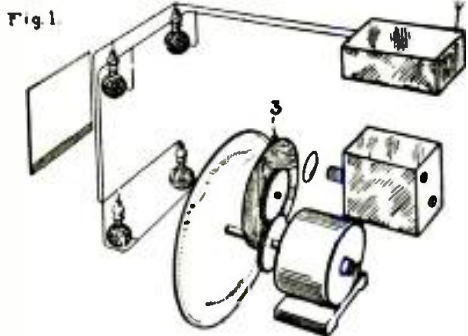

Fig. 1  
A light filter "3" and a double spiral disc are used to produce television images in color.

### Color Television

No. 1748883, issued to Ray D. Kell, Assignor to the General Electric Co. Patented February 25, 1930.

This patent relates to a method for transmitting television images in color.

A scanning system employing the "flying spot" method has a scanning disc provided with two separate spirals. During the traverse of the field by one spiral the light is of one color—during the second scanning of each revolution the light is of a second color. A light filter (3) interposed between the light spot and the disc accomplishes this, by means of suitable gearing, as shown in the figure. The reflected light from the scene is picked up by a bank of photo tubes, and the resulting variations are used to modulate a radio transmitter. These signals are picked up by a receiving set of suitable characteristics and fed to a pair of gas-discharge tubes, having color characteristics similar to the

light which played on the scene during alternate scanings. A commutator on the shaft of the motor driving the receiving disc serves to connect into circuit the proper discharge tube for complete synchronization of the system, both as to timing and color. The scanning is at a sufficiently rapid rate for the effect of persistence of vision to give the effect of a two-color half-tone. This system is adaptable to present methods of television transmission without any undue changes in the equipment used.

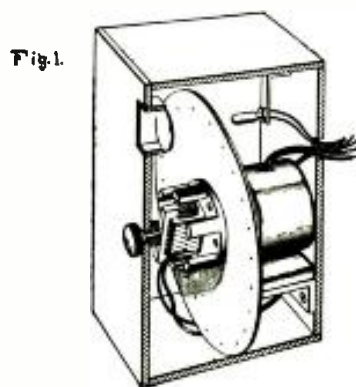

Fig. 1  
Novel design of synchronizing motor, the rotor of which is attached to the scanning disc, while the stator is fixed to the front panel of the cabinet, so that it can be turned by hand for "framing" the picture.

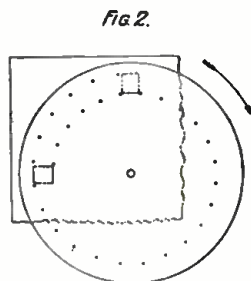
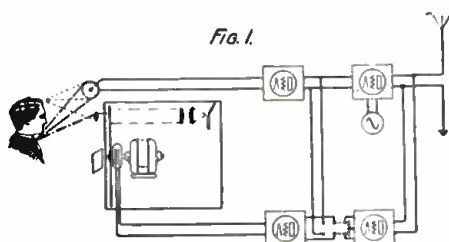

Fig. 1  
An improved method for monitoring the output of a television amplifier. A prism rectifying the side-wise image.

### Transmission Monitor

No. 1717782, issued to Herbert E. Ives, and Joseph W. Horton, Assignors to the Bell Telephone Laboratories, Inc. Patented June 18, 1929.

A method for monitoring the output of a television amplifier. Here the transmitting disc has a neon tube placed at one side and fed by a portion of the output of the transmitting amplifier. This image is produced with its left side downward and its top toward the observers left. A prism

to maintain the disc in rotation. A small synchronous motor comprising a stator carrying A.C. of the same frequency as the supply driving the synchronous motor at the transmitting point, is mounted in the manner shown in the diagram. The rotor is attached directly to the disc; while the stator is fixed to the front panel of the cabinet, in such a manner that it may be rotated by hand for phasing or framing the picture. This synchronous motor carries only the burden of speed control, and is not required to pull the load of the disc. This is similar to a device now on the market, and is well within the ability of the amateur.

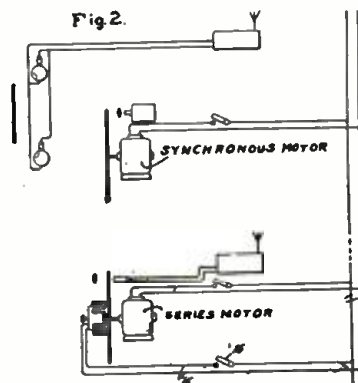

Fig. 2  
Diagram showing how special synchronizing motor is connected.

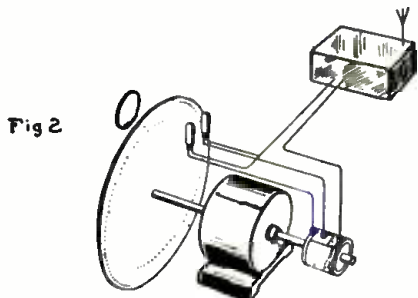

Fig. 2  
Receiving system for color television.

# Interesting Television Patents Reviewed

## Multi-Service Carrier

No. 1770205, issued to Alfred N. Goldsmith and Julius Weinberger, Assignors to the Radio Corporation of America. Patented July 8, 1930.

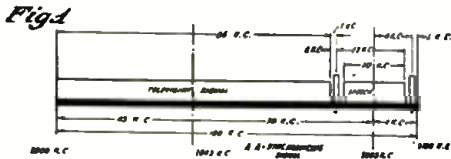

Fig. 1

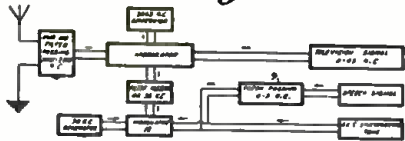

Fig. 2

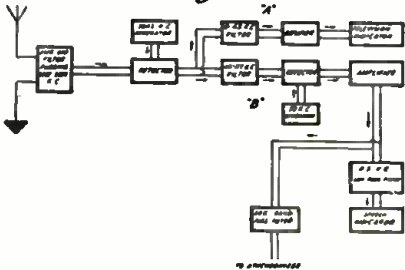

Fig. 3

Dr. A. N. Goldsmith and Julius Weinberger, both of the R. C. A. Technical Staff, have obtained this patent for operating a television system within the 100,000 cycle band.

A system for operating within the 100,000-cycle band permitted to television transmitters. A plurality of channels is so arranged as to transmit a television signal, a sound program and a synchronizing signal over a single carrier. The system employs apparatus similar to the carrier-current systems employed in telephone communication. Fig. 1 shows the manner in which the band is occupied; Fig. 2 shows the method of transmission and Fig. 3 the necessary receiving elements. A 2,043-kc. generator is modulated by a television signal of from zero to 43,000 cycles, and also by a 50,000-cycle carrier current, on which are superposed a speech signal of from zero to 5,000 and a

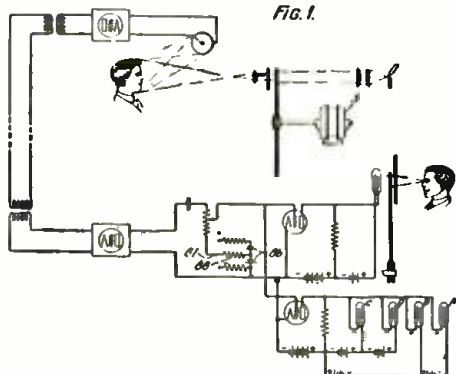

Fig. 1

This patent relates to a method for automatically adjusting the background of a received image.

6-kc. synchronizing tone. The manner in which these are separated, one from the other, by band-pass filters, is shown in Fig. 3.

## Background Adjustment

No. 1728122, issued to Joseph W. Horton, Assignor to the Bell Telephone Laboratories, Inc. Patented September 10th, 1929.

Method of automatically adjusting the background or initial illumination of a received image.

Heretofore the person viewing the received scene has had no knowledge of the basic brilliancy of the scanned scene. The only method he has had of obtaining the proper relationship, as to contrast, has been by previous knowledge or by adjustment of the current through the neon lamp for the best effect. In this invention a normal television transmitter, using the indirect method of scanning, is employed to feed a signal to a remote receiver. The final stage of this receiving amplifier contains manual means for adjusting the initial brilliancy of the image by virtue of a biasing and gain control in the grid circuit of the output amplifier. The initial bias on this tube is adjusted manually by means of the system 86, 87, 88. An optical effect, corresponding to an automatic volume control in an acoustic receiver, serves to adjust the background to the required intensity by means of multiple neon tubes operating at different striking voltages. Methods of obtaining the correct striking potentials for these tubes are shown in other figures not reproduced.

## Cathode-Ray Receiver

No. 1793406, issued to Ray D. Kell, Assignor to the General Electric Co. Patented February 17th, 1931.

A method of television reception with the cathode-ray tube.

The output of a low-frequency amplifier is fed to a cathode-ray tube in such a manner as to effect a variation in the intensity of the beam, in accordance with the signal output. This electron stream is passed through two pairs of electrostatic deflecting plates, across which the discharges of a pair of two-element tubes are connected. These two tubes are charged by means of a pair of commutators, operated in synchronism with the scanning disc at the transmitter. The charge is of the proper intensity and the discharge of the proper time-intensity characteristic, to shift the beam in accordance with the scanning at the transmitting point. One discharge device is so timed as to effect the horizontal scanning motion, and the other the vertical. The arrangement is such as to be used with a cathode-ray oscillograph tube of the type available for laboratory use.

## Staging Television

No. 1792259, issued to William A. Tolson, Assignor to the General Electric Co. Patented February 10th, 1931.

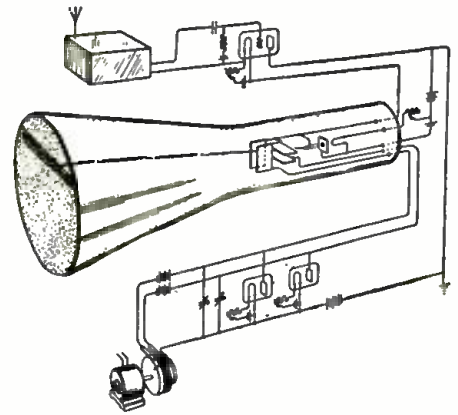

Television receiving circuit for cathode-ray tubes.

A system for transmitting an uninterrupted television program. Three scenes are set as illustrated below. Three separate scanning mechanisms are in motion, and in phase and synchronism one with the other; only one scanning device is scanning actively at any instant. Change of scene is effected without delay and without the necessity for resynchronizing at the received point, after the receiving scanner is once in step with the transmitter. Change-over may be made sharply by shutting off one light source or by a "fade out—fade in" arrangement. The purpose of the invention is the expediting of the television program from the standpoint of showmanship, rather than from the point of view of technical improvement or engineering advance. The invention is interesting because it is, in all probability, the first to be issued in this phase of the art.

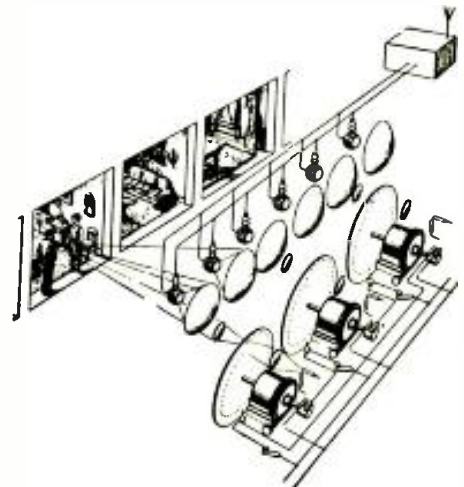

A method for staging several scenes in front of a "multiple" television pick-up, permitting the operator to switch from one scene to another in a smooth manner.

# SEEING IS BELIEVING

## W3XK Seen in Kansas

Editor TELEVISION NEWS:

You will probably be interested to know that we have successfully picked up the television image signal from W3XK, Jenkins studio, at Washington, D. C.

The signals were received by one of the usual short-wave sets available everywhere. Resistance-coupled amplifiers had been used in previous attempts to pick-up the Jenkins signals, but profiting from the experience gained in a recent television demonstration at the University of Kansas, the new amplifier was "impedance coupled."

C. BRADNER BROWN,  
Lawrence, Kansas.

*(Great work C. B. B. and we hope you will keep us posted on all the latest results you obtain in picking up Eastern television signals on your receiver in Kansas. This is pretty good work, and a large jump for television signals as none of the stations are using very much power just now and a strong television signal is necessary in any case. It therefore stands to reason that one can hardly hope to pick up a good television signal 1000 miles away with a television transmitter using possibly 500 watts or so. While it would not be considered much of a trick to tune in with an ordinary voice receiver on a broadcast station of average power at a distance of 1000 miles or more, we think it a fine piece of work in obtaining television signals at such a long distance. We hope to hear from more of our readers who have picked up television signals at a distance of 200 miles or more from the transmitting station.—Editor.)*

## He Photographed the Image!

Editor TELEVISION NEWS:

Herewith photo taken with my television scanner from images broadcast by the *Chicago Daily News*. My present television receiver is a ten tube set, using an 18" diameter scanning disc, driven by a synchronous motor with gear transmission.

In taking the photographs of the television image the first exposure I made was of 2½ seconds duration and other exposures were made up to 10 seconds duration. I have been experimenting with various television receiver systems for over two years, using spot and crater type glow tubes, with white or green light, which gives a better image than the ordinary, flat-plate, Neon tubes commonly employed.

With reference to the photos of the image I am sending please make note that these photos were taken while using my old disc and they show the lines quite strongly. My new

## We Can't Keep Our Hat On!

Editor TELEVISION NEWS:

I have just finished reading TELEVISION NEWS and am not disappointed with it. It certainly is the magazine that has been wanted for a long time. I find that it has very interesting and instructive material in it.

SIDNEY MAGID,  
275 Corbin Place,  
Brooklyn, N. Y.

*(Thanks Sidney, but if we get many more of these laudatory letters, we are afraid our heads will swell to such proportions that we will not be able to keep our hat on. We are making every effort to obtain the information which we believe the different classes of readers*

disc is free from lines, but I have not finished the pictures taken with it.

H. E. BURKET,  
819 Center St., Chicago, Ill.

*(Great stuff H. E. B. and we hope to hear from a great many more readers.)*



Mr. Burket's photo of image.

## From Carlstadt, N. J.

Editor TELEVISION NEWS:

For the past four years I have been a continual looker in on all television programs and have tried many amateur experiments in this new art.

A week or so ago I came in contact with a copy of TELEVISION NEWS and immediately subscribed to it.

The outfit contains a 60-line disc; short-wave tuner; 3-stage amplifier with 750 volts on the plate of the neon lamp.

The receiver is a Pilot Super-Wasp with regenerative control.

The amplifier includes a 224-227-210, and gives almost perfect pictures when operating correctly.

The disc is run by a fractional horse-power motor, with variable rheostat control.

I hope this will be of interest to you and any amateur who should like to get any information, I will kindly offer any help I can.

If you would it would be very kind of you to give me the address of Mr. C. H. W. Nason who writes for your magazine as I knew it before he left the Jenkins Television Corporation, but lost it since then.

Yours sincerely,  
EDMOND DEANE, JR.

*(Mighty glad to hear from you, Edmond, and we will endeavor to publish the article with diagrams and photos of your very fine television*

receiver in an early issue of TELEVISION NEWS. Address Mr. Nason care of this office. We hope every one of the enthusiasts who has a television receiver and scanner will dust off that camera they have up in the attic and take a picture of their "look-in" stations. Yes, "Visualists," we need every picture we can get to make this department real "newsy" and of real value to the other readers of TELEVISION NEWS. Don't forget, a nice clear picture and description of your set. We particularly are interested in knowing all about the stations you received and how much difficulty you may have experienced in holding the image steady; perhaps you have a new wrinkle or idea which you would like to pass on to your fellow television enthusiasts, explaining how to make a simple arrangement for framing the image and holding it steady. Thanks a lot Edmond, for your letter.—Editor.)

## From Batavia, New York

Editor TELEVISION NEWS:

Thought you would be interested in knowing that I have been obtaining good television images at Batavia, New York. I am using my own design of synchronous motor which has 120 poles. I have sent you a description of it for publication, if you elect to do so after reading the manuscript.

I drive the scanner disc shaft by belt with an ordinary universal motor, operated from a 110 volt A.C. lighting system. The speed of the scanner disc shaft is regulated to about 1200 R.P.M. and then my synchronous motor falls in step with the oscillator and holds the disc at this speed. My oscillator is linked up with the television receiver in such a way that during the reception the oscillator falls in step with the 1200 cycle component of the transmitted signal and in this way the automatic synchronization of the image is maintained.

KENNETH SHERMAN,  
Batavia, N. Y.

*(We are always glad to hear from any of our readers, especially with regard to articles describing some practical new application of some part of a television set. We have looked over the manuscript and undoubtedly we will have an opportunity to publish this in an early issue, probably the very next issue of TELEVISION NEWS. Don't forget, "Visualists," we pay for all articles accepted and published, at regular rates, and if you have any sort of home-made "gadget" which enables you to hold the television signal steady on your scanner, and give a better image than ordinarily obtained; remember, we are waiting for you with a check in our hand.—Editor.)*

## Letters from Readers

*of TELEVISION NEWS desire and we are endeavoring to publish at all times in the columns of TELEVISION NEWS the latest information available. Glad to have heard from you.—Editor.)*

## From An Expert

Editor TELEVISION NEWS:

The first issue of TELEVISION NEWS was called to my attention recently and it certainly is a mighty fine looking book. From the looks of the field, there is certainly room for a magazine dealing with the experimental end of television and the new developments, and I don't know of anyone better equipped than you to give out this information.

I certainly wish you all the luck in the world with your new magazine and hope that it will eclipse anything that you have yet published.

GEO. C. BAXTER ROWE,

Editorial Director,  
Electric Sound Institute,  
Easton, Pa.

*(Thanks George and we will probably need all of the luck you wish us, especially if this depression lasts much longer. However, we have a strong back and a hearty appetite for work, so we feel we have a winning chance to make TELEVISION NEWS the leading magazine in its field.—Editor.)*

*(Continued on page 318)*

# How to Make a Home Television Receiver With Synchronous Motor FOR DRIVING SCANNING DISC

Here is the data you have been looking for—how to build a synchronous motor of sufficient power to drive a television scanning disc for your receiver. The “tuner”, “amplifier” and “scanning disc” used with this motor by the authors, are also described in detail.

**T**ODAY we are entering the dawn of the age of television. What the future holds in stock is even more problematical than was the case with radio a decade ago. We have had many prophets, some more or less false; but on the whole much progress has already been made

By R. STAIR and  
S. R. WINTERS

aid. The research laboratories are doing their utmost, but help and public interest are needed. The amateur can aid, not only in research, but in

ply, radio receiver, and amplifier. Each of these may be constructed easily by following the description and illustrations.

## The Synchronous Motor — Mechanical Details

In Fig. 1, we have given a circuit-diagram and many of the details of construction of the synchronous motor. For the Jenkins system (now 1200) the disc rotates 900 times per minute (15 times per second) and is driven, at the transmitter, by a synchronous motor. Hence the problem of synchronism is solved by the use of a synchronous motor, built or geared to run exactly 900 revolutions per minute. This is accomplished directly, with elimination of noisy gearing, by building eight field poles (Nos. 1 to 8) for the A.C. windings. Logically, the rotor also should have eight poles in order to attain greater efficiency; but construction is greatly simplified by using only four poles as illustrated.

### Cores Built Up of Laminations

Each of the cores of the field coils and the rotor electro-magnets are built up of transformer steel, in laminations  $1\frac{1}{4}$  inches wide and piled to a thickness of 1 inch. The laminations for the rotor are each 5 inches long at one side, rounding to  $3\frac{3}{8}$  inches at the other. These are roughly cut to dimensions before assembly and then, after the rotor is complete, it is slowly revolved against a rapidly rotating emery wheel, until the ends of the four poles lie in a perfect circle. The field-coil poles, as illustrated for No. 4, are built of pieces of transformer steel, alternately  $2\frac{3}{8}$  and  $3\frac{3}{4}$  inches long. Connecting the poles are laminations of the shape WXYZ; dimensions WX =  $3\frac{1}{4}$  inches, and YZ =  $4\frac{1}{4}$  inches. Alternate pieces reach first to the center of pole No. 2, and then to the center of pole No. 3, etc.

After stacking the laminations for each field-coil pole, they are clamped in a vise, and a  $3/16$ -inch hole is bored about  $1/4$ -inch from the end. The pole is then slit (with a hack saw) from the end to the hole, as shown in Fig. 1. The pole is next given a curved

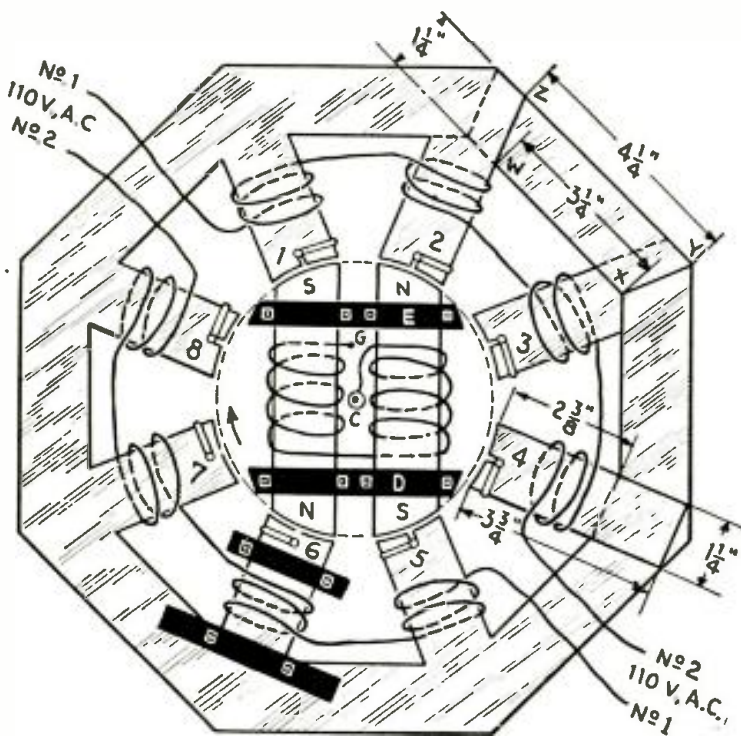

Fig. 1—At the left, shows construction and dimensions of the synchronous motor built by Mr. Stair and Mr. Winters, which has sufficient power to drive a scanning disc at constant speed for the reception of television images. Data are given for the magnet windings and the number of poles for both 48 and 60 line scanning. The motor is made from sheet iron or transformer steel laminations, tightly held together. The motor has shading coils on each pole tip. Terminals No. 1 are connected to one side of the A.C. line and the No. 2 terminals to the opposite side.

toward television, or radio movies, as a practical entertainment for the home.

The final receiver for the home will no doubt be as much different from the crude ones of today as the 1931 electric superheterodyne differs from the early crystal set. As with “talkies” in the case of the movies, sound and sight will again be combined to make radio entertainment complete.

### How the Amateur Can Aid Television

But are we to sit and wait for the perfect receiver? There is much work to be done—many improvements to be made—a new field to be explored. Again the call is to the amateur for

building up an interest as he has done with radio in many of its phases. It is with these ideas in mind that we are giving in this article the details of the construction of a relatively simple home television receiver.

The receiver described is of the motor-disc type and was designed for reception of the radio movies from Station W3XK. (48-hole disc, 15 revs. per second, Jenkins station, Washington, D. C.) Variations in the construction for use with stations transmitting 20 pictures per second are noted. (W3XK now 20 p. p. s.)

The complete receiver consists of a number of units; namely, synchronous motor, disc assembly, D.C. sup-

end, as illustrated, by holding its center to an emery wheel for a few seconds. One-half the pole is short-circuited by a single turn of very heavy copper wire (about No. 8 or 9) in order to produce a rotating field in the direction of the desired rotation of the armature. That is, the half of the pole in the direction of desired rotation is short-circuited.

**Winding the Motor Coils**

Each of the field coils consists of 400 turns of No. 24 D.C.C. copper wire, constructed on a removable form  $1\frac{3}{8}$  by  $1\frac{1}{8}$  inches and about 1 inch long; that is, the coils are made of a size to slip conveniently over the laminated poles. About  $2\frac{1}{2}$  pounds of wire were required to wind the eight coils.

The electro-magnet or armature windings consist of about 5,000 to 6,000 turns each, of No. 32 enameled copper wire wound on a form similar to the field coils, but about  $2\frac{1}{2}$  inches in length. All the windings are carefully protected by having a fiber or paper core, and are covered with shellac or rubber tape, to prevent mechanical injury from the outside.

The armature coils and laminations are mounted on a brass disc (iron must not be used) 5 inches in diameter and  $\frac{1}{4}$ -inch in thickness, with 8 bolts  $\frac{3}{16}$  by  $2\frac{1}{2}$  inches and the brass clamps D and E as shown in Fig. 1. (Again, iron must not be used for the clamps D and E.) The two sets of laminations are mounted about  $\frac{3}{4}$ -inch apart, located symmetrically with respect to the center of the brass disc. The brass disc was previously mounted on one end of the shaft of a reduction gearing, having a shaft 6 inches in length and a belt pulley on either end. The mounting was accomplished by soldering the brass disc to the smaller belt pulley (about 2 inches in diameter.) The windings of the two coils are connected in series, in such a manner that the adjacent poles are of opposite polarity, (test with compass needle or check direction of windings) when current is flowing through the coils. One end is grounded to the brass disc, while the other is connected to an insulated contact C, which is supported on a piece of

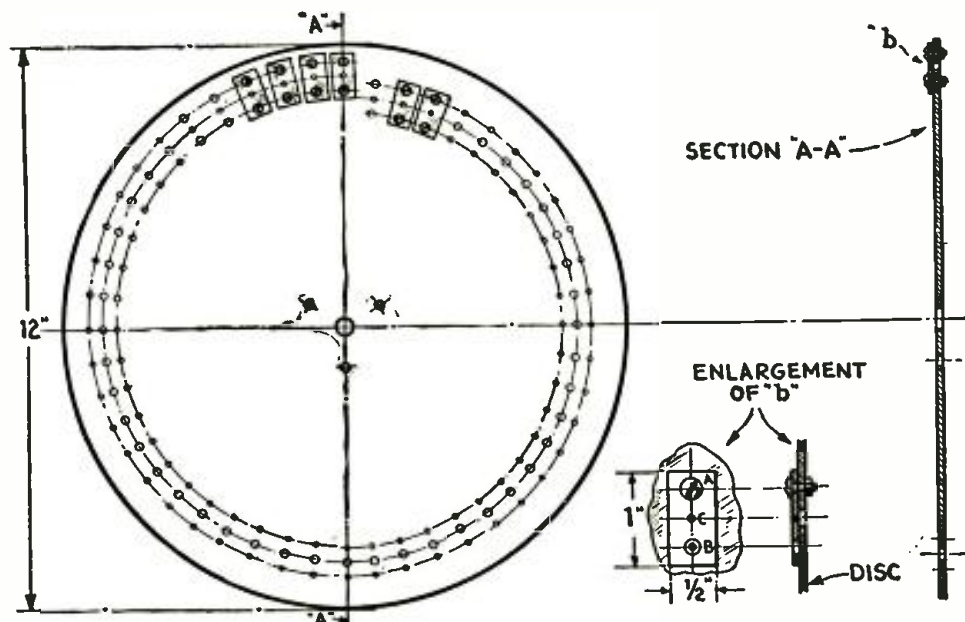

Fig. 3—Above shows details of the Stair-Winters scanning disc, which has movable plates, so that each "scanning hole" can be adjusted accurately.

bakelite between the clamps D and E. When the assembly of the armature is complete, and all the bolts made secure, it is now slowly rotated against the face of a rapidly-moving emery wheel as described above.

**Mounting the Field**

The field coils are mounted on the field poles and wired, as illustrated, in such a manner that alternate poles are of opposite polarity. It is an aid in assembly to prepare a full-size paper diagram similar to Fig. 1 and paste it onto the laminated mounting board. (If the board on which the field coils are mounted is not laminated, it is liable to warp or split. Bakelite, fiber, micarta, hard rubber, or other material may be used.) The laminations are held in place by clamps and bolts as illustrated for pole No. 6. They are adjusted tangent to a circle slightly larger than the armature; that is, a circle, previously drawn on the mounting diagram,  $5\frac{1}{8}$  inches in diameter. This gives a clearance of about  $\frac{1}{16}$ -inch between the field poles and the armature. The field coils are wired in series-parallel as illustrated; that is, the 110-volt A.C. house current is placed directly across the two sets of four coils in series.

The completed components of the motor are mounted on a wooden framework consisting of two 3 by 6 inch joists 18 inches in length, set on edge and separated by blocks 3 inches in thickness at the two ends.

One connection to the D.C. armature winding is made through the bearing, by connecting to the base of the shaft support. For the other a cone depression is made in the contact C with a metal drill and, by means of a spring, the pointed end of a large copper wire is held firmly in this cone as the armature rotates. Thus we get no arcing or sparking and, as a re-

sult, no electrical interference from the motor during the reception of pictures. Any motor using a commutator, such as the universal type, always produces more or less interference.

**The D. C. Source**

Since a source of direct current is required for this motor, and since only one set of storage batteries was available, we chose a heavy duty "B" power supply for energizing the D.C. windings. However, since one is interested only in obtaining a certain strength of poles, almost any type of D.C. source will serve, provided the windings are designed in the proper manner. If, for example, it is desired to use a six-volt storage battery, the windings may be made in parallel, and consist of about 300 turns of No. 24 D.C.C. copper wire on each core, in series, carrying 60 milliamperes. That is, our motor requires about 330 ampere-turns on each core for satisfactory operation. We have reduced the value of this as low as 250 ampere-turns in some of our tests, before the motor would fall out of step and come to a stop.

In Fig. 2 is given the circuit diagram of the "B" supply which we use. (Any good commercial "B" eliminator may be used.) The transformer is made on a core  $1\frac{1}{4}$  by  $1\frac{1}{4}$  inches cross section and having an inside opening, after assembly, about 2 by 3 inches. The primary winding consists of 600 turns of No. 18 D.C.C. wire; and there are three secondaries, each containing 600 turns of No. 24 D.C.C. copper wire, center-tapped. Each electrolytic rectifier cell consists of a central electrode of lead and two outer electrodes of aluminum, placed in a pint jar of saturated solution of borax, covered with a film of oil. A condenser (4 to 8 mf.) is necessary across the leads, as illustrated; since

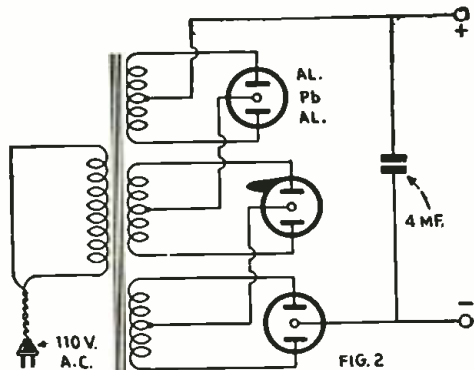

Fig. 2—Hook-up of rectifier used by the authors with their television receiver.

the armature windings have a high inductance and thus offer a very high reactance to unfiltered current direct from the rectifier.

The constructional details given above apply to a motor revolving 900 times per minute; that is scanning a picture 15 times per second. We believe that eventually most, or all, stations will change over to the 20-picture-per-second rate. Also many of our readers will desire to construct the motor for present day 20-picture broadcasts. In that case the design of the motor must be changed slightly as follows: instead of eight poles six are required. The armature will have to be constructed somewhat differently. One core piece, centrally located on the brass disc (which should be decreased in diameter to about 4 inches), is now required. If a "B" power supply is to be used, the winding should have about 10,000 turns of, say, No. 32 enamel-covered copper magnet wire. If a six-volt storage battery or a good "A" eliminator is available, the winding should contain 300 to 400 turns of No. 20 D.C.C. copper magnet wire.

The motor must be brought to synchronous speed by some means other than its own power. This may be accomplished either by belting it to another motor or to a high ratio (say, 10 to 1) pulley turned by hand. (We

trated in Fig. 3. The holes,\* 60 in number for the Jenkins (W3XK, Washington, D. C.) system at present, are located either by use of a template or by means of a compass and protractor. In either case large holes, about 1/8-inch diameter, are made at approximately the correct locations for the scanning openings. A pair of similar holes (one above and one below) are made 1/4 inch from the first set. Small plates of brass or copper, 1/2 by 1 inch, drilled in the center with a small hole (about 1/64-inch in diameter for a 12-inch scanning disc) are bolted to the disc with screws slightly smaller than the holes in them and in the disc. These are adjusted to the proper positions and securely tightened.

The radial adjustment can be checked conveniently by looking at any bright object (such as a frosted lamp) through the rotating disc. The lateral adjustments can best receive the final adjustment by checks against a broadcast figure. The holes out of adjustment are easily identified by temporarily plugging some of the openings.

The neon glow-lamp (we are using a 2-watt General Electric lamp at the present time) is mounted in the conventional manner back of the disc, except that a ground glass screen is

### The Television Receiver Circuit

The television receiver's circuit is illustrated in Fig. 4. It is more or less of the conventional tuned-radio-frequency, detector, and resistance-coupled amplifier type. Storage batteries are used for both the filament and the plate voltages. Tuning condensers, approximately .0002-mf., and coils about 2 inches in diameter, with 8 and 30 turns of wire, for the primary and secondary respectively, cover the range from 950 to 2,500 kilocycles. Caution is necessary, to prevent regeneration by sufficiently large grid resistors (about 1000 ohms), by-pass condensers, and proper shielding and placing of the radio-frequency coils. Broad tuning is essential for the proper reception of pictures.

The proper plate voltages depend in a measure upon the particular tubes used, especially the neon and the power tube. Some of our neon tubes require 50 to 100 volts more plate supply than others. As an example, we receive good pictures, with 200 volts plate supply and 22 1/2 volts "C"-bias, with one of our neon tubes in conjunction with a '71A power tube. We adjust the plate and grid voltages to give a continuous glow in the neon tube when no signal is being intercepted. The exact voltage adjustments are a matter of experi-

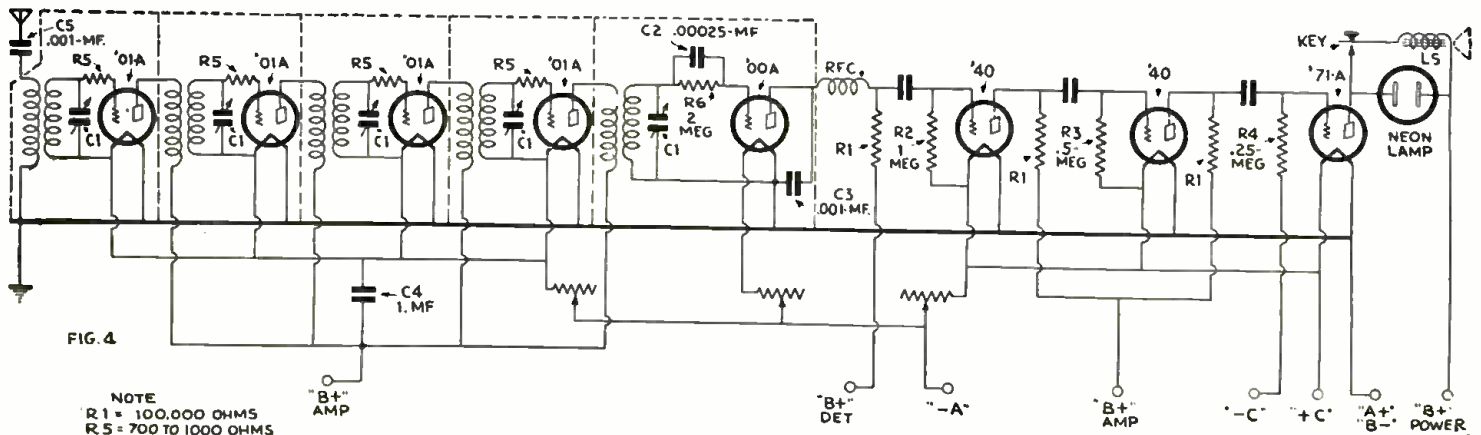

Fig. 4—Shows wiring diagrams of the Stair-Winters television tuner and amplifier, the latter utilizing three stages of resistance coupling. A key or switch cuts the loudspeaker out of circuit and the neon tube in circuit.

use an auxiliary induction motor.) If a meter is placed in either the A.C. or D.C. circuit, it will be observed to fluctuate when synchronous speed is being approached.

### Our Scanning Disc

The scanning disc is mounted on the end of the shaft opposite the armature; its special construction is illus-

placed between the lamp and the disc. This produces a more uniform field than the plate of the lamp itself, although at the loss of some light.

The ground glass screen is made by grinding a piece of ordinary window glass with "flour" carborundum. This is accomplished by placing the piece of glass flat on a blotter, covering its surface with carborundum flour and water, and gently rubbing by a rotary motion with a flat piece of steel until a uniformly ground surface is produced.

ment on the particular set-up employed.

Quite often, the picture is out of frame when it is first observed. There are eight possible positions for the picture to occupy when using the 8-pole motor described herein. With a little practice it is a simple matter to juggle the position of the picture by reversing the D.C. or A.C. leads by means of a reversing switch, or by opening and closing one of the circuits quickly. If the circuit is left open too long, the motor will stop.

\* For patterns of a 60-hole disc, see No. 2 issue of this journal. Also article in No. 3 issue, page 189.



# An Early TELEVISION and Picture Transmission Proposal

**T**HE following is a description of apparatus designed for transmitting views or pictures to a distance, jointly invented by the undersigned during the period elapsed between September 29th and October 11th, 1902.

At the transmitting station (A) there is provided a dark chamber (c) having a suitable lens (d) in an opening at the front. Inside the chamber, exposed to light rays entering through the lens is a ground glass plate (e).

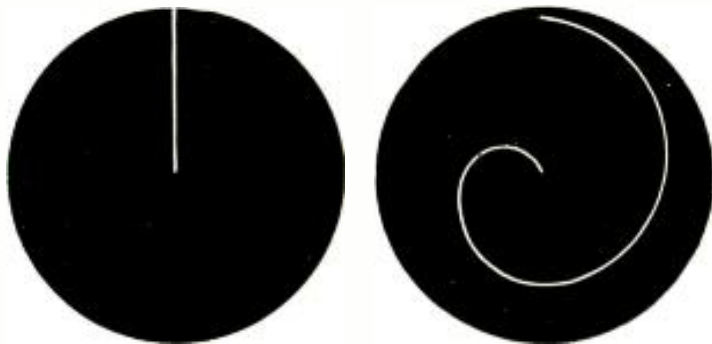

*Design of scanner disc proposed 29 yrs. ago by Mr. McQuarrie and Mr. Cook for television system which had many interesting and remarkable features.*

Immediately behind this plate is a contrivance with a pin-hole opening (f) arranged to be rapidly and continuously exposed to every point on the surface of the plate. Next in order is a lens (g) adapted to focus light rays passing through the pin-hole to the center of the chamber at the rear. At this focal point there is provided a substance such as selenium (h) which is susceptible to changes of electrical resistance under varying intensities of light. The selenium or other responsive substance is included in an electric circuit which extends to the distant receiving station (B) where it is joined to an electromagnet or other device (i) capable of responding to changes of E.M.F.

In the illustration an electromagnet is shown; the armature of which is fitted with a mirror.

A suitable dark chamber (k) is provided at (B); this chamber is equipped with a semi-opaque prism (m) at the rear. Inside the chamber is a ground glass plate (o) and in front of this plate is a device for exposing a pin-hole (p) to every point on the surface similar to that employed at the transmitting station.

In the operation of the apparatus a source of light (r) is provided at the receiving station so arranged that its rays are reflected to the prism at the rear of the chamber by means of the mirror attached to the armature of the electromagnet. In tracing the se-

**EDITOR'S NOTE:** The television and picture transmission scheme herein described is of special interest inasmuch as it was devised in 1902, 29 years ago, jointly by Mr. J. L. McQuarrie, then Assistant Chief Engineer of the Western Electric Company and now Chief Engineer of the International Telephone and Telegraph Corporation, and by Mr. W. W. Cook, then Chief Engineer of the International Western Electric Company, London, England. At that time photo-electric cells, Neon lamps and vacuum tube amplifiers were, of course, not available; nevertheless, the scheme embodies the fundamental ideas of practical television and picture transmission. The description is taken verbatim from the original manuscript signed by J. L. McQuarrie and W. W. Cook.

quence of mechanical movement of the armature of the magnet and the beam of light which is reflected from the mirror attached to the armature is caused to waver in harmony with this motion. The reflected beam will then sweep across the surface of the semi-opaque prism located in the opening at the rear of the receiving chamber. When the light beam is at the upper edge of the prism practically all the rays will pass into the chamber and its interior will be illuminated; when the beam is at the lower portion of the prism none of the rays can enter and the chamber will be dark. As the beam moves across the prism a gradual change from a condition of light to one of darkness occurs inside the chamber. It will thus be seen that if the pin-hole at the receiving station is caused to move over the surface of the ground glass plate located within the chamber the particular point at which the pin-hole may be situated at a given moment will appear to the observer to be either light or dark depending upon the condition inside the chamber. If then the pin-holes at both stations are operated with synchronism the view impressed on the ground plate glass at the transmitting station will be reproduced on the plate at the receiving station.

The pin-hole mechanism may consist of two discs placed one in front of the other and arranged to revolve at proper speed; one of the discs may have an opening or slot cut across its face from the center to the periphery the other disc may have a spiral slot extending out from the center as in sketch.

In place of the apparatus shown at the receiving station for deflecting the beam of light it is suggested that an electric arc be used and means be provided in the line for varying its intensity.

It is proposed that for the purpose of transmitting photographs or views of stationary objects a photographic plate be used at the receiving station and formed through the action of the mechanism.—*Courtesy of "Electrical Communication."*

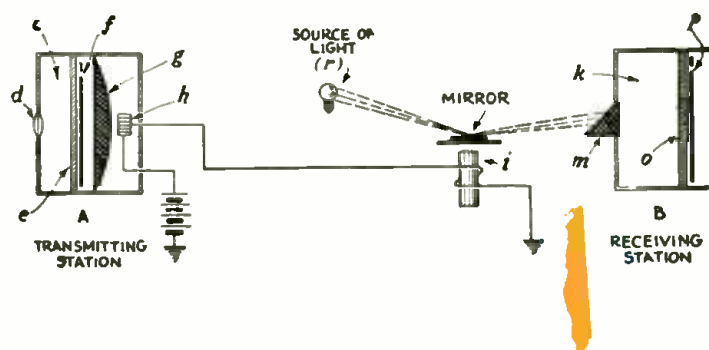

*Schematic diagram showing arrangement of transmitter and receiver in the McQuarrie-Cook television system here described. "f" scanner, "g" lens, "h" light-sensitive element; transmitter currents operate mirror; "p" '3auub3s*

# HOW SHALL I Synchronize Better?

By RUDOLF SCHADOW (Berlin)

**S**YNCHRONIZING means making the perforated disc of the television receiver revolve at exactly the same speed as the transmitting disc. Better synchronizing means accomplishing this with the least energy, and without encountering insuperable difficulties. Just how important is the last requirement, we may see from most amateur-made television sets, which operate without any special synchronizing apparatus.

This is one of the most interesting and valuable European contributions to Television the editors have found. Mr. Schadow discusses in plain language many unique methods of synchronizing or "keeping the image steady." Electro-magnetic brakes, relays, phonic wheels, etc., are all described.

right number of revolutions is obtained; on the contrary, the fluctuations in the number of revolutions of the motor have to be balanced.

### Electro-Magnetic Brake

Fig. 1 shows the plans of the electro-magnetic brake. The apparatus consists of the electromagnet E, the moving armature A, the brake shoe B, and the battery S. By the key T, provided with a long connection wire, the circuit can be closed from any desired distance. The braking takes place by spring pressure, which presses the armature and the brake shoe against the edge of the disc. At a pressure on the key, the braking is instantly stopped.

The opposite working arrangement, shown in Fig. 2, in which the braking action starts with the pressure on the key, does not make possible the fine adjustability of the braking pressure through the spring; so that under certain circumstances the brake acts too jerkily. Of course in the arrangement of Fig. 1, a key must be used which can be kept closed, or is provided with a lever switch; so that the disc can start unbraked.

### Where to Mount the Brake

Furthermore, in making such magnetic brakes many variations are of course possible. In order not to increase the already large dimensions of the television sets, it is well to put the brake in a corner of the housing, where the disc leaves a sufficiently large free space. Then the apparatus is so arranged that the brake shoe

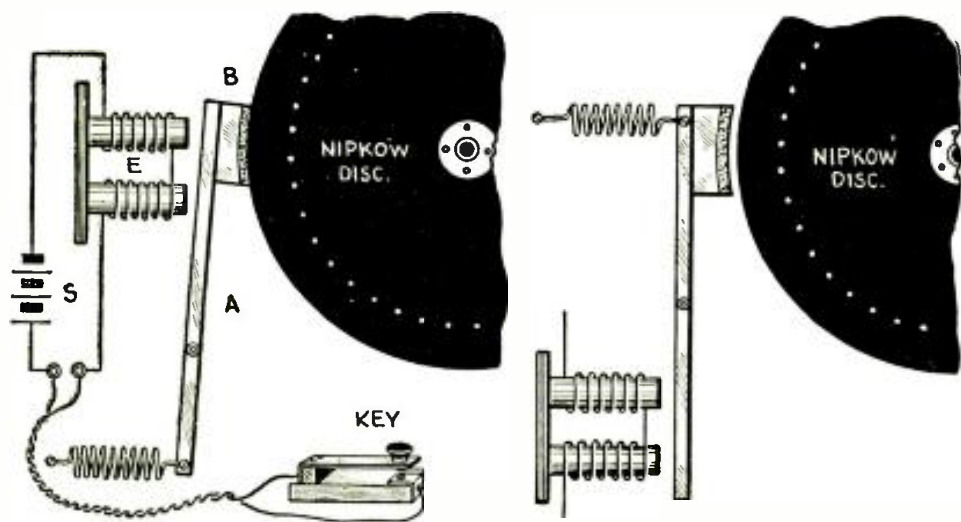

Fig. 1 (left).—Shows plan of electro-magnetic brake with hand-operated key.  
Fig. 2 (right, above).—Unfavorable braking arrangement.

The picture is simply, even if less conveniently, brought to a standstill by placing a finger against the circumference of the disc; thus bringing the somewhat fast-running Nipkow disc down to the synchronous number of revolutions.

It is much more elegant to accomplish this sort of synchronizing by braking of the disc. This method has an essential advantage over the very manifold proposals for regulating the number of revolutions, by changing the speed ratio between motor and disc-shaft; since one is not compelled to sit directly in front of the receiving set, but can choose any desired position which still affords observation of the televisior. Furthermore, a perfect synchronization can never be obtained, even by the most exact regulation of the speed ratio. If we operate the televisior with an ordinary motor, there is no question of so adjusting the motor to the disc-shaft that the

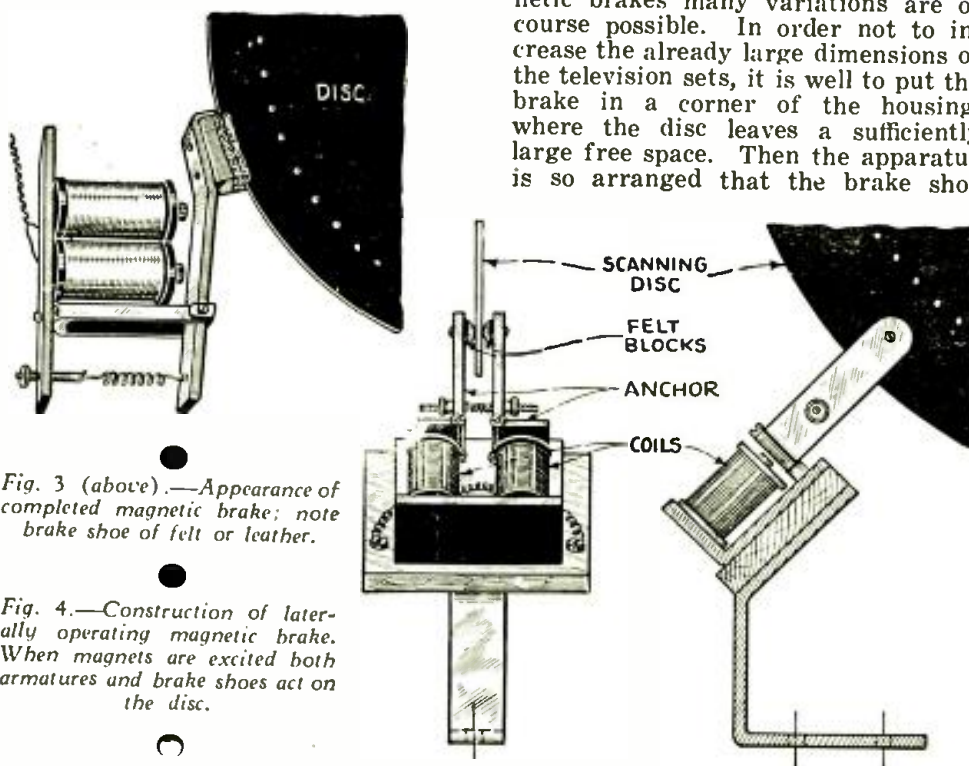

Fig. 3 (above).—Appearance of completed magnetic brake; note brake shoe of felt or leather.

Fig. 4.—Construction of laterally operating magnetic brake. When magnets are excited both armatures and brake shoes act on the disc.

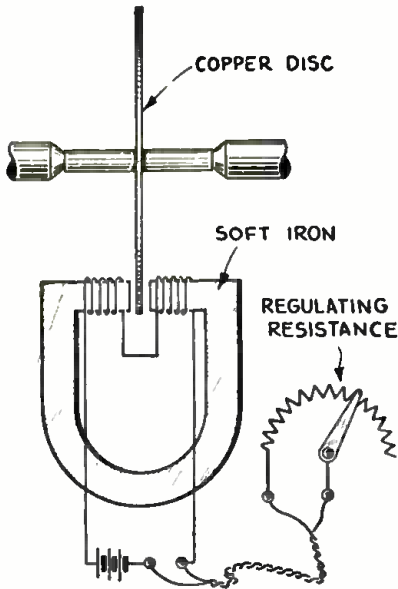
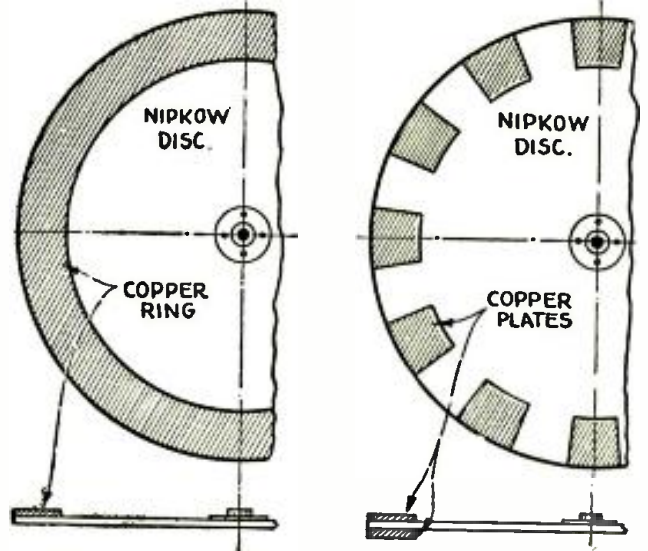

Fig. 5 (left). — Elementary principle of magnetic field braking, the copper disc being slowed down when rotating in a magnetic field.

Fig. 6 (right). — To utilize magnetic "drag" braking effect we would have to place a copper ring around the edge of the disc.

Fig. 7 (extreme right). — Copper plates or segments might also be used on disc.



stands at an angle of 45 degrees to the side where the attachment is made; as shown in Fig. 3.

Another arrangement, one working laterally, is shown in Fig. 4. Here two little blocks of felt press against the perforated disc, one from each side; this system is particularly recommended for timid persons, who fear a bending of the disc in the case of pressure on one side. In rapid rotation such bending is practically entirely impossible; on the other hand, with thin discs, this danger does exist, if the brake acting on the circumference of the disc is not switched off when turning the motor on or off.

As Fig. 4 shows, a corner-piece is provided for this brake also, permitting the placing of the apparatus at an angle of 45 degrees. One reader (Engineer Hans Teufert, Chemnitz-Reichenhain) casually made the suggestion of effecting the braking by the magnetic-field principle. With this scheme also, remote braking is possible, if we use instead of the key a regulating resistance provided with a long connection cord. The adjustment then takes place very gently and no pressure is exerted on the disc in braking.

**Copper Disc Brake**

Fig. 5 shows the plan of such a magnetic-field brake. The principle is that a revolving copper disc is slowed down in cutting a field composed of magnetic lines of force; the braking being stronger, the more powerful the magnetic field. From this it follows that with an arrangement like that in Fig. 5, we can exert a more or less strong braking effect on the disc, by simply changing the potential supplied to the magnet coils. To be sure, it is then necessary to make the disc out of thin sheet copper, or at least to provide it at the edge with a copper band. (See Fig. 6.) It is also possible to use the arrangement shown in Fig. 7, consisting of a number of copper plates distributed evenly on the edge of the disc. Finally, one can also put on the shaft of the scanning disc a special copper disc of smaller diameter (about 4 inches), an arrangement which seems to me about the most practical. I have not yet given such regulation, by magnetic-field braking, a practical, exhaustive test.

Most desirable, in any case, is a synchronization device which operates without any manual activity; *i. e.*, entirely automatic. For operating such devices any constant-frequency alternating current is suitable; it operates the various synchronizing apparatus, depending on the principle of the synchronizing wheel. One may either have the

alternating current produced independently of the transmitter and receiver, as, for example, taking it from the local house-current system; or produce it at the place of reception, by means of a tuning-fork interrupter; or finally (as the ideal way), use for this purpose the line-frequency of the pictorial (signal) alternating current. (See Fig. 8.) Certainly its use is not entirely simple; for on the one hand the synchronizing wheel requires relatively great initial power, and on the other hand the difficulties increase with the weight of the apparatus to be synchronized. Extremely precise work is therefore necessary, above all as regards the mounting of the disc. Furthermore, displacements of the center of gravity (unbalancing) of the disc must absolutely be avoided.

**Relay Synchronizing**

More suitable seems the relay synchronizing method which offers promising possibilities. So far as I know, it was first suggested by Baird; the operation of his system is shown in Fig. 9. It is not necessary to go into the details of this; for the principle can easily be explained by the arrangement reproduced in Fig. 10, to which long experiments have brought me. The operation depends on the fact that a special commutator short-circuits the pictorial-line alternating current (which is conducted not only to the glow lamp but also to a relay

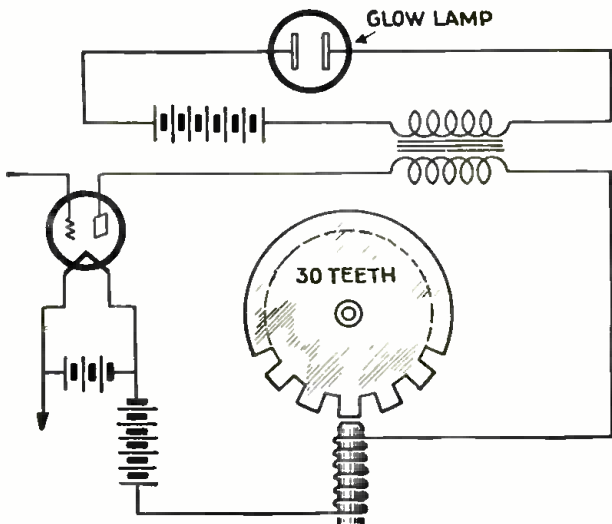

Fig. 8 (left). — Plan for synchronizing with "pictorial" A.C. by means of a phonic wheel.

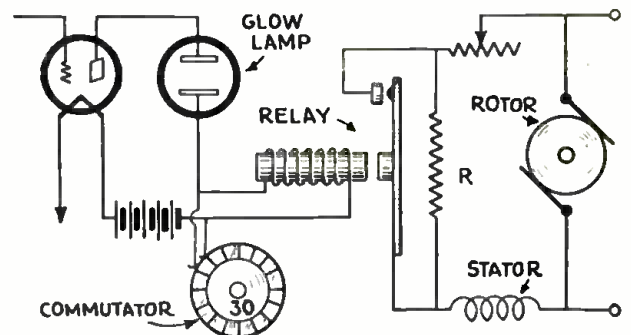

Fig. 9. — The Baird (English) method of "relay" synchronization.

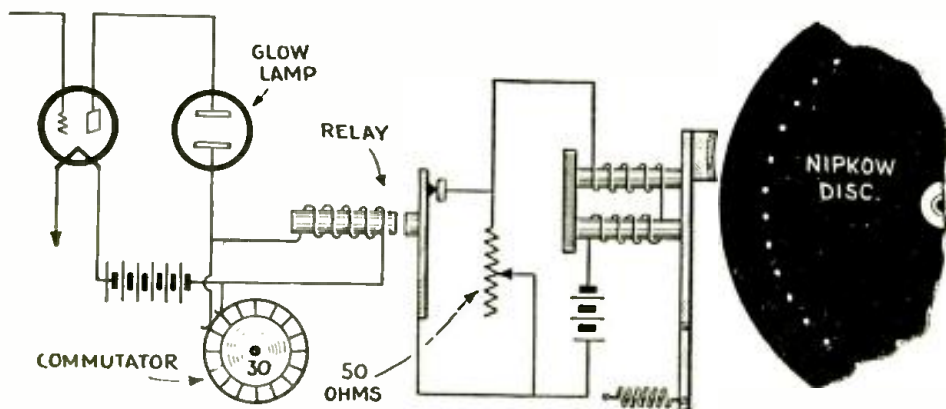

Fig. 10.—Relay synchronization with magnetic brake.

at the same time) at regular intervals, depending upon the number of revolutions of the scanning disc. At the proper speed of the disc, the relay gets only a slight current, which is practically zero; at a higher disc speed, however, it gets a stronger and stronger current and then begins to act. Thereby a brake is activated, which slows up the disc until its normal speed is again reached. The commutator wheel placed on the shaft of the disc must be connected according

tracted, and interrupts the braking-current circuit. Then the spring presses the brake block against the disc. It is obvious that in this way every other kind of braking action can also be performed.

In Fig. 9, for example, the braking is attained by short-circuiting a resistance, in series with the field winding of a shunt motor. This arrangement is based on the fact that a motor runs faster, if its magnetic field is weakened!

necessary amount. The parallel resistance is provided also for the previously-described arrangement; since it suppresses the formation of sparks at the relay contacts and excludes disturbances connected with them.

The relay can be dispensed with, if we build the braking device so sensitive that it can be directly activated by the relay current. Figs. 12 and 13 show corresponding arrangements, and Fig. 12 is in fact based on Fig. 10, and Fig. 13 on Fig. 11. Both hook-ups have as yet not been given a practical test; but I believe that through this simplification greater difficulties would arise in every case, due to the very precise work here requisite. Other than that, the system represented in Fig. 13, appears very interesting; because here the braking effect does not occur by jerks, but is controlled, within certain limits by the course of the disc at the time. Probably, however, the arrangement will also presuppose a higher initial power of the amplifier, whereby new complications arise.

**Synchronizing By A.C.**

That we can also use any other constant-frequency alternating current,

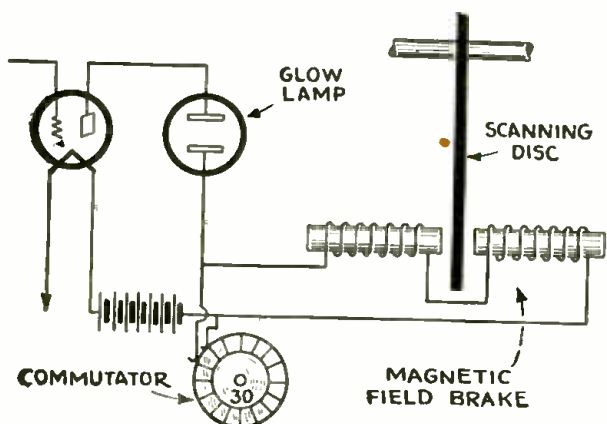
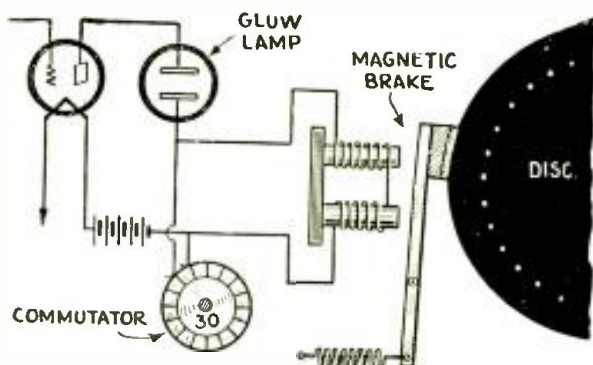

Fig. 11 (left).— Here we have synchronization by relay and magnetic field brake.

Fig. 12.—Electromagnetic synchronization with the brake connected in neon tube circuit.



to Fig. 10, parallel with the relay winding. Since the applications of the short-circuits are to coincide with the synchronizing line, the commutator wheel must have as many plates as there are pictorial lines used.

**How the Relay Works**

In Fig. 10 the above-described electromagnetic apparatus is used as a brake. If the relay receives a stronger current, through the faster running of the disc, the relay armature is at-

**“Shorting” Resistance**

Fig. 11, represents a relay hook-up which uses the principle of magnetic-field braking. Here there is in parallel with the relay contacts a regulating resistance, by which the braking power is so adjusted that the disc runs a trifle too fast. If the relay begins to act, the resistance is bridged; and the braking action is increased by exactly the

for the relay synchronizing, should be mentioned for the sake of completeness. Fig. 14 shows an arrangement which synchronizes the television by means of the 50-cycle alternating current supplied by a lighting circuit

(Continued on page 308)

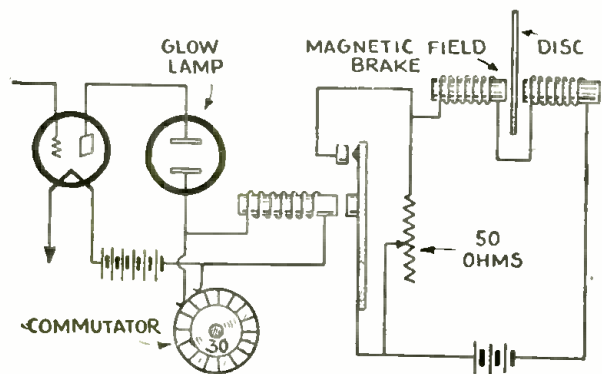
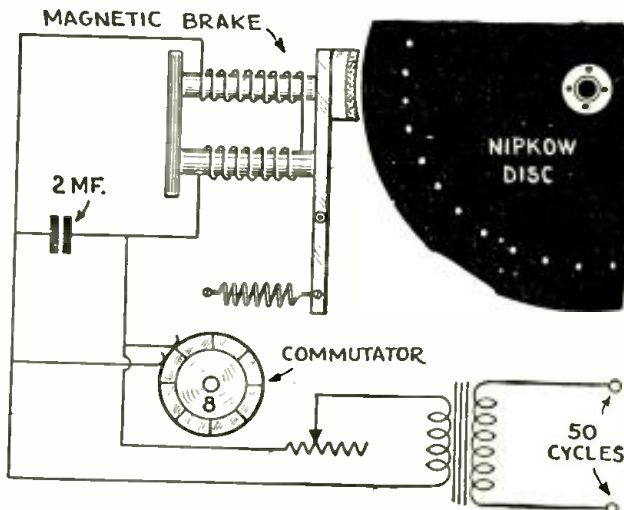

Fig. 13 (left).— Synchronizing by magnetic field brake without a special relay.

Fig. 14.—Synchronizing by phonic wheel or magnetic brake, operated from 60 cycle lighting circuit (50 cycles, German).



# A Receiver for TELEVISION EXPERIMENTS on Short Waves

By HANS GUNTHER

**I**N Europe there are as yet no regular television broadcasts on short waves. Yet the use of short waves for this purpose offers excellent prospects; because the necessary "breadth of band" becomes smaller, the shorter the wavelength. Therefore, by short waves, one can much more easily put a number of television broadcasts alongside of one another (and of radio programs) than today in the field of long waves, where one can transmit only radio programs or else television programs, not both.

For this reason experiments have been made in the United States on wavelengths below 100 meters, and it is surely only a question of time when we (Germany) will also change to these. The (British) Baird Television Co., is even said to be already constructing a short-wave television transmitter, which will certainly provide good reception in Germany as well. Naturally, this implies a properly designed receiver; therefore we have pleasure in describing a short-wave television receiver suggested by B. Marshall, which is a model of simplicity; so that our readers may be prepared in time for short-wave reception in this field.

Fig. 1 represents the hook-up of the receiver circuit. It contains, as may be seen, a regenerative detector, and before it a stage of radio-frequency amplification utilizing a screen-grid tube. After the detector follow two or three stages of audio-frequency amplification (not represented in our diagram), because there is nothing special to be said about this.

The new and surprising feature of the hook-up is the radio-frequency stage; for the view is usually set forth in the literature of the subject, that there is no sense in using screen-grid tubes below the 200-meter wavelength. A further surprising fact is that the hook-up provides no shielding of any sort. To be sure, Mr. Marshall advises putting the whole receiver in a metal box and thus shielding it entirely from the outside; but he expressly says that shielding between the individual stages is not necessary, which of course greatly lessens the difficulty of construction.

In spite of the lack of a tuned input, the receiver is said to be perfectly stable. This is attained, not only by giving up completely the tuning of the antenna, but still more by the avoidance of coils and the like in the antenna circuit. There is inserted in the antenna circuit a resistor R1, of about 100,000 ohms; the signal oscillations across this resistance are conducted to the grid and cathode of the screen-grid tube. It should be noted that this procedure is also ap-

Mr. Gunther sets forth some interesting considerations for the attention of all television and short-wave enthusiasts, with special regard to the arrangement of the receiving circuit for reception of wavelengths below 200 meters. This article deals particularly with the best form of circuit for the radio frequency and detector stages.

the output energy. The variable condenser C2, of only 100 mmf. capacity, serves in connection with coil L2 for regeneration. Condenser C1 is said to have a capacity of about 1 mf., and also condenser C7.

It is practical to make coil L1 exchangeable; this consists of a few turns of thick copper wire (there being no core) and is provided with a center tap. The number of turns and the diameter depend on the desired waveband to be covered. There have

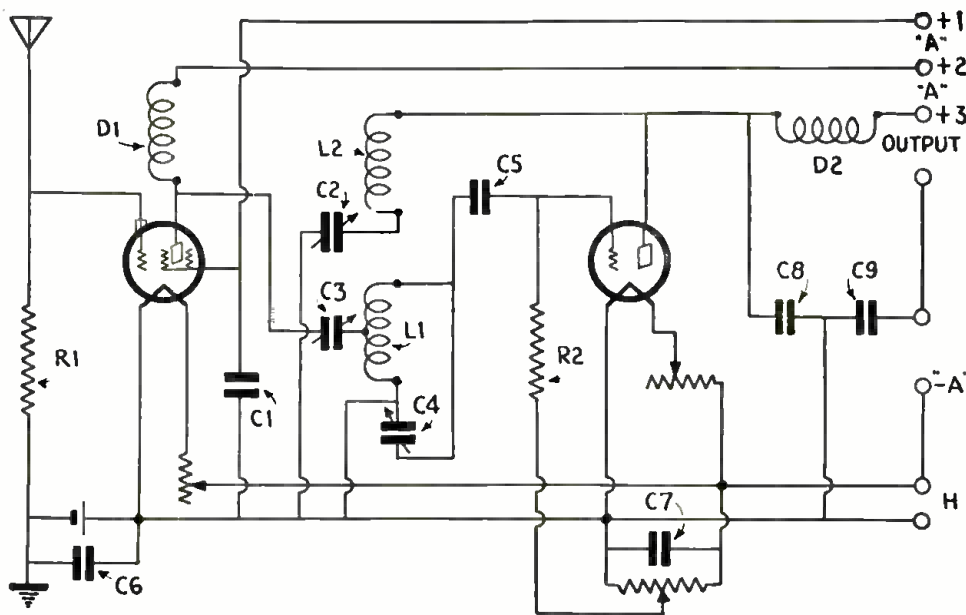

Fig. 1—Receiving circuit suggested by Mr. Gunther for good reception of the short waves used in television transmission, showing the use of a screen grid tube in the R.F. stage, and an ordinary three-electrode tube for the detector.

plicable on longer waves, but that it is then less successful.

The control grid of the screen-grid tube has a negative bias of 1.5 volts; the potential is furnished by a single dry cell, which is connected in parallel with condenser C6, which is of 1 mf. capacity.

The real tuning condenser is C4; it is to have at most 300 mmf. capacity. Condenser C3 serves for coupling the two tubes; one could also use for this a fixed condenser of 200 to 300 mmf.; but variable condenser of this maximum proves more practical, because with it one can most simply regulate

been so many statements about this in previous constructional articles that we do not need to go into the matter here.

Choke coil D1, which is to prevent the radio-frequency oscillations of the first stage from straying into the plate battery, instead of passing through the coupling to the second tube, is to be of the usual kind for high-frequency oscillations; *i. e.*, it must above all possess low self-capacity, so that the oscillations may not leak through the capacity of the choke. Suitable for this purpose are

(Continued on page 305)

# A New System of Synchronizing Used in The BARTHÉLÉMY SYSTEM

**A** FEW months ago, the French newspapers reported that there would soon be opened in Paris a studio in which would be given public demonstrations of a new television system invented by the French experimenter R. Barthélémy, well known in the field of radio and telemechanics.

A little later, the technical magazines began to give the first indications how this system differs from others; in the manner by which it obtains synchronism, and by the great exactness which it is possible to obtain in the synchronism between the transmitting station and the receiver. From these hints, the system appeared to be very new and interesting; especially since the predicted exactness is in the order of 1/10,000 of a second.

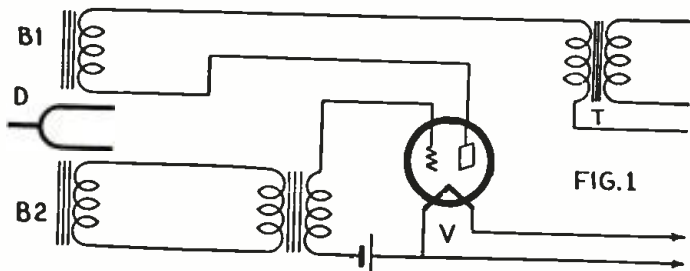

Fig. 1—At the left, shows vacuum tube—tuning fork arrangement used for the production of an alternating current of constant frequency.

Since an explanation, more or less complete, of the system in question has not yet been made, we give below all that it has been possible to learn, concerning the synchronization, rather than the remainder of the apparatus.

The basic patent, on "Motors for relays, and their applications," applied for in France by Barthélémy on February 25, 1929, and granted July 11, 1930 (No. 685,512) deals with motors for receiving apparatus; the principal part of the invention being concerned with a new type of direct-current motor, without brushes, by the revolution of which the transmitting apparatus is controlled.

### The Tuning Fork-Driven Oscillator

To understand properly the workings of this motor, let us first study the operation of a vacuum tube-tuning fork—an arrangement frequently used for the production of alternating current of constant frequency. In the diagram (Fig. 1) the tuning fork D is placed between the two coils B1 and B2 which are inserted, respectively, in the plate and the grid circuits of a vacuum-tube V. In the plate circuit of the latter is located also the primary of a transformer, from the secondary of which the desired alternat-

**A new and simple means of establishing synchronism between the television transmitter and receiver is here described, the system using a special synchronizing impulse sent from the transmitter once for every revolution of the scanning disc.**

ing current is to be drawn for its application. When the filament of the tube is lighted, and the proper voltages are applied to the plate and the grid, the plate current flows in B1; but without causing any oscillatory phenomena while the current is constant. On striking the tuning fork D, however, the magnetic field of B1 is

varied by the mechanical motion of the arms of the fork (which serve as armatures); and not alone that of B1, but also of B2, by which means there is generated a current which, when applied to the grid, is amplified in the plate circuit and therefore in B1. This variation of the current is opposite in phase to the preceding one, which was given by the first stroke on the fork; the arms of the fork are attracted in the opposite direction; and the fork will be thus magnetically excited. The excitation will be renewed with the vibration of the fork; the phenomenon will become periodic; and a flow of current in the plate circuit will be maintained by the plate battery of the tube and will take the frequency which corresponds to the fundamental of the tuning fork.

### The Use of the "Phonic Wheel"

Substituting a "phonic wheel" for the tuning fork, and giving it an initial impulse, it will continue in revolution at a speed increasing continually until it reaches the limit which is determined by the losses, and the shape of the "characteristic" of the tube. In this arrangement is found the essential novelty of the Barthélémy patent, in which it is stated that "the movement of the wheel is

governed by the grid of the tube, making a motor very easily controlled; and also the elimination of the brushes and the ability to use very light and mobile apparatus permits a considerable reduction in the power needed to obtain the required velocity for television scanning discs."

Analyzing the manner in which this "D.C. motor without brushes" is applied by Barthélémy to the synchronization of the receiver with the transmitter, we will consider Fig. 2; in which B1 and B2 are coils like those used with the tuning fork in Fig. 1. When the phonic wheel A is set in motion, the plate and grid circuits of the tube will become the path of an alternating current, the frequency of which depends on the number of poles and the speed of revolution of the wheel; while the driving force will be determined by the voltages on the plate and the grid, and may be exactly proportioned to the plate current by a proper adjustment of the electromagnet B1.

Putting the wheel in motion, let us apply to the grid circuit, by means of the transformer Tg, periodical voltage impulses which are furnished, for example, by the television transmitter. It is evident that, if these impulses have the same frequency and are in phase with those of the grid voltage, the functioning of the system will not be changed, nor the speed of the wheel.

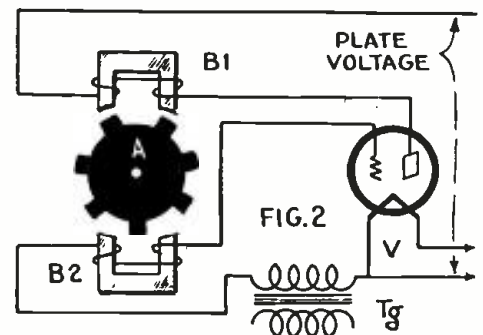

Fig. 2—Phonic wheel tube system, the control impulses being impressed upon the tube grid circuit through the transformer Tg.

But, if its speed is such that the voltage variations set up in the grid circuit by the revolution of the wheel have a frequency differing from that which is applied to the transformer Tg, there will be set up in the plate circuit impulses which will either aid or oppose the motion of the wheel, and will therefore tend to increase or to diminish the frequency created by its revolution. Under these conditions,

the wheel will be compelled to revolve at a speed at which these impulses in the plate circuit of the tube are cancelled out; *i. e.*, at such a speed that the oscillations in the plate circuit of the same frequency as those impressed upon the transformer, and in phase with them. That is to say, the wheel will be governed by the frequency of the current applied to Tg.

In order to apply a similar arrangement to synchronizing television apparatus, it is necessary that the transmitter shall send out a frequency equal to that generated by the motor. To avoid the necessity of another circuit, or channel, from that used for the image-frequency, Barthélémy has invented an ingenious arrangement by means of which, utilizing the principle described above, it is possible to obtain practically perfect phase-synchronism between the revolving parts of the transmitter and the receiver.

**One Signal at Each Revolution**

For this purpose he sends, at each turn of the scanning disc of the transmitter, a current impulse of greater amplitude than that obtained by scanning the single elements of the image; since, between the end of the scanning by the last hole of the disc, and the beginning of the repetition of scanning by the first hole, there is a little interval which is utilized for the sending of the synchronizing impulse. This is sent out at every revolution, instead of a frequency based on the scanning (30 cycles for every turn of the wheel, characteristic of the Baird system; or six cycles to each turn, as in the Mihaly system).

Since Barthélémy gives this synchronizing impulse a duration of only 1/10000 of a second—and for many reasons the time cannot be longer—it is necessary to have some special circuit to utilize such a brief impulse for synchronizing; for the signal itself could have no overpowering influence over the much longer period during which current is generated in the tube circuit by the revolution of the motor.

On the other hand, the synchronizing impulse is sent out at each revolution of the motor—that is, 16 times a second (the speed adopted by Barthélémy in place of the 12.5 turns a second used by Baird); making it necessary that the motor of the receiver shall also turn at the rate of 16 times a second and that the frequency of the current generated in the tube circuit shall be 16 cycles, in order that control of the motor may be obtained by these synchronizing signals.

These considerations resulted in the adoption of a phonic wheel with only two teeth; or rather, of a bi-polar motor, since a wheel of this kind could not function. His purpose is accomplished by Barthélémy with the arrangement shown schematically in Fig. 3, as followed in an experimental receiver which has been constructed. To the input of the transformer T1

a synchronizing impulse is applied for 1/10,000 of a second; this impulse having, while it lasts, a much greater amplitude than the image-frequency signals. This is sufficient to create in the secondary a voltage high enough to cause the lighting of the neon lamp V (which is separate and distinct from that by which the image is scanned), producing a condition very close to, but distinctly different from that required for the generation of continuous oscillations. This is regulated by the selection of the proper constants for all parts of the circuit.

**The Local Oscillating Circuit**

The lighting of lamp V, by the striking voltage created by the signal,

(lasting for 1/16-second) which is generated by the charging of the condenser C until the arrival of another synchronizing impulse; then whatever difference in phase may have taken place, across the motor in the local circuit is corrected by the impulse which forces the motor back into the proper phase. The exactness of synchronism obtainable in this manner might vary slightly, with possible voltage variations in the system supplying current to the whole circuit.

**Use of Six-Inch Disc**

As to the remainder of the television receiver invented by Barthélémy, he uses a scanning disc of the Nipkow type only 6 inches in diam-

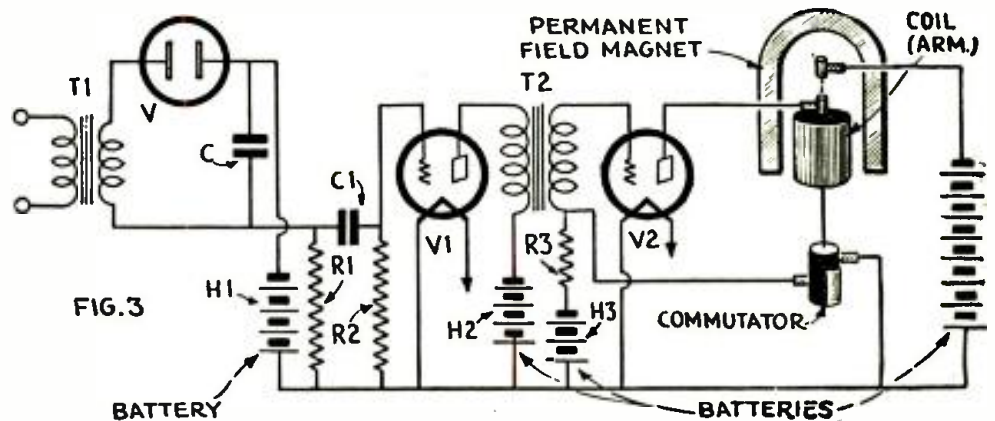

Fig. 3—Above shows circuit finally adopted by Barthélémy, for controlling the speed of motor accurately at the television receiver. V, represents a neon tube which periodically charges and discharges the condenser "C," which is charged by the battery H1.

permits the discharge of the condenser C (through the ionized gas); the condenser, after the lamp has gone out, is again charged by the battery H1, which prepares it to receive another signal. The discharge of C causes, by reason of the voltage drop across the coupling resistor R1, an oscillation to be generated in the circuit R1-C1-R2; the phase of the oscillation is determined at the instant of the end of the signal, though its amplitude is governed solely by the constants of the circuit. With proper values for the capacity C and the resistance R1, the period of this oscillation may be fixed at 1/16-second; that is to say, exactly equal to the interval between signals and to the frequency of the motor.

The oscillating voltage, applied across the resistor R2, is then amplified by the tube V1 and fed into the grid circuit of V2, in the plate circuit of which is inserted the bipolar armature of a magneto. To obtain with a motor of this type the corresponding voltage variations in the grid circuit of V2, it is necessary to employ a commutator which, together with the "C" battery H3, puts the proper bias on the grid of the tube at each revolution.

By the arrangement which has been described, the motor is compelled to remain in phase with the local oscilla-

eter, in order to reduce the inertia of the moving parts and to avoid the necessity for an expensive high-power tube; since the whole of the power for the motor is drawn from the last tube V2.

Because of the very small size of this disc, a neon (or helium) lamp with a very small, but brilliantly-lighted plate is used; and the image is highly magnified by an optical system. The disc revolves in a horizontal plane.

It is stated that, with the system shown, practical results have been obtained noteworthy for the definition and the absence of drift in the images, though, it seems, without other advantages over what has been accomplished with other systems. After brief public exhibitions, it will be possible to draw definite conclusion as to its efficiency, and the real advantage of this new method of synchronization.—*La Radio per Tutti (Milan).*

**Barthélémy System Demonstrated**

The demonstration of television which M. Barthélémy gave recently at the École Supérieure d'Électricité, at Malakoff, aroused a curiosity which exceeded all expectations. The amphitheatre was filled before the appointed hour, and it was necessary to give a second showing to satisfy the hun-

(Continued on page 315)

# The TELEVISION QUESTION BOX

## Regeneration vs. Television

G. W. Anderson, Lexington, Va.

Q. 1. In a recent article on the construction of a television receiver, Mr. Nason says that regeneration does not necessarily destroy the quality of reception. All other information on television states that regeneration cannot be employed, if the details of the image are to be clearly received. Can you explain this

out the television band and an intermediate frequency amplifier which fed directly into the neon tube. Naturally the final "I.F." amplifier tube would have to be capable of a rather large out-

Edited by  
C. H. W. NASON

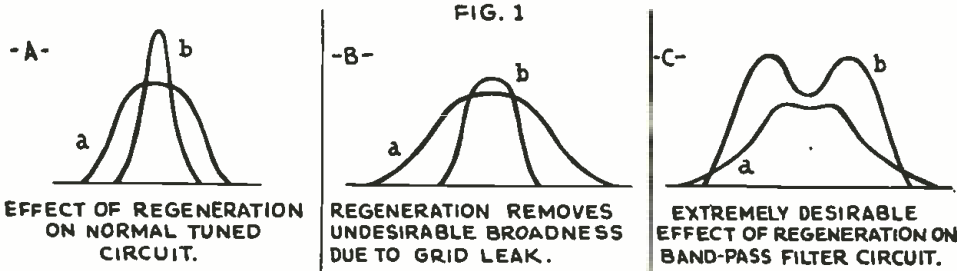

Various effects of regeneration in tuned circuits graphically portrayed.

point more clearly for me; since my receiver will not pick up the television stations with good signal strength, unless I use regeneration?

A. 1. It is quite true that regeneration affects the quality of the television signal in the ordinary receiver. When used in circuits employing band selectors, regeneration is a distinct aid to reception of the television signal. When used in connection with a grid-leak detector, as in the receiver in question, the regeneration has no effect on the quality of the signal as determined by the tuning elements. Its sole purpose is to compensate for the presence of the grid leak in parallel with the tuned circuit. The three figures here reproduced show the effect of the regeneration in each of three cases described in the captions.

## Neon Tube Inquiry

Arnold Jones, 342 State St., Portland, Maine.

Q. 1. Can the ordinary type of neon tube be used with radio-frequency energy directly on its elements? Are there any special precautions to be observed when the tube is operated in this manner?

A. 1. To the writer's knowledge, the usual type of neon glow lamp will operate at frequencies of the order of several hundred kc.; whether it will operate as well in the short-wave or television band, he cannot say from experience. Inasmuch as the major proportion of the distortion, present in television receivers, is due to the detector or low-frequency amplifier circuits, it seems self-evident that the best form of television receiver would be one in which the detector and subsequent amplifier stages were entirely done away with. It would be a simple matter to build a superheterodyne receiver, having an input tunable through-

put. Offhand, it would seem that a receiver employing a single '24 as detector and a '27 oscillator, feeding into an intermediate-frequency amplifier, consisting of two or three '24's, followed by a pentode or a '10 would prove suitable.

A system for efficiently matching the impedance of the '10 to that of the neon tube could be devised, so that the overall efficiency of the system would be far superior to that of the ordinary tube. It would still be necessary to provide a D.C. bias for the neon tube, so that the average value of the picture background could be adjusted at will. It would be impossible to use this receiver for the reception of sound, except with a particularly fine "condenser" speaker. A switching arrangement could, however, be devised so that the final R.F. amplifier could be biased at will as a detector; operating as a detector feeding a small loudspeaker, when so desired for the reception of sound. The writer has been working with such a receiver for some time past, but has never had it in sufficiently good form for publication, because of his desire to get the utmost out of it before passing on the information.

So long as the tube is sufficiently rapid in operation to follow the carrier frequency, its average illumination will vary in accordance with the modulation impressed upon the carrier at the transmitter. It is the writer's opinion that, if our neon tubes were more scientifically designed, they would operate even in the television band; so that no such expedient as the "super" would be necessary. It is a perfectly simple matter to design intermediate-frequency transformers having a band width such as is required in television service. Those already on the market could doubtless be made to do so by simply changing the coupling between the windings.

## Wave Trap for Television

Herbert LeRoy Chase, Quincy, Mass.

Q. 1. I have a television receiver and scanner, as sold by the Short Wave and Television Laboratories. I receive the television programs both from Boston and from two New York stations with excellent results. I have considerable interference from local broadcasters; which I am told is due to my receiving the second harmonic of their output on my television receiver. I called up one station and they told me that they were working well within the limits specified by the Federal regulations. Will a wave-trap help me in cutting out this interference? If so, should it tune to the harmonic of the broadcast station, or to its actual wave?

A. 1. No receiver—whether for broadcasts, short waves, television or what not—can be operated successfully with the so-called "untuned antenna" or "buffer" stage. This is particularly true in the case of the screen grid tube. Certain manufacturers of radio equipment were early to recognize this fact, while others seem never to have grasped the situation. It is possible that, if the broadcaster interfering is on a frequency just one-half that of the television transmitter, the second harmonic is troubling you; this would have a frequency just double that of the fundamental. For a short time W2XCR experienced this trouble when operating on a frequency just twice that of WAAM. In all probability your trouble is due to "cross talk"; this is due to actual modulation of the signal occurring in the plate circuit of the first tube, when the fundamental of the broadcaster is sufficiently strong to overload the grid of the first tube.

A wave-trap as shown in the accompanying sketch would admirably serve to reduce this type of interference. The specified coil and condenser are standard as made by Hammarlund. Modern practice precludes the possibility of a large harmonic output from the transmitter, and it is doubtful whether your interference could be so caused.

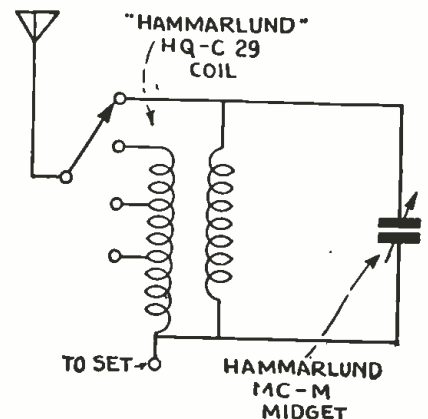

Wave trap circuit for television receiver.



**A Receiver for Television Experiments on S-W's**

By HANS GUNTHER

(Continued from page 301)

one-layer cylindrical coils wound on tubes of hard paper (fiber) or hard rubber of 2-3 cm. (1 to 1.2 inches) diameter, with 100 to 300 turns, according to the waveband desired.

The grid condenser C5 of the detector tube is to have about 100 mmf. capacity. The grid resistance R2 is to be somewhat greater than usual; about 5 megohms.

In the plate circuit of the detector tube are likewise two more condensers; of which C8 serves to keep the radio-frequency current out of the audio-frequency amplifier, so that only the rectified portions are amplified. For this purpose the condenser has a capacity of 100 mmf. while condenser C9 may be 1000 mmf. (.001 m.f.). The same rule applies to choke coil D2 as to D1. Note, finally, that the grid resistance R2 leads, not directly to the cathode of the detector tube but to a potentiometer, which is bridged by condenser C7, as stated before.

The operation of the receiver is very smooth, because the adjustment is very simple. First the potentiometer is set at about its mean (middle) value; after which one experimentally turns the regeneration condenser. If a point is found at which the self-excitation sets in, then the potentiometer is turned to one side or the other (generally to the positive side) until the tube no longer oscillates. After that the coupling condenser C3 is set to its maximum value, and the tuning condenser C4 and the regeneration condenser are varied in the usual way.—Rafa, 1931, H-3.

**Behind Closed Doors in a Modern Television Lab.**

By CLYDE J. FITCH

(Continued from page 289)

the neon type has some advantages; in that the former is sluggish in action and the lamp emits light after it has once received an electric impulse from the scanner, and therefore there is virtually no flicker to the images. In the process described by Mr. Heller, there is no limit within reason to the number of lamps that could be used, but the number required to reproduce a standard 60 line image would be 4320.

Where this lamp system has been used before, some form of commutator which connects one lamp after the other to the output circuit of the television receiver was employed.

"We have a new type of commutator, which has no electrical or mechanical contacts," Mr. Heller said.

**\$19.75 TELEVISION \$19.75**

Everybody can now afford the

**SEE ALL TELEVISOR KIT**

A complete outfit at less than the cost of a synchronous motor. Easily assembled in less than 30 minutes. Get in on the ground floor of this amazing new industry. Be among the first to see as well as hear your radio entertainment.

**ANYBODY** can assemble the **SEE ALL Televisor**

**YOU GET ALL OF THIS FOR \$19.75**

**Complete eddy current motor . . . 60 line square hole double spiral scanning disc made of special alloy aluminum . . . Rheostat . . . Condenser . . . Adjustable lamp housing and bracket . . . Synchronizing wheel . . . All necessary wiring . . . Complete blue prints of televisor . . . Complete blue prints of short wave receiver . . . Detailed assembling instructions.**

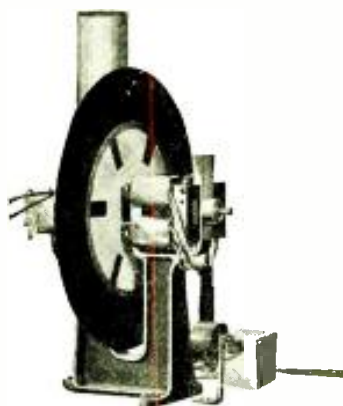

The SEE ALL Televisor is the lowest priced quality kit ever produced. It is unconditionally guaranteed against mechanical or electrical defects.



**TELEVISION PRODUCTS CO. OF AMERICA**

5 Union Square, New York

**JOBBERs and DEALERs—Wire or Write for franchise**

Any of these parts can be purchased separately. Write for Price List.

Price of **SCANNING DISC** only — **\$2.50**

TELEVISION PRODUCTS CO., of AMERICA  
5 Union Square, New York  
Send me the **SEE ALL TELEVISOR KIT C.O.D.** I will pay postman \$19.75 plus forwarding charges.  
NOTE—If remittance accompanies order, forwarding charges will be prepaid.

Name.....  
Street.....  
City..... State.....

# RESISTORS *for* The TELEVISION RECEIVER

## Line Ballasts

By H. G. CISIN, M.E.

**T**HE importance of the line ballast to the radio receiver has long been known. In the television receiver it is even more important. For ordinary sound reception, a fluctuating line voltage is not as immediately obvious to the listener, and shows its destructive effects later in short tube life and consequent costly set operation. While tone quality may be impaired under subnormal voltage operation, it is often overlooked or partially corrected by the tone control.

In the television receiver, fluctuating line voltage causes immediate erratic reception. The images become less clear or fade away entirely; and the set must be "forced" to bring them back. Such effects are very apparent and annoying, but they can be avoided easily by the proper use of a line ballast.

The clarostat line ballast illustrated is a special type of resistor whose resistance varies with temperature. In other words, as the line voltage rises, the current through the resistor increases, causing the temperature of the unit to rise and increase its resistance. This automatically prevents the line current from increasing greatly, and maintains a relatively constant input voltage to the set.

These line ballasts are made for currents between 0.3 and 1.75 amperes. In selecting one, it is important to know the amount of current that the set draws. This depends upon the number of tubes and other factors and is best determined by actual measurement with an ammeter.

For best voltage regulation, the power transformer should be wound for 85 volts or be provided with an 85-volt tap on the primary, as shown in the diagram. The line ballast is shown at 1. When so used, the line voltage may vary between 95 and 135 and the input voltage to the set will remain practically constant—or within the limits allowed by the tube manufacturers. Of course the ballast must be properly matched to the power transformer to obtain these desirable conditions.



Above: The automatic line ballast is indispensable for television sets.



Left: Standard clarostat, useful for regulating neon tube current.



Right: Clarostat flexible wire resistors are used widely in S.W. and television receivers.



Graphite element volume control with switch, recommended for use at 8, in diagram below.

## Television Motor Speed Control

All television enthusiasts are not fortunate enough to be located within the district supplied by the same electric power that feeds the transmitter, and thus to be able to make use of a

simple synchronous motor for operating the televisior. Even if they were located within the vicinity of the transmitter, there are other stations which they would like to receive which operate on some other power supply system. Therefore, the most universal televisior employs a main driving motor of the ordinary induction, universal or D.C. type, in conjunction with a synchronous phonic motor regulated by the image signal frequency. Accurate speed control of the main driving motor is essential. If it has a tendency to vary widely the phonic motor will not have sufficient power to "lock" the speed in synchronism and the image will disappear.

To supply the demand for a reliable and easily operated speed control unit, clarostat engineers have perfected a special variable resistance motor control unit. This unit has a resistance range of 25 to 500 ohms and is rated at 80 watts. It is shown in the diagram of Fig. 1 at 2. A short-circuiting push button switch is attached. This is very convenient in television reception for quickly accelerating the motor speed, by pushing the button. By this means, synchronous speed is quickly obtained—and maintained by careful adjustment of the control knob.

The super-power clarostat illustrated, is also useful in many instances, as a speed control. This giant variable resistor has a high current-carrying capacity. It can be used as a speed control for motors up to ¼ horsepower. Due to its efficient design it dissipates heat very rapidly. In addition to the above-mentioned uses, this resistor may be employed as a line voltage control and as a filament and plate control for transmitters. The super-power clarostat of the "Universal" type, has a resistance range of 200 to 100,000 ohms and a carrying capacity rating of 250 watts.

(Continued on page 316)

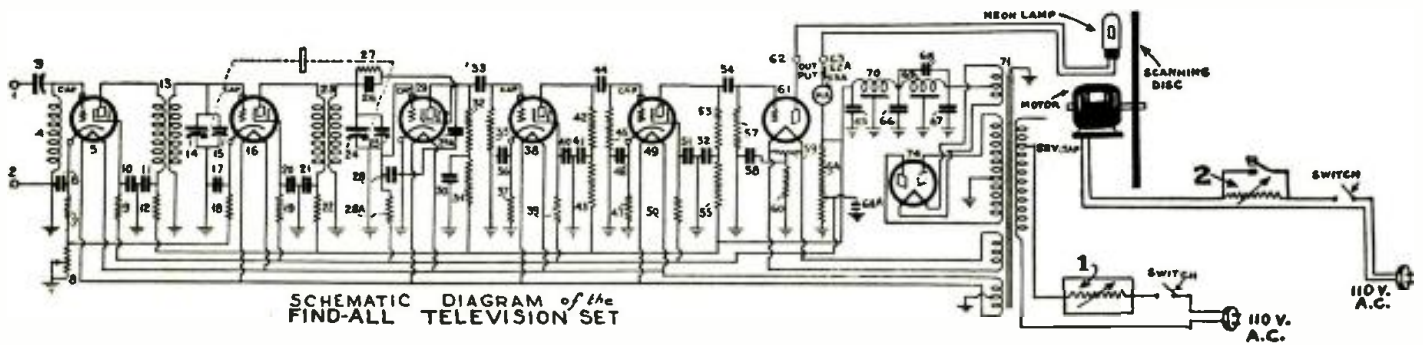

### Detection in Television Receivers

(Continued from page 267)

Ordinary tubes of high internal resistance need on an average a positive grid bias of 12 volts; often one needs a little more, however.

Since this hook-up has worked well, a few hints about its construction will be welcome.

Condensers C1 and C2 are .001-mf. mica-dielectric components. Resistor R should be variable between 0 and 1000 ohms. C3 is a coupling condenser, 0.1-microfarad, feeding into the three-stage audio-frequency amplifier with resistance coupling. Nothing need be said about the hook-up of the latter; since that may be taken for granted as familiar.

The value of the variable resistor R lies chiefly in the fact that, by means of it, the picture's brightness can conveniently be so regulated that the neon lamp illuminates neither too strongly nor too weakly, and consequently gives a good steady picture.

#### Improved Image With Crystal Detector

The favorable results with the above described two-electrode rectifier caused Richardson to make experiments with a still simpler rectifier;

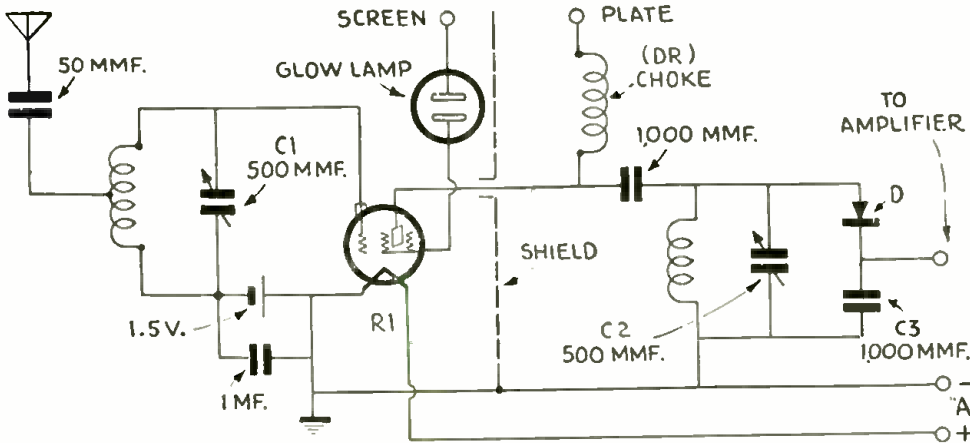

Fig. 4—This circuit furnished the most excellent pictures obtained by Richardson; note the use of the crystal detector D, which must have the right polarity, as reversing the crystal in the circuit, changes the picture from positive to negative, or vice versa. The glow lamp (G1) shown in series with the screen grid circuit, is a small incandescent lamp acting here as a fuse.

namely, a crystal detector, which of course can easily be connected in place of R2 in Fig. 3. It has appeared, from his experiments, that the detector is best placed in the un-grounded side of the tuned circuit, in the plate circuit of the screen-grid tube R1. If one interchanges the detector with condenser C3, then the results become much weaker. It likewise developed that this hook-up (Fig. 4) furnished excellent pictures; "the best," says our source, "which the constructor has ever seen." The whole pictorial surface was clear, and the details of the picture were excellently recognizable; which has caused Richardson to make almost exclusive use of the crystal detector.

justed; finally the two condensers C1 and C2 are tuned until the local station is heard.

When it is certain that the receiver is in order, it can be changed over to television reception (on the broadcast band in Europe); for this the headphones are removed and the audio-frequency amplifier is connected. The heater current for the screen-grid tube and for the amplifier is best taken from the same battery; while it is better to take the plate currents from separate sources.

After looking at the picture, the crystal detector is again adjusted, to seek the most favorable point for reception.—(H. G.) in *Rafa* 1931. H-3.

Please mention TELEVISION NEWS when writing to advertisers

# HERE IT IS—just out!



## TELEVISION

### Its Methods and Uses

by EDGAR H. FELIX

Radio Consultant

276 Pages, 5½ x 8, Illustrated. \$2.50

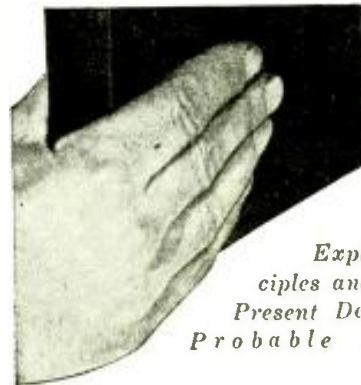

Explains Principles and Practice, Present Development, Probable Future.

HERE is a plain and understandable explanation and discussion of Television today—with a frank and impartial analysis of the problems it faces, its probable future and commercial possibilities. Unnecessary technicalities and scientific verbiage have been avoided as far as possible to make this a practical and readable book for the interested layman, the amateur television and radio experimenter—and for all concerned in any way with the commercial progress of Television.

#### Covers Television Topics Such As:

- has Television really arrived?
- the HOW and WHY of Television.
- how to "act" before the scanning disc.
- unsolved problems of Television.
- possibilities of 100-line system.
- latest synchronizing methods.
- the human eye in Television.
- will future programs come by air or wire?
- new developments affecting receiver design.
- future progress of Television.

—Examine for 10 days Free—

McGraw-Hill Book Co., Inc.  
370 Seventh Ave., N. Y. C.

Send me, postpaid, Felix—Television, for ten days' free examination. I will remit \$2.50 in ten days or return the book postpaid.

Name .....

Home Address .....

City and State .....

Name of Company .....

Position .....

Books on approval in U. S. and Canada only.

# LOOK!

## Hartman Scanner

### \$33.20

24" Scanning Disc

LARGEST and BRIGHTEST PICTURES Developed to Date

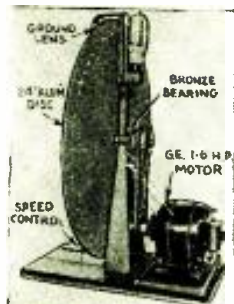

NOW! you can have an improved Television Scanner that can be synchronized on any A.C. line in any city. After years of experimenting our laboratory has developed the simplest method of picture framing. Motor runs constant speed. Disc speed variable and constant by simply turning control knob. PRICE, completely assembled, less motor and lamp

**\$33.20**

- MOTOR—G.E. 1/4 H.P.—1725 R.P.M.—Induction... \$10.50
  - MOTOR—Synchronous—1/6 H.P.—1800 R.P.M.... 17.50
  - NEON LAMPS—1 1/4" Plate..... 3.95
  - SCANNING DISCS—Aluminum—Precision made with 45 or 60 square holes—18"..... 5.50
  - 24"..... 6.50
  - RESISTANCE COUPLED AMPLIFIER for Pilot-Wasp and National sets, etc..... 16.00
- (Uses 2-221's and 2-245's)  
Send Check or Money Order

### HARTMAN LABORATORIES

Subsidiary of DIENELT & EISENHARDT, INC. 1304-18 N. Howard Street Philadelphia, Pa. Established 1874

### Pioneer—Television—Specialist

Flexible Card Board Discs 12" with 45 holes three spiral or 48 holes single spiral for 1/4" shaft \$1.00; 16" with 60 holes single spiral for 1/4" shaft \$1.25; Aluminum Discs 12" with 45 holes three spiral for 3/8" or 1/2" shaft \$6.50; 12" with 48 holes single spiral 3/8" or 1/2" shaft \$6.50; 16" with 60 holes single spiral 3/8" or 1/2" shaft mounting \$7.50. Neon Lamp 1" x 1" plate \$2.50; 6-10 Neon Lamp 75c. Blank Aluminum Disc to drill your own Scanning Discs with 3/8" or 1/2" shaft hole 12" \$1.25; 16" \$1.75. Cast Aluminum Scanning Disc hub with simple clamping arrangement for 3/8" or 1/2" shaft \$1.25. Also make Discs to your specification. Parts needed to make up anything that is suggested in all articles published in this magazine or of your own design may be obtained at reasonable prices. Parts Cast, Machined and Drilled, Wood parts for Cabinets, etc.. Sheet Metal parts, also supply drills, screws, nuts, shafting and rod of any description. What do you need? Send sketch of article. No article too small or large. 48 hour service. Cash, Postal Money Order or Check with your order.

ARTHUR M. POHL

3541 Michigan Avenue Detroit, Mich.

**PATENT**  
YOUR IDEAS REGISTER YOUR TRADE-MARK BY  
**Z. H. POLACHEK**  
1234 BROADWAY  
315 NEW YORK

REG. PATENT ATTORNEY PROF. ENGINEER

CALL or SEND your SKETCH or Simple Model for

CONFIDENTIAL ADVICE

No Charge for Consultation

COUPON

Dear Sir:—Please send me full information and literature about Patent Protection, without obligation.

Name .....

Address .....

**DO IT NOW**

### TELEVISION SPECIALTIES

- 12" Hard Aluminum Disc to make your own scanning disc..... \$1.35
- Duraluminum disc..... \$1.50
- 1 1/2" Magnifying Lens, \$1.25; mounted in aluminum holders..... \$2.35
- Put No. 247 Power Pentode in the last stage of your power amplifier—adapter No. 47, \$1.25; Lynch tubadapter to put two Power Tubes in parallel, \$1.50; Neon Lamps, 650 and 850; Geissler tubes, \$1.50 up; Photo-electric cells, \$4.95; 1 1/2" television neon lamps, \$3.95; Ruhmkorff coils, 5 mm., \$3.95; 50 milliamperes Weston, Model 301, meter, \$3.45; regular price, \$6.00. Short wave coils, \$1.75

**BLAN** The Radio Man, Inc. Dept. TN-4 89 Cortlandt St. New York, N. Y.



## How Shall I Synchronize Better?

By RUDOLF SCHADOW

(Continued from page 300)

(European). The commutator in this case has eight plates; since the disc revolves 12 1/2 times a second, during 100 peaks (50 cycles) of alternating current, and therefore the relay current has to be short-circuited 8 times per revolution.

### Practical Considerations

Some more practical considerations in conclusion:

As already said above, the operation can be accomplished by any motor, which has sufficient power. The transmission between motor and scanning disc-shaft must be such that braking is possible. The braking action is to

when both rest on one plate. Another way is to connect all the commutator segments to the shaft and to make one spring slide on the edge of the commutator and the other on the shaft.

Since the quality of the synchronization obtained depends essentially on the exactness of the commutator, special forms of suitable commutators would be desirable. For instance, it would be very practical to incorporate the commutator with the scanning disc, as shown in Fig. 16. The wheel can be made with the same exactness as the laying out of the disc. Then the disc has thirty more narrow rectangular openings evenly spaced and,

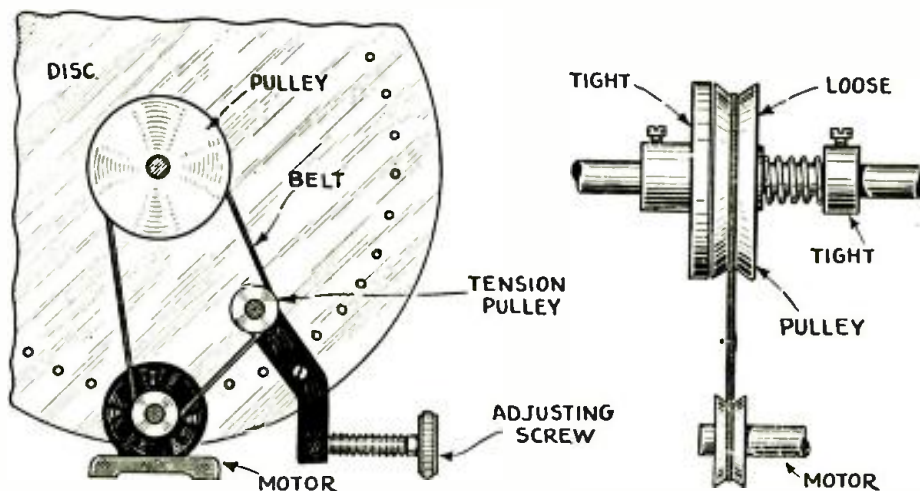

Fig. 15—Desirable method of changing belt tension. together with friction coupling for brake application scheme.

be exerted, not on the motor but on the shaft, which accordingly can only be shared by the motor. For this purpose it is best to use a changeable belt-tightener; or else the distance between the motor pulley and the belt pulley of the scanning disc should be made changeable. It is, however, also possible to set the pulley (of the disc) loose on the shaft of the disc and to make a friction coupling by a spring and an adjustable ring. In Fig. 15, both possibilities are represented; therefore any further description is needless.

With the short-circuit wheel (commutator) the most varied forms are possible. Simplest is the use of a commercial commutator with 30 or 8 segments, as the case may be. The arrangement of the brushes may be such that two sliding springs of different length press against the commutator and are always short-circuited

at a radius of about 2 inches. Into these openings are put pieces of insulating material, which are held fast by a disc 4 to 4.8 inches in diameter, which serves also to strengthen the scanning disc. Contact is made by a spring on the disc and one on the shaft.

Without going into details, I have tried to give a summary of synchronizing devices which, in great part, depend on the principle of relay synchronizing.—Rafa, 1931. H. 4.

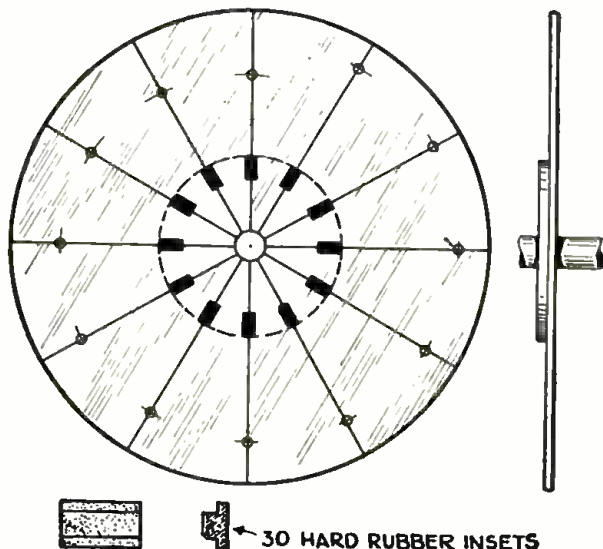

Fig. 16—Nipkow scanning disc provided with commutator, as described by the author.

Please mention TELEVISION NEWS when writing to advertisers

## The New Baird Television and S-W Receiver

(Continued from page 279)

It is important, however, that the transformer *T* and the choke units *CH1* and *CH2* should be mounted so that the terminal lugs point toward the center of the chassis in order to be sure that the relative locations of the terminals will be such as to make the proper connections as shown on the wiring diagrams.

It is also important to bend up the terminals of both the transformer *T* and the double choke unit *CH1* and *CH2* so as to be sure that they clear the edges of the holes in the chassis and that there will be no danger of the wires leading to such terminals shorting to the chassis.

The set screws provided with condensers *C4* and *C7* should be removed to prevent any possibility of binding as the condensers are operated.

Condensers *C18*, *C19*, *C20*, *C21*, *C22* and *C23* are all contained in a single can with their common leads grounded to the can. All of the capacities in the can are equal and have the same voltage ratings. Pairs of leads from this condenser block should be twisted as shown in the diagram, Fig. 7.

Condensers *C24*, *C25*, *C26* and *C27* are furnished in one block, with their common leads grounded to the can. Condenser *C24* (red lead) is a higher capacity than the other in the block and should be connected as indicated in the diagram. Condensers *C25*, *C26* and *C27* are of equal capacity and are provided with blue leads which should be connected as shown.

In the case of condensers *C1*, *C2*, *C3*, *C4*, *C5*, *C6*, *C7*, *C18*, *C19*, *C20*, *C21*, *C22*, *C23*, *C24*, *C25*, *C26*, *C27*, *C31* and *C32*, the connection to ground (chassis) is automatically made when the units are mounted.

This is also the case with the *Gnd* binding post terminal, the mounting strip of resistors *R5* to *R14* inclusive and the frame terminals of jacks *J1* and *J2*.

The *G* numbers, *G1*, *G2*, etc., indicate grounded connections made through the chassis.

The *H* numbers indicate holes in the chassis or shields through which wires are passed to make connections between terminals on one side of the chassis or shields and terminals on the other side. These holes are marked with corresponding numbers on both sides of the chassis to indicate that the wires which pass through them continue to their respective terminals on both sides of the chassis.

### Wiring the Receiver

In wiring, it is a good plan to make all the connections which go to the ground (chassis) first. Then wire up the filament leads being very careful to make the connections to the transformer terminals properly as indicated in the wiring diagram, Fig. 7. The heavy wire should be used for the filament leads and the filament wires should be run in twisted pairs.

The ground connections to resistors *R5*, *R7*, *R8*, *R10*, *R11*, *R13* and *R14* are made easily by soldering one of the pigtail leads from each resistor mentioned to the metal mounting strip of the resistor assembly.

In wiring the radio frequency transformer units, all the wiring of the elements around the sockets should be made first and long leads should be provided for the leads which are to be brought out through the shields. These wires can then be run through the holes provided in the shields and the cylindrical portions of the shield can be fitted to the bases by means of the bayonet joint provisions made in the base and shields. The *P* and *F2* terminals of socket *S10* are not used.

The balance of the wiring is so clearly shown in Figs. 6 and 7 that it is not necessary to describe the wiring in detail.

### Operation of Receiver for Short Waves

The first step, preparatory to operating the receiver is to insert the proper tubes in the various sockets. Type —24 AC screen grid tubes *VT1*, *VT2* and *VT3* should be inserted in sockets *S1*, *S2* and *S3* and the tube shields should then be placed over

**CLAROSTAT**

## TELEVISION and SHORT WAVE CONTROLS

### SPEED CONTROL CLAROSTAT



for SCANNING DISC CONTROL and Heavy Duty laboratory use.

### STANDARD CLAROSTAT

for KINO LAMP CONTROL REGENERATION CONTROL PLATE VOLTAGE CONTROL



### CLAROSTAT WIRE WOUND POTENTIOMETER

for VOLUME CONTROL Synchronizing Control Regeneration Control Bias and Plate Voltage



### CLAROSTAT GRAPHITE ELEMENT POTENTIOMETER



for Volume Control Oscillation Control Tone Control

Write for Literature Mention Television News

Clarostat Mfg. Co., Inc.  
285 N. 6th St. Brooklyn, N. Y.

## QUALITY TELEVISION APPARATUS

AT BARGAIN PRICES  
SHORT WAVE TRANSMITTING and RECEIVING PARTS

HARRISON RADIO CO.  
189 Franklin St. - Dept. V - N. Y. C.

## TELEVISION

Enroll in our new TELEVISION COURSE that opens this fall. Competent instructors — reasonable rates.

WEST SIDE Y. M. C. A.  
RADIO-TELEVISION INSTITUTE  
115 W. 64th Street New York

# Radio's Latest Books on Servicing

**Official Radio Service Manual  
and Complete Directory of All  
Commercial Wiring Diagrams**  
Edited by HUGO GERNSBACK

**Radio Service Man's Handybook**  
With Addenda Data Sheets

THE OFFICIAL RADIO SERVICE MANUAL is the greatest achievement ever attempted in the Radio Service Field. It is not only the OFFICIAL RADIO SERVICE MANUAL and Complete Directory of all Commercial Wiring Diagrams, but it contains a complete and comprehensive course of instruction for radio service men. Just off the press and more than 30,000 copies sold. And why not, when it fills such a universal need among Manufacturers, Jobbers, Dealers, Service Men and all interested in radio? The OFFICIAL RADIO SERVICE MANUAL is complete and gives you every circuit of every set manufactured of which there is any information. Its looseleaf and flexible leatherette covers enable additional servicing data to be added periodically. There are hundreds of time-saving kinks which will help to increase your business and profits.

As the NEW YORK SUN says, "It is difficult to see how any service man can conduct his business satisfactorily and efficiently without this 350-page volume."

Hundreds of diagrams,  
200 pages, 9 x 12 inches



\$2.00

\$3.50

Over 1,000 Diagrams and  
Illustrations — 352 Pages

The RADIO SERVICE MAN'S HANDBOOK contains a tremendous amount of authentic material and practical information on Modernizing old receivers; Servicing obsolete sets; Repairing power packs; Construction of test laboratory equipment; Vacuum tubes; Set testing with analysers and hundreds of other similar subjects. Among the contributors are Bertram M. Freed, Leon I. Adelman, Paul L. Welker, Sylvan Harris, C. W. Palmer and others.

The HANDBOOK enables service men to record notes, diagrams and charts on the special 45-page section of specially ruled sheets included in the book. Over 200 pages in all—size 9 x 12 inches.

▶ **BOTH BOOKS** for \$5.00 ◀  
Mail Coupon TODAY!

GERNSBACK PUBLICATIONS, Inc. TN-4  
96-98 Park Place, New York, N. Y.  
I enclose herewith check or money order for \$.....  
for which you are to send me postage prepaid the  
( ) Official Radio Service Manual.....\$3.50  
( ) Radio Service Man's Handybook..... 2.00  
OR BOTH BOOKS FOR \$5.00.

Name .....

Address .....

City .....

State .....

them and fitted to the tube shield bases. The cap terminals from the radio frequency transformers should then be fitted over the top terminals of the screen grid tubes.

Type —27 heater type AC tubes VT4 and VT5 should be inserted into sockets S4 and S5, and a Type —45 power tube, VT6, should be placed in socket S6. A Type BH rectifier RT should be placed in socket S8.

The speaker cord tips should be inserted in the Speaker tip jacks of the receiver.

The ground wire should be connected to the Gnd binding post. When using the receiver for short-wave and television reception, the antenna wire should be connected with the Short Ant. binding post. When using the receiver on the broadcast waveband, it is usually better to connect the antenna to the Long Ant. binding post.

A set of three coils is used in the receiver for any given wavelength range—one in the first R. F. stage socket S9 for coupling the antenna to the first R. F. tube, a second in socket S10 for coupling the first R. F. tube to the second R. F. tube and a third in socket S11 for coupling the second R. F. tube to the detector. The Octocoils used to cover any given wavelength range are distinguished by the colors of the forms on which they are wound. The GREEN Octocoils cover the range from 16 to 30 meters. The BROWN Octocoils cover the range from 29 to 58 meters. The BLUE Octocoils cover the range from 54 to 100 meters. The RED Octocoils cover the range from 100 to 200 meters. Octocoils are also available to extend the range into the broadcast band above 200 meters.

For Television reception it is necessary to use regular RED Octocoils in sockets S9 and S10 and the Television, (single winding RED Octocoil) in socket S11.

When the Television (single-winding) Octocoil is used in socket S11, the regenerative circuit (shown in dotted lines) is opened, thus providing the non-regenerative circuit required for Television reception.

For regular short-wave reception on 100 to 200 meters, place regular RED Octocoils in sockets S9 and S11, and the Television (single-winding) Octocoil in Socket S10. For other wavelengths use the three coils of the proper color in all three sockets, S9, S10 and S11.

The AC plug of the receiver should, of course, be inserted in a lighting outlet, supplying 110-volt, 60-cycle AC power and the proper coils should be in the sockets S9, S10 and S11.

To tune in a signal, turn the knob of potentiometer P as far as it will go in a clockwise direction. This will automatically snap on the AC switch and will also put a fairly high voltage on the screen grids of tubes VT1 and VT2.

Switch S1 should be thrown to the On or Grid Rectification position. With the switch on, or in the closed position, the grid bias resistor R5 in the detector grid circuit is shorted out and the detector operates as a grid rectification detector. For Television operation or for use on very strong signals, it is advisable to throw the switch to the Off or plate rectification position. In that case the detector operates as a power detector and is capable of handling a stronger signal without distortion. The use of plate rectification also damps the tendency toward regeneration and is therefore preferable when using the receiver for Television. Grid rectification, however, provides greater sensitivity and better regeneration so that it is desirable to use the switch in the On position when tuning in distant short-wave stations.

For loudspeaker reception, the switch SW3 should be thrown to the Hi or Speaker position, thus connecting the speaker across the output choke CH2.

For Television reception, switch SW3 should be thrown to the Lo or Television position, thus switching the output of the power tube of the receiver to the input of the Television Unit.

With the receiver connected to the lighting outlet and the regular regenerative coil in socket S11, the potentiometer turned fully on in a clockwise direction, switch SW1 thrown to the On or Grid Rectification position and switch SW3 thrown to the Hi or Speaker position, the receiver is ready to be tuned to a shortwave station for adjusting the tuning and trimmer condensers.

First line up the main sections of the variable gang condensers and tighten the set screws on the shaft.

Then let out the adjusting screws on the trimmer condensers C5 and C6 of the tuning condenser sections C2 and C3 respectively, and adjust trimmer condenser C4 to about its midposition (half-meshed).

## Continental Television Corp.

A NEW television concern, the Continental Television Corp, with offices at 127 South 15th St., Newark, N. J., has just been organized. Its officers are: Joseph Leopold, President; John Fettig, Vice-President; Paul R. Nachemson, Vice-President; E. Girard Schmidt, Secretary and Treasurer. John Fettig and Paul Nachemson, formerly with Radiotechnic Laboratories, are in charge of engineering and research. Besides the kit on which they are going into production shortly, they intend to bring out a projection outfit, which will throw the image on a screen.

The Gold Seal Electrical Co., also of Newark, whose president is Mr. William E. Duff, are national distributors for the line and report that the trade has shown a keen interest in television.

Please mention TELEVISION NEWS when writing to advertisers

### All About the Kerr Cell

(Continued from page 280)

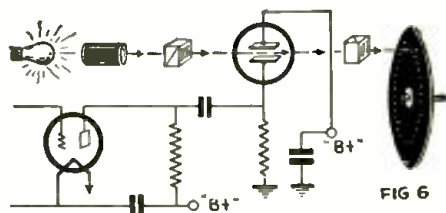
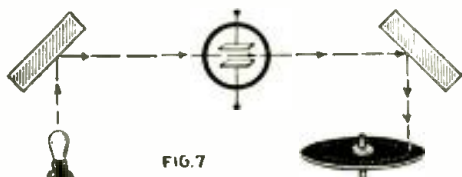

Fig. 6—Arrangement of Kerr cell in output circuit of a television amplifier. Fig.



7—How home-made polarizers can be arranged in respect to the Kerr cell.

Zeiss, 499 5th Ave., N. Y. C. The nitrobenzene can be obtained in a

pure state from any technical supply house.

#### Cheap Home-Made Polarizers

There are, of course, other and cheaper means of polarizing light, though not many so efficient. If a pile of glass plates—microscope slides—about 12 deep be set so that the light is incident at an angle of about 67 degrees, as shown in Fig. 7, the reflected light will be found to be plane polarized. A second and similar pile may be used as the analyzer. Disposition of the Kerr cell between the two in the path of the ray will result in modulation of the light transmitted, in accordance with the applied signal. The Kerr cell and its near relatives are fertile subjects for experiment; and the student undertaking a serious study of them has an opportunity to make a name for himself in the world of science.

### New Helical Mirror for Television Scanning

(Continued from page 271)

so constructed that they can be operated to scan a field either with a steady beam of light, or with an interrupted beam of light.

The reflecting and scanning apparatus (see patent drawing, Fig. 6), includes a neon lamp 15 and lens 16 for directing the light onto the helical mirror 17, from where it is reflected to and over the field 18, by rotation of the mirror. From the field the reflector, if visualized, would appear to be a stationary rectangular mirror, in which the image reflected by the lamp would be clearly visible, while in reality the image would be reflected point by point in vertical lines that progress from side to side of the field, and also from end to end of each unit of the rotating apparatus.

#### Mirror Can Be Revolved In Any Manner

The helical mirror can be revolved in any desired manner. For the purpose of illustration it is shown provided with a shaft 19 that is rotated by the motor 20, that can be driven in any well-known way. The helical mirror 17, is made up of a number of units 21, that are preferably rectangular, as shown in Figs. 1 to 5, inclusive, but can be of different forms, as illustrated in Figs. 6 to 9 inclusive. The units 21 are arranged on the shaft 19 and secured between the opposing nuts, 22, 23, so that when properly assembled they are held in a relatively fixed position on the shaft, and the arrangement is such that they form a helix of a single turn.

Each unit is provided with a mirror edge 24, preferably treated to form a single surface mirror and has its other edge 25 and ends 26, 27 blackened or

treated so that they are not reflectors of light, so that only the mirror edges 24 reflect the light from the lamp 15 to the field 18. The units are arranged so that they form a composite helical mirror which, when rotated, reflect beams of light in a consecutive order to scan the field 18.

In other words each unit is mounted and secured on the shaft, so its mirror edge is close to and arranged tangentially to longitudinal axis of the shaft, and also arranged in stepped relationship to one another, so that they form a helix, which—when rotated, causes a ray of light from a lamp to move over each mirror edge, from end to end and progressively from end to end of the helix.

#### Rotation In Either Direction

The helical mirror, as previously explained, can be rotated in either direction, as indicated by the arrows in Fig. 2.

When the scanning appliance is operated with the helical mirror moving in the direction of the arrow —a—, the vertical lines 30 indicated by dotted lines in the field 18, will begin at the top of the field and extend downward and the other direction of movement will be from the right to the left of the field. When the mirror is reversely rotated, as in the direction of the arrow —b—, the vertical lines will begin at the bottom of the field and extend upwardly and the other movement will be from the left to the right of the field, and in this movement the reflected light will move from end to end of each mirror edge, and from end to end of the helix, as above mentioned. The helical mirror can be arranged in any desired

# Watch for FUTURE JENKINS Announcements

Jenkins Television Corp.  
Passaic New Jersey

Be sure to read the  
**IMPORTANT MESSAGE**  
on page 316, which tells how  
to read  
**TELEVISION NEWS**  
at a Big Saving

**WORLD-WIDE**  
**SHORT WAVE RECEIVER**  
Span the World with this Set!

A new radio thrill for you! Listen in DIRECT to London, Paris, Berlin, Buenos Aires and other broadcasting stations throughout the world via short waves. Enjoy unique foreign programs from strange lands. Your ordinary receiver cannot tune in these low wave stations. **WORLD-WIDE RECEIVER** gets 14 to 550 meter stations with surprising clarity. **SEND NO MONEY!** Just write your name and address on a postcard and ask us to send you this wonderful guaranteed short wave set. Pay postman \$6.45 plus a small delivery charge. All orders West of Rockies must be accompanied by \$1.00 deposit. Price in foreign countries \$7.75 delivered. Order today!

#### NEW RADIO BARGAINS

Low Power Transmitter adaptable for phone or code. With plug-in coils ..... \$14.75  
B Eliminator, Bone Dry, with 280 tube, 150 volts, will operate up to ten tube set, fully guaranteed. 6.75  
AC—A B C power packs, completely assembled..... 8.75  
Tubes: UX type, 30-day replacement guarantee, No. 210, \$2.25; No. 250, \$2.45; No. 281, \$1.85; No. 245, \$1.25; No. 224, \$1.25; No. 227, 75c; No. 226, 65c; No. 171, 75c.  
International Microphone, two-button, for public address systems and transmitters, speech or music... \$9.75

WRITE FOR BARGAIN CATALOG  
CHAS. HOODWIN CO.

4240 Lincoln Ave., Dept. H-18, CHICAGO

Please mention TELEVISION NEWS when writing to advertisers

**"The SHORT WAVE  
IS THE MOST IMPORTANT THING  
in Radio"**

*Giuglielmo Marconi*

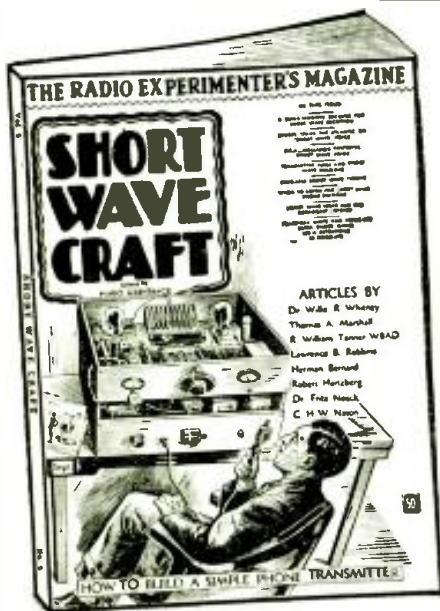

**R**APIDLY increasing each day are the number of experiments in the Short-Wave field—developments which are bringing to this branch of radio thousands of new "thrill seekers." Experimenters, as in the early days of Radio, again have the opportunity to bring about stirring new inventions. Read in **SHORT WAVE CRAFT**, the *Experimenter's Magazine*, how you can build your own Short-Wave Sets, both transmitters and receivers. **SHORT WAVE CRAFT** is exclusively a short-wave magazine—the kind you have wished for so long.

**Regular Departments in  
SHORT WAVE CRAFT**

PHOTOGRAPHIC SECTION—PICTURES OF LATEST SHORT-WAVE SETS AND STATIONS.  
TRANSMITTERS FOR SHORT WAVES AND HOW TO BUILD THEM.

ON ALL LARGE NEWSSTANDS

4-Color Cover  
9" x 12" in Size  
Over 200 Illustrations

THE SHORT-WAVE EXPERIMENTER  
TELEVISION ON SHORT-WAVE  
AIRCRAFT SHORT-WAVE SETS  
HOW TO BUILD SHORT-WAVE AERIALS  
SHORT-WAVE QUESTION BOX

**A FEW OF THE MANY INTERESTING ARTICLES  
IN THE CURRENT ISSUE**

- "P. C. J."—HOLLAND SPEAKING
- EUROPE SPANS THE ATLANTIC ON SHORT WAVES
- BAIRD COMBINATION SHORT-WAVE AND TELEVISION RECEIVER
- THE COLIN B. KENNEDY SHORT-WAVE CONVERTER
- SCOTT "ALL-WAVE" SUPER-HET, PROVIDES WORLD-WIDE RECEPTION
- TRANSMITTING TUBES TO FIT YOUR SHORT-WAVE PROBLEM
- A LOW-COST PUSH-PULL C-W TRANSMITTER
- A "FIVE METER" RECEIVER
- HOW TO BUILD YOUR OWN "PHONE" TRANSMITTER
- SHORT-WAVE TUNING—LESS PLUG-IN COILS
- EXPERIMENTS WITH SIMPLIFIED REMOTE CONTROL
- WINNERS IN \$2,000 AMATEUR STATION CONTEST
- WHEN TO LISTEN IN
- SHORT WAVE STATIONS OF THE WORLD

**Full Details in Coupon About Special Offer**

SHORT WAVE CRAFT, 98 Park Place, New York, N. Y. TN-4

I enclose herewith my remittance of \$2.00 (Canada and Foreign \$2.50), check or money order preferred, for which you are to enter my subscription to **SHORT WAVE CRAFT** for One Year, and also send me the last two issues gratis. I understand that the regular subscription rate is \$3.00 and this offer will be void after September 30th. **SHORT WAVE CRAFT** is published every other month.

Name .....

Address .....

City..... State.....

position and can have a multiplicity of mirror surfaces.

When the helical mirror is made up of units such as are shown in Figs. 6 to 9 inclusive, it is operated in substantially the same way as indicated in Figs. 1 to 5 inclusive.

If desired the helical mirror 17 can be made up of units 21 of the form shown in Figs. 8 and 9, in which instance only a part of the edge 24 of each unit is a mirror.

The apparatus as here described is also adaptable for use in telephoto, radio-photo and telegraphy, as well as in television. In operation the lamp 15, lens 16, helical mirror 17 and field 18 are properly arranged as indicated in Fig. 1. Then the mirror is rotated as above described to reflect the light beam from the lamp 15 to the field 18, which is completely scanned in two directions at each revolution of the mirror.

**Y. M. C. A. Television  
Course Ready**

*(Continued from page 283)*

pecially, the experimenters of this modern era. The vast laboratories of the radio industry are concentrating the energy of their engineers on improvements and refinements in perfecting television. The West Side Y. M. C. A. Radio-Institute has pioneered in the field of radio for fifteen years, and it has been one of the first schools to take advantage of new discoveries as they were made, in order to give its students a thorough training. Previous to this, in the early stages of the automobile, this Association was the first to establish educational courses in automobile mechanics, which have for many years been well known as the West Side Y. M. C. A. Automobile School."

The job of the new Radio-Television Institute will be to teach thoroughly the operating technique of many of the problems involved in the field of television. It will instruct, with complete theoretical outline, in the principles underlying the functions of the entire system, both broadcasting and receiving. Demonstrations will be given in the classroom laboratory on a complete transmitting and receiving set which will be available. Later on, as the demand arises, servicing courses will be offered.

The chief instructor of the courses will be Mr. Harry Higginbottom, chief engineer of the Jenkins television transmitter, which is located in New York City; Mr. Higginbottom is well known in this field. At first, instruction will be given evenings only. Requirements for entering this school will be the satisfactory completion of a course in radio mechanics, or an oral examination by a television instructor who will judge the prospective student's fitness to take this advance study.

Please mention TELEVISION NEWS when writing to advertisers



## Television—Today and Tomorrow

By DAVID SARNOFF

(Continued from page 251)

new instrumentalities serves only to emphasize the importance and to increase the necessity for these two vital elements:

First, the creative element; the domain of the author, the playwright, the composer. The man or woman who has a story to tell or a song to compose will be in demand so long as the art of entertainment endures;

Second, the human interpretation of the creator's work. Someone must speak the playwright's words before they can be placed upon the screen, the radio or the phonograph record; someone must interpret the composer's music before it can come to life through any of the mechanical devices of the electrical era.

These are not the requirements of a day, a week or a year; they are the permanent elements of the entertainment arts. Television, when it arrives as a factor in the field of entertainment, will create a fresh market for this fuel; it will give new wings to the talents of creative and interpretive genius; and it will furnish a new and greater outlet for artistic expression. All this will stimulate and further advance the art of motion-picture production.

### Television's Potential Audience

The potential audience of television in its ultimate development may reasonably be expected to be limited only by the population of the earth itself.

Since the dawn of the new era of electrical entertainment, untold millions have been added to our audiences. It is interesting to compare the opportunities of this new era with those of the past. The life-time audience of Demosthenes was not as great as a one-night audience of Amos 'n Andy. Napoleon and Kaiser Wilhelm, showing themselves in their splendid regalia before all their spectators, never in their lives were seen by as many eyes as saw Richard Dix in "Cimarron". The sound of all the guns and cannons, fired in all the wars since the dawn of time, did not reach as many ears as does the crow of the proud Pathé rooster on the talking screen.

This vast increase in the entertainment audience has been made possible by the introduction of modern science into the older arts. And now television will come to open new channels, to provide new opportunities for art and the artist and to create new services for the audiences of all the world.

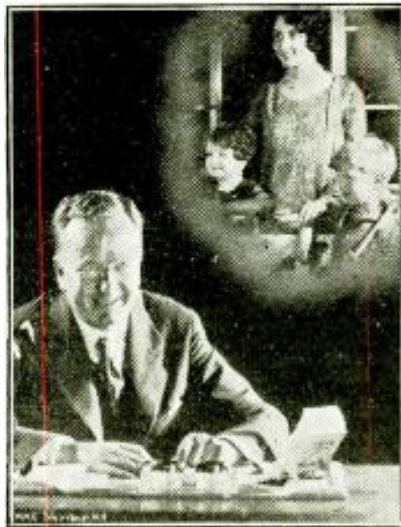

## What Wouldn't You Do for Them

**Y**ET you may be overlooking the most vital thing of all for their future security and happiness—**MONEY.**

If you were taken away tomorrow, what would they have to live on? Could the children go on through school? Could mother earn enough for them?

Life insurance is now sold by mail at so small a cost **NO ONE** need be without its splendid protection. We now offer a special old line, legal reserve life policy for as low as \$4.13 at age 35 (other ages in proportion)—a policy paying you \$1,000, with an additional \$5,000 special travel accident benefit; disability benefits, loan values, and other advantages. Think of it! No family can afford to be without such protection, at so trifling a cost.

We sell entirely by mail, hence these savings—no agents' commissions, no medical fees, no extras, no red tape. **YOU** save the difference.

Mail the coupon below. We will send you a free sample policy which you can judge for yourself. If you like it, keep it. If you don't, there's not a cent of cost or obligation.

For your own peace of mind, for the security of those you love, get this low-cost protection while you **CAN.** Mail the coupon now.

**FREE! Mail this coupon TODAY for sample policy and complete details.**

Union Mutual Life Company of Iowa,  
Des Moines, Iowa.

(Box 214)

Send me above described Free sample policy and complete details—this is not to obligate me in any way.

Name \_\_\_\_\_

Address \_\_\_\_\_

Age \_\_\_\_\_ Occupation \_\_\_\_\_

**IF YOU ARE LOOKING FOR RADIO OR TELEVISION BOOKS WHICH WILL BE HELPFUL TO YOU, AND WHICH YOU CAN READ DURING YOUR SPARE TIME, THEN READ THE ANNOUNCEMENT ON PAGE 320.**

### TELEVISION CALLING FOR MEN

Television is here. Slight programs are now being received! Learn quickly to operate the "Eyes of Radio." Trained operators, salesmen, service and repair men are needed now. No one can hope to compete for big pay jobs without proper training. Under my personal supervision you master the essentials of Television in a few short weeks, right here in my shops and practical laboratories. Get into the real money—quick. Thousands of fortunes were made in Radio 10 years ago—now is your opportunity to cash in on the world's greatest future industry.

**FREE!** Send name and address for fascinating new book, "Practical Television"; profusely illustrated; contains a vast fund of vital information. Don't miss it. It's free. Write for it today.

"SID" NOEL, Pres.

First National Television, Inc.  
(School Division)  
109 Fairfax Airport, Kansas City, Kansas

## AUTO RADIO

Long Distance Receiver

**Amazing Low Price!**  
**Quality Performance**

Six tube triple screen-grid using 3-224, 2-227 and 1-245 power tube. Easy to install. Will fit any car. Single dial control. We guarantee that this set will pull in stations within a radius of 1,000 miles and that it will deliver the volume and tone qualities of an electric set, or your money refunded.

**PRICE OF SET ONLY \$20.00**

Price Complete, including tubes, batteries, dynamic speaker and suppressors, all ready to install and use, \$39.50. Send \$5.00 deposit with order, balance C.O.D. On foreign orders remittance in full required. **ORDER TODAY.**

**CHAS. HOODWIN CO.**  
4240 Lincoln Avenue, Dept. H-180 Chicago, Illinois

Please mention TELEVISION NEWS when writing to advertisers



**LIKE ENTERING THE HOME OF A GOOD FRIEND WHEN YOU REGISTER**

**COME DOWN BY THE SEA**

Get Health and Happiness at This Splendidly Conducted Hotel—Close to Boardwalk and Steel Pier.

European Plan Rates per Day: Single, with Running Water, \$2.00 and \$2.50. Double, \$4.00 and \$4.50. With Private Bath: Single \$2.50 and \$3.00; Double, \$5.00 to \$7.00. Special Weekly Rates.

A la Carte Restaurant Service at Moderate Prices—Best of Food. Attentive Service—Courtesy—Politeness—and Satisfaction Assured. You Go Home Happier for Having Been a Franklin Guest.

*Bathing Direct from the Hotel*

**FINEST AND BEST PROTECTED BEACH IN THE WORLD**

MILTON S. LINDSAY  
PROPRIETOR

**HOTEL FRANKLIN**  
SOUTH VIRGINIA AVENUE—NEAR THE BEACH  
ATLANTIC CITY, N. J.

**WELCOME to**  
NEW YORK and  
The **HOTEL**  
**GOVERNOR**  
**LINTON**

31<sup>ST.</sup> ST. AND 7<sup>TH.</sup> AVE.  
opposite PENNA. R.R. STATION,



1200 Rooms each  
with Bath, Servitor and Circulating Ice Water.

**ROOM AND BATH 3<sup>00</sup> UP**

**The Home Hotel**  
of New York

Homelike in service, appointments and location... away from noise and congestion, yet but a few minutes from Times Square... garage facilities for tourists.

Room and Bath from  
\$3 single \$4 double  
500 Rooms

Home folks will  
like this hotel

**HOTEL**

**BRETTON HALL**  
BROADWAY at 86th ST.  
**NEW YORK**

*Back Issues of TELEVISION NEWS*

for Reference Work or to complete your files of Television Data, can still be had at the regular price of Fifty Cents per copy. Send check or money order to

**TELEVISION NEWS**  
98 Park Place  
New York, N. Y.

**What May the Public Expect from Television?**

The instantaneous projection through space, of light-images produced directly from objects in the studio, or the scene brought to the studio by remote control, involves many problems. Special types of distribution networks, new forms of stagecraft, and a development of studio equipment and technique will be required. With these must come a new and greater service of broadcasting, both of sight and sound. A new world of educational and cultural opportunities will be opened to the home. New forms of artistry will be encouraged and developed. Variety, and more variety, will be the demand of the day. The ear might be content with the oft-repeated song; the eye would be impatient with the twice-repeated scene. The service will demand, therefore, a constant succession of personalities, a vast array of talent, a tremendous store of material, a great variety of scene and background.

There is little in the field of cultural education that cannot be visioned for the home through the new facilities of electrical communication. Assume sufficient progress in the television art; and every home equipped for radio reception may, at certain times, become an art gallery. The great works of painting and sculpture in the art galleries of Europe and America lie buried there, so far as the vast majority of the earth's population is concerned. Television, advanced to the stage when color as well as shadow may be faithfully transmitted, would bring these treasures vividly to the home. Conceive the exhibition of such works of art in the home, accompanied by comments and explanations by the proper authorities. Just as sound broadcasting has brought a new sense of musical appreciation to millions of people, so may television open a new era of art appreciation.

But even more appealing to the individual, is the hope that television may, at least in a measure, enable man to keep pace with his thoughts. The human being has been created with a mind that can encompass the whole world within the fraction of a second; yet his physical senses lag woefully behind. With his feet, he can walk only a limited distance. With his hands, he can touch only what is within reach. His eyes can see at a limited range, and his ears are useful at a short distance only.

When television has fulfilled its ultimate destiny, man's sense of physical limitation will be swept away, and his boundaries of sight and hearing will be the limits of the earth itself. With this may come a new horizon, a new philosophy, a new sense of freedom, and greatest of all, perhaps, a finer and broader understanding between all the peoples of the world.

*Please mention TELEVISION NEWS when writing to advertisers*

## How We Received "W3XK" in Kansas

By C. BRADNER BROWN

(Continued from page 269)

in Fig. 4. No dimensions are given; because every experimenter has to work with different material. Care should be taken in adjusting the clearance between the gear and the core.\*\* This should be made as small as possible without binding. In all cases, a small hole was drilled before sinking the wood-screws used; this prevents splitting of the end grain and assures a tight fit, for the screws can be driven home easily.

The photograph reproduced here does not show the construction of the motor very well, and was taken only to show the arrangement of the con-

trol and the meter used for reading the current passing through the neon tube. The optical system is shown in sketch. Its arrangement is such that the picture appears sideways in the aperture; this, however, is inconvenient and the window was placed in this position only to accommodate the necessary lens which we had at hand.

\* The number of teeth must be the same as the number of holes used in the scanning disc. W3XK now uses 60 holes and 20 frames per second.

\*\* The two magnet poles of the synchronizing motor should be mounted on a yoke or lever, which permits the operator to rotate them through any part of a circle, in order to "frame" the image.—Editor.

## The Barthelemy System

(Continued from page 303)

dreds of people who besieged the doors.

Can it be said that the distinguished engineer has solved the problem of seeing at a distance as the public understands it—that is to say, the transmission of a large and distinct image by natural light? Undoubtedly not. We saw, in the red color of neon, an indistinct, very jumpy image, of people who were moving within a yard of the transmitting apparatus.

Those who understand the enormous difficulties of the problem understood that Mr. Barthélémy has made improvements, which were not all to be shown at that demonstration. He was then working on a band of 40-kilocycle width, which he will increase, it appears, to 150 kilocycles, to

give images with better detail. The transmitter was located at Montrouge, three-fifths of a mile from the receiver.

His greatest development is the synchronism of the motors, which is effected by signals lasting only one thousandth of a second, impressed on the same carrier wave. He has also increased the brightness and size of the image, which reaches 155 to 185 square inches.

The images moved on the screen, at the same time that their voices were heard from the loud speaker.

For laymen, the reproduction was deceptive; but it showed, nevertheless, a great technical improvement over foreign systems.—*Le Journal (Paris)*.

## How We Staged the World's First Television Plays

By WILLIAM J. TONESKI

(Continued from page 263)

### Producing the Second Television Drama

It seems that the engineers profited greatly from this broadcast; for when the first rehearsal was called in staging the second television drama, eight months later, we were amazed at the progress made. The twelve-inch frame, showing only the head of the actor was now replaced by an eight-foot stage. For the second play we chose "Torches," by Kenneth Raisbeck, because it requires the use of only three characters. The play was divided into three parts, each of which was produced with a different number of picture elements: Part 1 with 48 x 48; Part 2 with 60 x 72; Part 3 with 80 x 80.

Because the action of the play took place on a stage which was eight feet wide by eight feet high by six feet deep, costumes and scenery had to be used. The lessons learned in the first broadcast proved of great value. No longer were we forced to experiment with colors for painting the scenery.

A large dull gray background with an archway in the middle was constructed for the scene, showing the interior of the house. The pale sky seen through the arch was an unpainted beaverboard screen, placed about two feet behind the scene. Two torches, (from which the play gets its name) were placed one on each side of the arch. We mounted small fan motors in the tops of the torches so that, when ribbons were tied to the frames and the fans were started, we obtained the effect of flames.

All the actors wore costumes which were either black or dark green, trimmed with dull gold braid. The make-up was much simpler; since the focal range of the camera was so increased that no distortion resulted from shadows.

### Full Size Figures Reproduced

As the curtain rose on the first scene of "Torches" the full figures of of the actors were seen by the audience. Fig. C shows the arrangement of the equipment for this broadcast.

## One in a Thousand



At 999 hotels in Atlantic City you can get the same thing . . . rooms with or without meals . . .

"An Original and Unique Service has made

## THE CAROLINA CREST

The Thousandth Hotel

\*Abed or at your service table enjoy a delicious Tray Breakfast WITHOUT CHARGE—in the privacy of your own comfortable room—while you glance through your morning paper . . . then wonder as all our guests do—how we happened to move your home to the

## CAROLINA CREST

North Carolina Avenue near Boardwalk ATLANTIC CITY, N. J.

### SUMMER RATES

Single—\$5 and \$6  
Double—\$8 and \$10

Every Room with Private Bath

IT'S WISE TO MAKE RESERVATIONS IN ADVANCE

## QUIT TOBACCO



No man or woman can escape the harmful effects of tobacco. Don't try to banish unaided the hold tobacco has upon you. Join the thousands of inveterate tobacco users that have found it easy to quit with the aid of the Keeley Treatment.

## KEELEY Treatment For Tobacco Habit Successful For Over 50 Years

Quickly banishes all craving for tobacco. Write today for Free Book telling how to quickly Free yourself from the tobacco habit and our Money Back Guarantee.

**THE KEELEY INSTITUTE**  
Dept. O-501 Dwight, Illinois

# This Offer Saves You \$2.00

Until the 30th of September this opportunity is yours—this chance to read radio's two great magazines, TELEVISION NEWS and RADIO-CRAFT, at a saving of \$2.00.

Regularly the rate for one year's subscription to TELEVISION NEWS is \$3.00 and for eight months of RADIO-CRAFT—\$2.00. For a brief period only, our readers can enter their subscription to receive both magazines for \$3.00. This is a reduction of 40% and represents a saving of \$2.00.

TELEVISION NEWS you have read, and it is needless for us to say that you are well pleased and want to read every issue. It is the "Town Crier" of new developments in the television field.

And RADIO-CRAFT, also edited by Hugo Gernsback, is the radio magazine selected by the greatest number of service men, dealers and radiotricians. Of course, thousands of amateurs read RADIO-CRAFT, too. Each month, men of outstanding prominence in the radio field contribute articles of real interest to all. Here is a summary of articles usually found in each issue: Service Men's Department—Radio Service Data Sheets—New Developments—Radio Construction and Theory—Kinks and Information Bureau—Tubes and Their New Design—etc.

Clip the coupon NOW and mail with your remittance, check or money order will do. Postage stamps accepted in small denominations if more convenient.



## Mail Coupon TODAY!

TELEVISION NEWS 100 Park Place, New York, N. Y. TN-4

As per your special offer, I enclose \$3.00, for which you are to enter my subscription to TELEVISION NEWS for one year and to RADIO-CRAFT for the next eight months.

Name .....

Address .....

City..... State.....

## The "Find-All" Television Receiver

By H. G. CISIN, M.E.  
(Continued from page 266)

- 1—Acratest 45-type Power Transformer (Television Model) (71).
  - 1—Acratest Double Filter Choke (two 30 Henry—80 mil. Chokes in Single Case) (69, 70).
  - 1—Roll Corwico Braidite Hook-up Wire, Solid Core.
  - 5—Five-Prong Wafer-type Sockets (5, 16, 29, 38, 49).
  - 3—Four-Prong Wafer-type Sockets (61, 72, 74).
  - 1—Amperite Self-Adjusting Line Voltage Regulator, type 8A-5 (72).
  - 4—Binding Posts (1, 2) and (62, 63).
  - 3—Tube Shields.
  - 5—124 Arcturus Screen-Grid Tubes (5, 16, 29, 38, 49).
  - 1—145 Arcturus Power Output Tube (61).
  - 1—180 Arcturus Rectifier Tube (74).
  - 1—Weston Milliammeter, 0-50 ma. type 301 (63A).
  - 1—Aluminum Chassis, 12 gauge, 12" x 15" x 3 1/2" high.
  - 2—Vernier Dials.
- (NOTE—Numbers in Parentheses refer to Corresponding Numbers Used to Mark Parts on Diagrams.)

### Radiovisor Parts Required

- 1—Jenkins Radiovisor Kit Assembly, type RK.
- 1—Low Internal Capacity Neon Lamp, type 601.
- 1—Lens Assembly, type RK-11.
- 1—Jenkins Self-Synchronizing Motor, type 502, with necessary amplifier Kit, type SK-30 (optional).

## The Thrill of a Televised Derby

(Continued from page 281)

parade of the horses and jockeys was witnessed by all present, while now and again a man or a woman would walk across the foreground and present a transient close-up.

### "The Winner" as Seen by Television

A short wait then occurred until we heard the B.B.C. announcer say the horses were rounding Tattenham Corner. Very soon after this the first three horses (not individually recognizable, of course, to be able to say which was which) flashed by the winning post, with the rest of the field following quite close on the leader's heels.

Horses and riders were there quite definitely, although the event portrayed before our critical eyes took place about fifteen miles away. The results proved conclusively that, even within the present limitations of the apparatus, television can be taken out of the studio and applied to outdoor topical events; and also that the need for artificial light and the restrictions of the studio can be dispensed with. The event can justifiably be termed a historic achievement and furthermore the Baird Company had, in effect, fulfilled a promise made years ago that it would some day be possible to see the Derby by television.—*Amateur Wireless, London.*

## Practical Operation of a Complete Television System

By ALLEN B. DU MONT  
(Continued from page 286)

### Receiving Programs

To receive the radiovision programs, we have developed several models of radiovisors, and also several models of television receivers. Without going to details, it may be stated in a general way that the receiving problem is practically the reverse of the transmitting problem. The modulated radio wave is received on a radio receiver of a sensitivity of about 10 microvolts per meter, and capable of passing frequencies of from 15 to 100,000 cycles with fairly flat characteristics. In this regard, we have developed an inexpensive receiver that can be assembled by the average experimenter. It is of the tuned R.F.

type, with a resistance-coupled audio amplifier including a power tube, and also a self-containing power pack for A.C. operation.

Really good half-tone pictures may be obtained with this receiver when employed in conjunction with one of the several models of radiovisors which we are producing. We have also developed a radiovision receiver of the superheterodyne type which has somewhat better characteristics, but is considerably more expensive to produce.

It might be interesting to note at this point that the proper receiver has been a minor problem. At no time have we been unable to duplicate the results obtained in the studio.

## Resistors for the Television Receiver

(Continued from page 306)

### Resistors In the Set Proper

As the illustration, Fig. 1, shows, the television receiver is full of resistors of all kinds and types. This is mainly because resistance-coupled

amplification is employed. Resistance coupling is used in all television receivers because of the wide range of frequencies encountered. In ordinary speech and music broadcast reception

Please mention TELEVISION NEWS when writing to advertisers

we only have a range of approximately 50 to 5000 cycles to amplify, and iron core transformers can be made to operate uniformly over this range.

In the television receiver, frequencies up to about 40,000 cycles must be amplified uniformly, and the resistance-coupled amplifier is the only type that will give flat frequency response characteristics over this wide range.

The variable resistor, 8, Fig. 1, is a volume control. In this particular circuit the clarostat graphite element volume control No. P5-50B, having a resistance of 50,000 ohms is employed.

The "C" bias resistors, 7, 18, 37 and 47 are each of 1,000 ohms and for this purpose the clarostat flexible wire resistors are recommended.

For the screen grid circuit resistors, 9, 19, 28A, 32, 39, 42, 50 and 53, 50,000 ohm pigtail type units are employed.

Resistors 31, 43 and 55 are plate circuit filtering resistors. They are each of 25,000 ohms resistance, of the pigtail type capable of carrying the full plate current of the tubes.

The grid leak resistor 27 for the space charge detector has a resistance of 50,000 ohms. This may be of the usual grid leak type.

The plate circuit filtering resistors in the R.F. amplifier, 12 and 22, each have a value of 75,000 ohms. These may be of the pigtail construction.

For the image frequency amplifier grid leaks, 35, 45 and 57, 250,000 ohm units are employed, of the pigtail type.

The power tube "C" bias resistor, 60, should be of greater current-carrying capacity than the other bias resistors. This one has a resistance of 1,500 ohms.

The voltage divider, 64, is also very important. This should be of sufficient wattage rating so as not to become too hot with a possibility of burning out. A 20,000 ohm resistor is employed with a tap at 10,000 ohms.

Sometimes it is more convenient to employ a center tapped resistor across the filament circuit, than to make a connection to a center tapped transformer winding. The clarostat fixed center tapped resistor shown at 59, is provided for this purpose. It has a resistance of 20 ohms.

### Columbia Is Telecasting!

(Continued from page 253)

visual broadcasting, and is especially noteworthy for its compactness.

The station, W2XAB, is licensed experimentally by the Federal Radio Commission. It will operate in the channel from 2,750 to 2,850 kilocycles with 500 watts power. Sixty-line scanning at twenty frames per second (1200 revs. per minute), are the picture specifications.

The image broadcast will have a sound outlets on W2XE, (6120 K.C. or 49.02 meters), Columbia S-W station.

A daily schedule (including Sunday) of from 2 to 6 P.M. and from 8 to 11 P.M. will be maintained.

# LUGGAGE

## BUY AT WHOLESALE PRICES

Save 40% by Dealing Directly with One of America's Leading Luggage Manufacturers.

### "GLADSTONE" OF GENUINE TOP GRAIN COWHIDE LEATHER, \$12.50

The ever popular Gladstone, with solid brass locks and catches. Short leather outside straps. Lined with very fine quality tan twill cloth. Comes in choice of Brown or Black Shark Grain Genuine Cowhide. F.O.B.—New York.

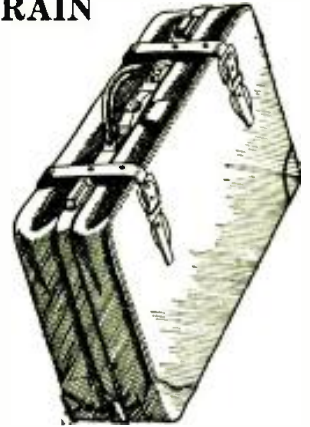

Size 22 and 24 inches (choice)

### OVERNIGHT CASE \$2.95

#### DANDY PORTABLE RADIO AND INSTRUMENT CASE



Built over solid wood frame, covered with durable Fabricoid that wears better than cheap leather. Lined with good quality cloth. Has neat shirred pockets in lid and body. Size 16 inches. Strong leather handle; 2 locks; colors, Brown or Black.

Special "Overnight" Case: Silk-lined, beveled mirror in cover. Brass locks, leather handle, covered with Dupont. F.O.B. 12x14 in. \$2.95

Same case, Genuine Cowhide.....\$4.95

### FOR GOLFERS, SPORTSMEN AND TRAVELERS

#### Made of Solid Hand-Boarded Cowhide

Roll Golf and Sports Bag, with Zipper. Exceptional value. Genuine Hand-Boarded Cowhide in Russet and Brown. Fitted with Lock. Size: 18-inch, \$10.50 Size: 20-inch, \$11.00

(F.O.B.—New York)

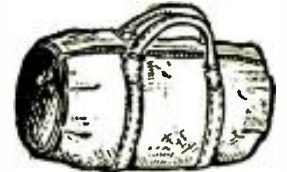

### HANDSOME "CAMP" TRUNK and LOCKER

Hand-some Camp Trunk and Locker, made of three-ply veneer basswood, covered and bound with fibre, strong draw bolts and good snap lock, three hinges. This trunk has the special feature of "dust-proof" tongue and groove steel molding around the opening edges of trunk.

Interior of trunk has one tray with three compartments. Color: Maroon Body, Tan Binding.

Size: 32-inch, \$10.50 Size: 36-inch, \$11.50

F.O.B.—New York.

### SOLID 5-OZ. LEATHER BRIEF CASE

Wide cowhide straps all around. The top of the gusset is folded to give more strength. Whole case double stitched and riveted at the corners. Flap reinforced with leather 1½" wide. Size 16x11 inches. Colors: brown, black or mahogany.

\$3.50—Model D—2 pockets.

\$4.00—Model E—3 pockets.

\$4.50—Model F—4 pockets.

\$5.00—Model G—5 pockets.

All prices F.O.B., New York



Mail Orders only—no C.O.D.'s—All Prices are F.O.B. New York. Satisfaction Guaranteed or money cheerfully refunded. Send Money Order or Check. Be sure to get our prices on all Luggage and Trunks.

## "C and S" Supply Co.

221 FOURTH AVE.,

NEW YORK CITY, N. Y.

Please mention TELEVISION NEWS when writing to advertisers

**TELEVISION TIME-TABLE**

Visual Broadcasting Stations, Alphabetically by Names of Stations

Furnished by U. S. Dept. of Commerce, Radio Division, Washington, D. C.

Location of Transmitter	Lines per Frame	Call Signal	Frequency in kilocycles (meters in parentheses)	Power (watts in antenna)	Licensee and Address
Illinois: Chicago	48	W9XAA	2,000 (150) to 2,100 (142.9), 2,750 (109.1) to 2,850 (105.3)	1,000	Chicago Federation of Labor.
" "	45	W9XAO	2,000 (150) to 2,100 (142.9)	500	Western Television Corp., 6312 Bway, Chicago Daily News
" "	15	W9XAP	2,100 (142.9) to 2,200 (136.4)	2,500	Great Lakes Broadcasting Co., 72 W. Adams St., Chicago.
Downers Grove	24	W9XR	2,850 (105.3) to 2,950 (101.7)	5,000	
Indiana: West Lafayette	—	W9XG	2,750 (109.1) to 2,850 (105.3)	1,500	Purdue University, 400 Northwestern Ave.
Iowa: Iowa City	—	W9XAZ	2,000 (150) to 2,100 (142.9)	500	State University of Iowa
Maryland: Silver Springs	60	W3XK	2,000 (150) to 2,100 (142.9)	5,000	Jenkins Laboratories, 1519 Connecticut Ave., Washington, D. C.
Massachusetts: Boston	60	W1XAV	2,850 (105.3) to 2,950 (101.7)	1,000	Shortwave and Television Laboratory (Inc.)
New Jersey: Allwood	—	W2XCP	2,000 (150) to 2,100 (142.9), 2,850 (105.3) to 2,950 (101.7)	2,000	Freed-Eisemann Radio Corp., Junius St. & Liberty Ave., New York, N. Y.
Camden	60	W3XAD	2,100 (142.9) to 2,200 (136.4), 43,000 (6.97) to 46,000 (6.52), 48,500 (6.18) to 50,300 (5.96), 60,000 (5) to 80,000 (3.75)	500	R. C. A. Victor Company (Inc.)
Passaic	60	W2XCD	2,000 (150) to 2,100 (142.9)	5,000	De Forest Radio Co.
New York: Beacon	48	W2XBU	2,000 (150) to 2,100 (142.9)	100	Harold E. Smith, United Research Corp., 39 Van Pelt Ave.
Long Island City	—	W2XB0	2,750 (109.1) to 2,850 (105.3)	500	Radio Pictures, Inc., 3101 Northern Blvd.
" " "	48	W2XR	2,100 (142.9) to 2,200 (136.4), 2,850 (105.3) to 2,950 (101.69)	500	Atlantic Broadcasting Corp., 485 Madison Ave.
New York	60	W2XAB	2,750 (109.1) to 2,850 (105.3)	500	National Broadcasting Co. (Inc.), 711 Fifth Ave.
" "	60	W2XBS	2,100 (142.9) to 2,200 (136.4)	5,000	Jenkins Television Corp., 316 Claremont Ave.
" "	60	W2XCR	2,000 (150) to 2,100 (142.9)	5,000	Robert F. Gowen, General Electric Co.
Ossining	—	W2XX	2,000 (150) to 2,100 (142.9)	100	
Schenectady	—	W2XCW	2,100 (142.9) to 2,200 (136.4)	20,000	
Pennsylvania: East Pittsburgh	60	W8XAV	2,100 (142.9) to 2,200 (136.4)	20,000	Westinghouse Electric & Mfg. Co.
" "	60	W8XT	660 (455)	25,000	Westinghouse Electric & Mfg. Co.
Wisconsin: Milwaukee	—	W9XD	43,000 (6.97) to 44,000 (6.81)	500	The Journal Co. (Milwaukee Journal).
PORTABLE					
Massachusetts: Boston	60	W1XG	43,000 (6.977) to 46,000 (6.522), 48,500 (6.186) to 50,300 (5.964), 60,000 (5), 80,000 (3.75)	30	Shortwave & Television Corp., 70 Brookline Ave.
New Jersey: Passaic	60	W2XAP	2,000 (150) to 2,100 (142.9)	250	Jenkins Television Corp.
Bound Brook	60	W3XAK	2,100 (142.9) to 2,200 (136.4)	5,000	National Broadcasting Co., Inc.
New York State: —	—	W2XBT	43,000 (6.977) to 46,000 (6.522), 48,500 (6.186) to 50,300 (5.964), 60,000 (5), 80,000 (3.75)	750	National Broadcasting Co., Inc.

**Time on the Air:** The daily newspapers in the larger cities—Chicago, New York and Boston, for example—carry television programs and time schedules.

Experimental television stations, such as those operated by the N. B. C., Westinghouse, General Electric Co., etc., are on the air practically every day, testing, and can be picked up.

The Jenkins stations' time schedules are as follows:

W2XCR—N. Y. City, 3 to 5 and 6 to 8 P.M. daily; 6 to 8 P.M. Sunday. Voice transmitted over WGBS, on 381.4 meters or 780 k.c. (Time is Daylight Saving.)

W3XK—Washington, D. C., 7 to 9 P.M. and 10:30 to 11:30 P.M. daily (D.S.T.). 60 holes.

W2XAP—Passaic (Portable transmitter), 60 line, 20 frames per second "standard"—Time irregular—Experimental.

W2XCD—Passaic (De Forest Radio Corp.), 9 to 10 P.M. daily. Sound accompaniment transmitted on 1,601 k.c.

Columbia Broadcasting System (W2XAB) went on daily transmission schedule July 21st, 60 holes, 20 frames (revs.) per second (or 1,200 r.p.m.), Voice transmitted on 6,120 k.c. (49.02 meters) W2XE.

Short Wave and Television Corp., Boston, Mass., transmits image (W1XAV) daily, 60 holes, 20 frames per second, and voice accompaniment on 1601 k.c. or 187 meters (W1XAU).

Note that the general standard now is 60 holes (or lines) and 20 frames per second, or 1,200 revs. per minute for the motor and its associated scanning disc at the receiver. Also, if you "look in" at a New York image in New Jersey, or vice versa, you need a phonic wheel synchronizing motor on the same shaft with your main driving motor, in order to keep the image from drifting, as the A.C. systems in the two states are not synchronized.

It is understood, of course, that two receiving tuners or sets are required to pick up voice and image, such as from W2XCR and WGBS, one set tuned to 147.5 meters for reception of the image and one set tuned to WGBS or 381.4 meters to pick up the voice.

Daily image programs are broadcast by the Boston station W1XAV, and also by the Chicago stations W9XAA, W9XAO and W9XAP.

**Seeing Is Believing**

(Continued from page 293)

**Enlarges Image With Crater Tube**

Editor TELEVISION NEWS:

I have been obtaining some very excellent results with my experimental television receiver and scanner, utilizing a neon crater tube. I operate this tube from a '50 amplifier and obtain a picture about sixteen inches square, projecting the image on a piece of cardboard, or even on the wall in some cases.

Speaking of amplifiers, I have tried many kinds but I finally settled down to a three stage, resistance-coupled affair, and I have tried Daven as well as Allen-Bradley amplifiers with good results. I have had some fairly good results with a magnetic brake system similar to that described in the last issue of TELEVISION NEWS and in some cases I have been able to hold the image steady for several minutes at a time, by placing a finger against the television scanner disc.

I also tried out a simple braking system by fastening a piece of leather so as to lap around the shaft, half-way; one end of this leather brake band was fastened permanently to a piece of wood, and to the other end of the brake band I secure a piece of wire, which in turn was fastened to a pivoted lever, one end of which carried a button similar to a telegraph key. By alternately pressing and releasing this lever I obtained very good control of the scanner disc speed.

"Visualists" who live in a different locality than that served by the electric light distribution system, furnishing power to the transmitter stations, experience trouble from a drifting of the image, when using a synchronous motor. Here, sincerely hoping that TELEVISION NEWS will wage some kind of a campaign, in order to make the electric power companies get together and "synchronize" their A.C. systems. I know it can be done and am sure that there is only the matter of a little more time, before it will be done. Electric clocks maintain the accurate time they do, not because the A.C. system frequency is so constant, but because of the fact that the plus and minus changes occurring in a given time, say an hour or a day, "cancel out," with the result that the clock at the end of such a given time, keeps accurate time. In other words if the clock loses 1/10th of a second in one hour and gains 1/10 of a second in the next hour, at the end of the two hours, it would indicate the correct time.

Sad to relate however, such fluctuations are "too rich for the blood" of a television receiver system, as a little reflection will show, there being 1200 changes of light per second in modern television systems.

When it is remembered that a scanning disc with its 60 holes, for example, whirling around at 20 times per second, results in 1200 light pulses per second; and that these must be "absolutely in step" with the 1200 light changes taking place at the television transmitter station; it will be seen that there just cannot be any fluctuation in the A.C. supplying the scanner at the television receiver.

The way it is now there may be and frequently are slight fluctuations in the frequency, for example in the A.C. distributing system supplying the town I live in; also there are slight frequency fluctuations in the A.C. system in the different cities where the television transmitters are located and the systems are never in absolute synchronism at all times.

E. A. Ramsey, N. J.

(This is a big problem "E.I" we will admit and we shall do the very best we can to help remedy it.—Editor.)

**Mr. TELEVISION FAN!**

TELL US HOW YOU

**Hold the Image Steady?**

Articles with Photos and Diagrams desired; if published, they will be paid for.

# STOP SHOPPING!!

HERE'S a NEW plan, which saves you money. Stop shopping—the lowest prices are right on this page. Yes, lower than in our own catalog. Why? Because no house can get out a new catalog every month, but by advertising in this magazine we can bring

you the latest and lowest prices up to the time this ad is printed. We watch our competitors and do not allow anyone to undersell us. We meet ANY price on NEW merchandise. Order direct from this page and save money. 100% satisfaction on every transaction.

## NEW! NEW!

Several months ago we sent out a questionnaire to 2,000 radio service men and asked them what their ideas were on a radio service kit. 865 answered us, and their ideas are now embodied in the Official Radio Service Kit which we herewith present to you.

This kit is a marvel in compactness, a marvel in price, a marvel in time saving. For the first time you are offered a comprehensive kit that contains EVERYTHING that the service man requires in making calls.

### ARE YOU A 50 PER CENT SERVICE MAN?

Too often so-called service men go on a job with an analyzer and a pair of pliers. Nine times out of ten they have to run back to the shop to get tools, and thus their usefulness is cut down, as a rule, 50% and over. Why not take along, on every job, a business-looking like service kit that looks just as business-like as your analyzer?

When you call upon a prospect and you arrive with this fine-looking kit, your prospect knows that you mean business. It gives you a professional appearance that every service man requires more than anything else today.

### AND YOU CAN COMMAND MORE MONEY ON YOUR SERVICE CALLS WITH THIS KIT

because the prospect will look upon you as a professional, and not as a tinkerer.

When you visit a medical specialist today, you are impressed by his instruments, for which you pay. An ordinary doctor commands no such fees. It should be clear to you that if you are a professional, you can get professional prices today too. That is why this marvelous kit will pay for itself inside of three months or less.

Herewith are the Official Radio Service Kit specifications: Size, small and compact, not larger than a good analyzer; 17 in. long, 6 3/4 in. wide and 10 in. high.

Construction, wood veneer throughout, entirely covered with black leatherette, all nickel trimmings, giving outfit a beautiful professional appearance.

There are two trays which lift out. Top tray contains the following:

- 1 Pen Flashlight, complete with magnifying dentist's mirror (to look underneath chassis, etc.).
- 1 Automatic alcohol blow torch.
- 1 Box containing 300 assorted screws, nuts, washers, lugs, etc.
- 1 Nickel bicycle wrench.
- 1 Tap holder with one 6/32 tap and one 8/32 tap.
- 1 Set of Test prods, with 6 ft. cord.
- 1 Telephone type pliers.
- 1 Diagonal pliers.
- 1 Insulated (5,000 volt insulated handle) heavy pliers.
- 1 Electrician's knife.
- 1 Set of 8 drill points.
- 10 Ft. of Phosphor bronze drum dial cable.
- 1 Neutralizing socket.
- 1 Pack extra size pipe cleaners (to clean condensers).
- 3 Small screw drivers.

## Official Radio Service Kit

**\$15.75**



Both felt lined trays are built to fit the tools and contents of kit. Everything ALWAYS in Place. No hunting for this or that item. Neat. Efficient.

## NEW! NEW! IMPORTANT!

There is sufficient room in the bottom of the kit to place the Official Radio Service Manual, as well as other data sheets (but at the price quoted Manual is not included).

Both trays, as well as inside cover, are lined with blue felt, giving kit a beautiful appearance.

Nothing similar has ever been offered before. Only by having the various materials in tremendous quantities are we enabled to sell this kit at such an extremely low price.

If you were to buy all of the articles separately, in the open market, you would have to pay between \$30.00 and \$35.00 for them.

Due to the present depression, we are enabled to buy quantities of these materials at exceedingly low prices. For that reason, our production cost is exceedingly low, but there is no question that this price will have to be increased later.

Size, 17 in. long, 6 3/4 in. wide and 10 in. high; net weight, 16 lbs.; shipping weight, 18 lbs.

No. 1000—Official Radio Service Kit—Your price..... **\$15.75**

### CARRYING CASE

We are prepared to furnish you with the Official Radio Service Case only, without contents, as described above, just the case and the two empty trays, size 17 in. long, 6 3/4 in. wide and 10 in. high.

This case is made entirely of light veneered wood, nickel trimmings, covered entirely with leatherette, inside of case covered in blue felt.

Net weight, 4 lbs. Shipping weight, 5 lbs.



No. 1001—Official Radio Service Carrying Case only, your price **\$4.85**

View of kit, closed.

### RADIO CARRYING CASES

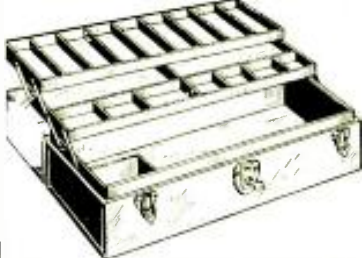

The cases here shown are a new development. They are made in metal throughout with baked olive green enamel finish. These cases are beautifully and strongly made, and will give you a professional appearance. Lock and side locks are of burnished brass.

The smaller illustration shows dimensions and closed view of the cases. As you open the cover, two trays automatically fold out in position, as shown. As you lift the cover back, the trays fold automatically into the case. The trays are provided with a number of compartments for tools and all other radio appliances that you may wish to carry. The large box accommodates about eight radio tubes in the bottom compartment. The smaller case accommodates about four tubes.

Cases are strong and rugged, and when closed, nothing can spill. They are marvels of ingenuity, and will pay for themselves many times over.



Large size measures 21 1/2 in. long, 7 1/2 in. high and 7 in. wide. Net weight 8 lbs. Shipping weight 10 lbs. Last price \$8.50. No. 1002—Carrying Case, your price **\$4.75**

### SMALL CARRYING CASE

This case is in all respects the same as the one described above, except that the dimensions are less, otherwise the same in all respects.

Size 12 1/2 in. long, 7 1/2 in. high and 7 in. wide. Net weight, 5 lbs.; shipping weight, 6 lbs. Last price, \$6.50. No. 1003—Carrying Case—Your Price **\$3.45**

## NEW! NEW!!

### Superheterodyne S-W Converter



At last a short-wave converter that converts any broadcast set into a superheterodyne short-wave receiver. Employs three 227 tubes and covers from 20 to 115 meters. No plug-in coils! Coil switch is used to cover all wavelengths. Single dial control, no body capacity, no squeals. This converter has built-in filament transformer to heat the three 227's.

All you need to obtain from your receiver is a positive B voltage anywhere from 45 to 180 volts. Voltage is not critical; no modulation of the receiver. So simple a child can operate it. Size 7 x 10 x 3 inches. Shipping weight, 8 lbs. List Price \$25.00.

No. 1614—Super Converter (less tubes). YOUR PRICE..... **\$14.69**

### World-Wide Short-Wave Set NOT A CONVERTER

## NEW



A perfect radio short-wave receiver for use between 17 and 81 meters. To put into operation, connect antenna, ground, 45-volt "B," and 6-volt "A," batteries, and headphones to the posts provided, plug in a type 61A tube, and tune in! An ingenious circuit makes possible a 4-coil single-winding plug-in design. This little instrument has the same sensitivity as many big, shielded short-wave receivers costing ten times as much. A power amplifier may be added for any degree of volume. Complete with 4 plug-in coils. Has fine vernier dial for precision tuning. Never has a first class short-wave set sold for so little money. This short-wave set measures 5 1/2 x 7 x 1 in. high, over all. Ship. weight, 3 lbs. List price, \$12.50.

No. 1666—World-Wide S.-W. Set. **\$6.25**

## New 36 page Summer Edition No. 23



75 New Hook-Ups, etc. 350 Illustrations.

The new Summer Edition of our greatly enlarged RADIO SERVICE TREATISE has just come off the press. If you liked the Winter Issue, you will like this one a hundred-fold. It contains some 75 new hook-ups, circuit diagrams; and some 350 illustrations. POSITIVELY THE GREATEST BOOK EVER PUT OUT BY ANYONE. Among the new matters listed are:

VACUUM TUBE TREATISE, with many illustrations; full page Vacuum Tube Average Characteristics Chart; How to Take Care of Your Tubes; How to Connect Phonograph Pick-ups; Improving the Tone Quality of Old Sets; Connecting Additional Loud Speakers; all fully illustrated with diagrams.

Other articles: Modernizing Old Radio Sets; How to Convert Battery to Power Sets; Selection of Tubes; Push-Pull Amplifiers; Replacing Audio Transformers; Phono Attachments; How to Choose Power Transformers; Voltage Dividers; Wattage of Power Transformers; Selecting and Installing Replacement Parts in Radio Sets; Filter Condensers; Repairing Eliminators.

WRITE TODAY. Enclose 2 cents for postage. Treatise sent by return mail.

### THORDARSON

### "245" Power Transformer

A Miniature Power Plant — Supplies All ABC Voltages — 80 Watts



In addition to supplying a full 250 volts to the plates and 50 volts to the grids of two type 45 tubes in push-pull, this transformer may be used to light the filaments of seven or eight 2.5-volt filament tubes; and by connecting in series two of the three 2.5-volt filament secondaries it is possible to light 5-volt filaments too. Five secondaries: S1—5 V., 2 Amp.; S2—340 V. Cent. T.; S3—2 1/2 V., 3 Amp. Cent. T.; S4—2 1/2 V., 10 1/2 Amp.; S5—2 1/2 V., 3 Amp. Cent. T. Just the power transformer for building up a high-grade public address amplifier to use a screen-grid A.F. amplifier to boost the output of a microphone or phonograph pick-up; following this with two stages of push-pull amplification consisting of two '27's in the first stage and two '45's in the second. Bottom of transformer has bakelite panel on which are mounted all taps. It outperforms ANY similar transformer. Many Service Men keep this model transformer on hand for emergency replacements in hundreds of makes of radio sets. For 110-120 volts, 50-60 cycles. Size: 5 in. high x 4 x 3 1/2 in. Shipping weight, 8 lbs. List Price, \$15.00.

No. 1450—Thordarson Power Transformer. YOUR PRICE..... **\$3.84**

### High-Voltage Condenser Units

We guarantee these condensers unconditionally. They are ideal for general replacement purposes and can be installed in any new power-pack. All condensers are furnished with 8-inch lengths of sinned "push-back" wire.

600 VOLTS			800 VOLTS		
Cat. No.	Mfd. Capac.	Your Price	Cat. No.	Mfd. Capac.	Your Price
1702	1/2	\$0.25	1706	1	\$0.40
1703	1	.30	1707	2	.70
1704	2	.40	1708	4	1.05
1705	4	.60			

WE ARE A WHOLESALE HOUSE AND CANNOT ACCEPT ORDERS FOR LESS THAN \$3.00.

If C. O. D. shipment is desired, please remit 20% remittance, which must accompany all orders.

If full cash accompanies order, deduct 2% discount. Send money order—certified check—U. S. stamps.

**Radio Trading Co.**  
25 West Broadway  
New York, N. Y.

ORDER FROM THIS PAGE. You will find special prices from time to time in this magazine. Get our big FREE catalog for the greatest Radio Bargains.

Should you wish goods shipped by parcel post, be sure to include sufficient extra remittance for same. Any excess will be refunded.

# WORLD'S BEST RADIO BOOKS



**ORDER DIRECT FROM THIS PAGE**

WE herewith present to the readers of TELEVISION NEWS the most complete collection of recent important radio books. We have, after an exhaustive study, selected these volumes because they represent the foremost radio books of their kind in print today. There is such a great variety that we are sure it will satisfy any taste as well as any requirement that the student of radio might have.

We publish no catalogue and ask you to be kind enough to order direct from this page. Prompt shipments will be made to you direct from the publishers. We merely act as a clearing house for a number of radio book publishers and OUR PRICES ARE AS LOW OR LOWER THAN WILL BE FOUND ANYWHERE. Prompt shipments will be made.

Remit by money order or certified check. If you send cash, be sure to register it. If you wish to get any other radio book, please write us.

**EXPERIMENTAL RADIO**, by R. R. Ramsey, Professor of Physics, Indiana University. Cloth covers, size 7 1/2 x 5 1/4", 256 pages, 168 illustrations. Price, postpaid ..... **\$2.75**

This book by Professor Ramsey is written in the nature of an experimental radio course and contains 128 experiments, illustrated and described in a clear and interesting style. The experiments cover such valuable subjects as: A test on a loud speaker; the impedance of coils; construction of a filter, screen grid tube; beat note audio oscillator; etc.

**PRINCIPLES OF RADIO COMMUNICATION**, by J. H. Morecroft, Prof. of Electrical Engineering, Columbia University. Cloth covers, size 9 1/2 x 6", 388 pages. Profusely illustrated. Price ..... **\$7.50**

A radio classic, indeed, is Professor Morecroft's very complete text-book which covers such important radio phenomena as: the action in condensers; self and mutual induction in a circuit; phase and phase difference; effect of condensers and coils on wave shape; resonance frequency of coupled circuits; skin effect in coils; antenna resistance; transformers; vacuum tubes; radio frequency alternators; modulation and circuits; amplifiers and filters.

**RADIO TRAFFIC MANUAL AND OPERATING REGULATIONS**, by R. L. Duncan and C. E. Drew. Flexible covers, size 9 1/2 x 6", 186 pages. Price **\$2.00**

This valuable handbook starts off with instructions on how to learn the code in considerable detail, with a list of abbreviations. Then comes operating rules and regulations of the Radiophone Corporation of America with operators' report forms; followed by the rules of the International Radiograph Convention; the United States Radio Act of 1927; the Ship Act of 1912; etc.

**PHOTOCELLS AND THEIR APPLICATION**, by V. K. Zworykin, E. F. Ph.D., and E. D. Wienn, Ph.D. Cloth covers, size 5 1/2 x 8", 210 pages, 97 illustrations. Price ..... **\$2.50**

Photo-cells today occupy a very important place in radio and talking pictures, as well as other branches of applied science, and these two experts have provided the very latest information as to the action taking place in various types of photo-cells. The theory on which these different cells operate, including color sensitivity, together with amplifier and scanning discs used in picture as well as television transmission, etc.

**PRINCIPLES OF RADIO**, by Keith Henney, M.A. Cloth covers, size 8 1/2 x 5 1/4", 478 pages, 306 illustrations. Price **\$3.50**

The author is well known in radio and he has here provided a very complete and clearly written discussion of radio circuits and apparatus, including such important topics as: condensers; transformers; determination of inductance;

vacuum tube action, including Screen Grid and Pentode; wave meters, their calibration and use; modulation; amplifiers; long wave receivers; and different types of rectifiers.

**HOW TO PASS U. S. GOVERNMENT RADIO LICENSE EXAMINATIONS**, by R. L. Duncan and C. E. Drew. Flexible covers, size 9 1/2 x 7", 170 pages, 92 illustrations, appendix. Price ..... **\$2.00**

The authors are thoroughly conversant with their subject and all of the most important information including hook-ups; types of antennae and receivers with wiring diagrams of both small and large receivers and transmitters of commercial type, including ship sets are given.

**RADIO RECEIVING TUBES**, by Moyer and Wostrel. Cloth covers, size 7 1/2 x 5 1/4", 298 pages, 181 illustrations. Price ..... **\$2.50**

No radio student or operator can do without this authoritative book on the radio vacuum tube. The various chapters include construction of vacuum tubes; electrical fundamentals; elementary action taking place in the vacuum tube, with graphs; reactivation of tubes; testing of tubes including determination of amplification factor; plate resistance; grid resistance, etc.

**PRACTICAL RADIO—INCLUDING THE TESTING OF RADIO RECEIVING SETS**, by James A. Moyer, S.B., A.M., and John F. Wostrel, Cloth covers, size 8 1/2 x 5 1/4", 378 pages, 223 illustrations. Price ..... **\$2.50**

Everyone will find this volume of the utmost practical value as the authors have explained in text and diagrams, for the practically-minded student, such interesting subjects as: telephone receivers and crystal sets; various types of aerials; current sources for vacuum tubes; audio and radio frequency amplification with hookups; loud speakers and how they work; various radio receiving sets with diagrams and just how they work.

**PRACTICAL RADIO CONSTRUCTION AND REPAIRING**, by J. A. Moyer, S.B., A.M., and J. F. Wostrel. Cloth covers, size 8 1/2 x 5 1/4", 354 pages, 163 illustrations. Price... **\$2.50**

This handbook is one that every radio set tester and general student will want to read carefully. These experts have given a very complete description of instruments used to test and repair modern radio sets, together with complete diagrams of many modern receiving sets, with explanations on how to test the radio and audio frequency stages for faults.

**ELEMENTS OF RADIO COMMUNICATION**, by Professor John H. Morecroft. Cloth covers, size 9 1/2 x 6", 270 pages, 170 illustrations. Price... **\$3.00**

Professor Morecroft explains in an authoritative and clear manner such important radio phenomena as current flow in circuits containing capacity and inductance; propagation of radio waves; vacuum tubes as detectors and amplifiers; fading of radio waves and its causes; neutralization; superheterodynes for short waves, etc.; audio frequency amplifiers; how filters work, etc.

**RADIO TELEGRAPHY AND TELEPHONY**, by R. L. Duncan and C. E. Drew. Cloth covers, size 9 1/2 x 6", 950 pages, 468 illustrations. Price **\$7.50**

This 950 page book forms indeed a most complete treatise on radio facts. The authors treat thoroughly the magnetic circuit; Ohm's law; transformers and induction; motor generators and starters; storage batteries; alternating currents; capacity and inductance formulae. Vacuum tubes as detectors and amplifiers; oscillographs; radio compass; wavelength measurements and short wave receivers.

**RADIO SERVICE MAN'S HANDBOOK WITH ADDENDA DATA SHEETS**, Flexible covers, size 9 1/2 x 12", 200 pages, 200 illustrations. Price, prepaid ..... **\$1.95**

This remarkable book contains several hundred illustrations with wiring diagrams and charts covering every conceivable subject, including radio sets, tubes, etc. The book is strictly up-to-date and contains the newest practical information which every radio man absolutely must have.

**OFFICIAL RADIO SERVICE MANUAL**, by Hugo Gernsback and Clyde Fitch. Flexible covers, size 9 1/2 x 12", over 1,000 illustrations, 352 pages. Price, prepaid ..... **\$2.98**

Commercial wiring diagrams for all the regularly manufactured receiving sets are included in this manual and no radio service man or student who builds and repairs radio sets can be without this tremendously useful compilation of circuits and their descriptions. This book is worth \$100.00 to anyone who has a use for it. The Manual is indexed so that any commercial receiving circuit can be found instantly. One of the most valuable radio books ever published.

**Howtoorder**  
We cannot make C.O.D. shipments. Our prices are net, as shown on this page. You will note that some of the books include postage. Those that do not will be shipped by express collect if you do not wish to include a sufficient amount of postage.

**FUNDAMENTALS OF RADIO**, by R. R. Ramsey, Professor of Physics, Indiana University. Cloth covers, size 9 1/2 x 6", 372 pages, illustrated. Price, prepaid ..... **\$3.50**

Dr. Ramsey gives us a very refreshing treatment of the fundamentals of radio, including battery and dynamo action; alternating currents; inductance; vacuum tube constants; aerials of different kinds and how they operate; radio frequency instruments and apparatus; audio amplification and receivers in general.

**RADIO TROUBLE SHOOTING**, by Eunor R. Haan, E.E. Flexible covers, size 6 x 9", 323 pages, 257 illustrations. Price ..... **\$3.00**

This is a well illustrated and intensely practical handbook for all radio service men and operators, as well as set builders and testers. Some of the practical problems illustrated and discussed are: interference and noise problems—how to locate and remedy them; antenna circuit troubles and their effect on radio; batteries, chargers and eliminators.

**DRAKE'S RADIO CYCLOPEDIA**, by H. F. Manly. Cloth covers, size 6 x 9", 1035 pages, profusely illustrated. Price ..... **\$6.00**

This massive encyclopedia covers radio apparatus—its operation and maintenance, the various subjects being alphabetically arranged. There are 1735 subjects in alphabetical order ranging from A-battery to zero-beat. This volume contains 1110 illustrations, diagrams, etc. There are 411 illustrations and articles on the building and designing of radio sets, alone; 110 articles with 383 illustrations on the methods of repair, service and adjustment of radio sets.

**S. GERNSBACK'S RADIO ENCYCLOPEDIA**, by S. Gernsback. Stiff leatherette covers, size 9 1/2 x 12", 168 pages, profusely illustrated. Price ..... **\$1.65**

Radio apparatus, inventors and terms are all illustrated and described in this remarkable book which required the efforts of several engineers in its compilation. The subjects are alphabetically arranged and the illustrations are especially fine and clear.

**TELEVISION TO-DAY AND TOMORROW**, by S. A. Moseley and H. J. B. Chapple. Cloth covers, size 8 1/2 x 5 1/4", 130 pages, profusely illustrated. Price, prepaid ..... **\$2.50**

This up-to-the-minute work on television describes in detail the apparatus used by Baird. The student will learn all about scanning discs; the best type of motor; reverse defects and how to overcome them; isochronism and synchronization; various ways of synchronizing the receiving discs; photocells and neon tubes; radio receivers for television signals; noctovision.

**SOUND PICTURES AND TROUBLE SHOOTER'S MANUAL**, by Cameron and Rider. Cloth covers, size 8 1/2 x 5 1/4", 1120 pages, profusely illus. Price ..... **\$7.50**

This useful volume will appeal to all radio as well as "talkie" trouble-shooters. The first chapters deal with fundamentals of electrical circuits, including Ohm's law, A.C. and D.C. circuits, rectifiers, amplifiers, mixers and faders; various types of loud speakers and how to arrange them; photocells; electric motors; various types of talkie projectors; also commercial amplifiers with diagrams are given.

**RIDING THE AIR WAVES, WITH ERIC PALMER, JR.**, by himself. Cloth covers, size 7 1/2 x 5 1/4", 328 pages. Price ..... **\$2.00**

Short wave fans cannot miss reading this highly entertaining and informative book which tells the story of youthful Mr. Palmer and his remarkable achievements in amateur radio. "Around the World with 5 Watts" and many other interesting subjects appear between the covers of this book.

**A POPULAR GUIDE TO RADIO** by B. Francis Dashiell. Cloth covers, size 5 1/2 x 8 1/4", 286 pages, profusely illustrated. Price, prepaid ..... **\$3.50**

The author starts off with an excellent section on electricity and magnetism; the use of radio aerials and grounds; the fundamental principles of radio; the electron tube and crystal rectifiers—how they work; the Principle of radio amplification; radio inductance coils and condensers; fundamental radio receiving circuits; electrical reproduction of sound; the atmosphere and radio phenomena, etc.

**RADIO VISION**, by C. Francis Jenkins. Cloth covers, size 9 1/2 x 6", 144 pages, profusely illustrated. Price, prepaid ..... **\$1.25**

A beautifully printed and interesting illustrated history of transmission of images by radio; particularly covering the apparatus and successful demonstrations of the Jenkins system. Other apparatus illustrated and discussed are the Braun tube receiver; the J.C.A. Photo-radio apparatus; the A. T. & T. Company system; and the Belin machine.

**RADIO MOVIES AND TELEVISION**, by C. Francis Jenkins. Cloth covers, size 9 1/2 x 6", 144 pages, profusely illustrated. Price, prepaid ..... **\$2.50**

An absorbing history, handsomely illustrated, of the Jenkins system of transmitting and receiving movies "via radio." One of the chapters gives constructional details and drawings for building your own Radiovisor or machine for making the radio movies visible in your home. Diagrams of amplifiers are given, with some other very valuable information.



# CONTINENTAL

ANNOUNCES A

# TELEVISION KIT



The above is a picture of a television set made up from a Continental television kit.

Our financial resources and staff of experienced television engineers will enable this corporation to become one of the foremost in the industry.

THE RESULT OF EXHAUSTIVE LABORATORY EXPERIMENTATION AND THE RESEARCHES OF THE FOREMOST TELEVISION ENGINEERS.

**CONTINENTAL  
TO COVER ENTIRE  
TELEVISION IN-  
DUSTRY.**

In addition to this most advanced television kit the Continental Television Corp. is prepared to enter every branch and phase of the television industry.

This organization will manufacture television apparatus for home and commercial purposes. It will also enter the broad field of broadcasting and communications.

*Television Kits  
Television Projectors  
Television Broadcasting  
Commercial Television  
Home Movies*

*Our Descriptive Circular Gives More Detailed Information. SEND FOR YOUR COPY.*

**CONTINENTAL TELEVISION CORP.**  
**NEWARK, NEW JERSEY**

NATIONAL DISTRIBUTORS  
**GOLD SEAL ELECTRICAL COMPANY**  
NEWARK, NEW JERSEY

00016MF



THE GUIDING SIGN OF

QUALITY IN RADIO PRODUCTS

use

# PILOT RADIO PARTS

in your television receiver and

SEE the difference in results!

You can't afford to waste money and effort on cheap parts when you're building a television set—their poor quality shows up in the reproduced images the first time you turn the outfit on. The eye is more critical than the ear, and you just can't get away with distortion. Use cheap parts and the pictures will look like scrambled eggs in a hot

pan; use Pilot parts and they'll stand out nice and clear.

Pilot parts are made in the world's largest radio parts plant, and are backed by twenty-three years of manufacturing experience. They are uniform and dependable, and are suitable for every television requirement.

### I. F. Transformers

How about building a super-hot and getting really decent signals from those weak stations? Use the No. 241 I.F. transformers. Packed three to a box and accurately matched to 175 kc. Latest design and construction, fully shielded by aluminum cans.

List Price: (kit of 3) \$5.00



No. 241

### A. C. Power Pack

The K-139 is a man-sized pack, factory built. Enough juice for the neon tube and the receiver both. D.C. output 125 ma., 300 volts; A.C. output. 6 amps. at 4 volts; 12 amps. at 2½ volts; 3½ amps. at 2½ volts; 2 amps. at 5 volts. Uses 280 rectifier. Strong steel construction.

List Price: \$35.50

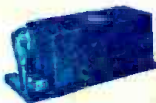

K-139

### Variable Condenser

At last a husky four-gang variable that won't wobble or change in adjustment. Modified SLF curve, 320 mmf. maximum per section. Fine for three stage TRF television tuners or superhets. Size: 4½" x 3¾", 6" long; ¼" shaft. Fully shielded, with individual trimmers.

List Price: \$7.45

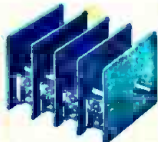

No. 3160

The Pilot line of parts in the only really complete line, embracing everything from knobs to power packs. You can start with it and finish with it. The items described on the right and left are only a few of the collection, selected because they are suited for particular television needs. The entire line is described in the new Pilot catalog, a copy of which is free for the asking. Your name and address on a post card (or your QSL card) will bring you one. Dealers throughout the country handle Pilot parts; if your local man doesn't, send us his name and address when you write for your catalog.

### Variable Resistor

A variable "jumpless" resistor of the compression type. Range from 40 ohms to 10 megohms through four turns of the knob. Ribbed case, capacity 20 watts. Fine for regulating motor speed or neon lamp exciting current. Single hole mounting; size 2½" x 1½".

List Price: \$.75



No. 350

### Resistance Coupling Unit

Absolutely indispensable for television audio amplifiers. Molded bakelite base, with depression for any Pilot Isograd fixed condenser and clips for resistors. Practically any combination of capacity and resistance is possible. The handiest experimental A.F. unit on the market.

List Price: \$.40



No. 501

### By-Pass Condenser

Non-inductive by-pass condenser, three sections of .2 mf. each, in common case. Flexible leads. Flash tested at 1250 volts, rated at 300 volts working. Essential for proper by-passing in cathode, screen and plate circuits, to prevent coupling and feedback. List Price: \$1.05



No. 806

## Pilot Radio & Tube Corporation

Factory and Main Office: LAWRENCE, MASS., U.S.A.

Branch Offices: 525 Broadway, New York; 234 So. Wells St., Chicago; 1278 Mission St., San Francisco.

Other offices in the principal Cities of the World